

## TRAINING MANUAL

# MODEL 465M OZONE MONITOR



**TELEDYNE  
INSTRUMENTS**  
*Advanced Pollution Instrumentation*  
A Teledyne Technologies Company

© **TELEDYNE ADVANCED POLLUTION INSTRUMENTATION  
(T-API)**  
**9480 CARROLL PARK DRIVE  
SAN DIEGO, CA 92121-5201**

**TOLL-FREE: 800-324-5190**  
**TEL: 858-657-9800**  
**FAX: 858-657-9816**  
**E-MAIL: [api-customerservice@teledyne.com](mailto:api-customerservice@teledyne.com)**  
**WEB SITE: [www.teledyne-api.com](http://www.teledyne-api.com)**



# **TABLE OF CONTENTS**

---

- 1. PRINCIPLE OF OPERATION**
- 2. PNEUMATICS AND ASSEMBLIES**
- 3. LAYOUT**
- 4. MENU STRUCTURE**
- 5. CALIBRATION PROCEDURES**
- 6. MAINTENANCE**
- 7. TROUBLESHOOTING & FAULTS**
- 8. SPECIFICATIONS**
- 9. SCHEMATICS**
- 10. SERVICE NOTES**



# **1. PRINCIPLE OF OPERATION**

---



## 1.1. THEORY OF OPERATION

The detection of ozone molecules is based on absorption of 254 nm UV light due to an internal electronic resonance of the O<sub>3</sub> molecule. The Model 465 uses a mercury lamp constructed so that a large majority of the light emitted is at the 254nm wavelength. Light from the lamp shines down a hollow quartz tube that is alternately filled with sample gas, and then filled with gas scrubbed to remove ozone. The ratio of the intensity of light passing through the scrubbed gas to that of the sample forms a ratio I/I<sub>o</sub>. This ratio forms the basis for the calculation of the ozone concentration.

The Beer-Lambert equation, shown below, calculates the concentration of ozone from the ratio of light intensities.

$$C_{O_3} = -\frac{10^9}{\alpha \times \ell} \times \frac{T}{273^\circ \text{K}} \times \frac{29.92 \text{inHg}}{P} \times \ln \frac{I}{I_o}$$

Where:

- I = Intensity of light passed through the sample
- I<sub>o</sub> = Intensity of light through sample free of ozone
- α = absorption coefficient
- ℓ = path length
- C<sub>O<sub>3</sub></sub> = concentration of ozone in ppb
- T = sample temperature in degrees Kelvin
- P = pressure in inches of mercury

As can be seen the concentration of ozone depends on more than the intensity ratio. Temperature and pressure influence the density of the sample. The density changes the number of ozone molecules in the absorption tube which impacts the amount of light removed from the light beam. These effects are addressed by directly measuring temperature and pressure and including their actual values in the calculation. The absorption coefficient is a number that reflects the inherent ability of ozone to absorb 254 nm light. Most current measurements place this value at 308 cm<sup>-1</sup> atm<sup>-1</sup> at STP. The value of this number reflects the fact that ozone is a very efficient absorber of UV radiation which is why stratospheric ozone protects the life forms lower in the atmosphere from the harmful effects from solar UV radiation. Lastly, the absorption path length determines how many molecules are present in the column of gas in the absorption tube.

The intensity of light is converted into a voltage by a high resolution A/D (analog-to-digital) converter. The digitized signal and other variables are used by the CPU to compute the concentration using the above formula.

About every 2.5 seconds the M465 completes a measurement cycle consisting of a 1 second wait period for the sample tube to flush, followed by a 150 ms measurement of the UV light intensity to obtain (I). The sample valve is switched to admit scrubbed sample gas for 1 second, followed by a 150 ms measurement of the UV light intensity to obtain (I<sub>0</sub>). Measurement of the (I<sub>0</sub>) every 2.5 seconds eliminates instrument drift due to changing intensity of the lamp caused by aging and dirt.



## **2. PNEUMATIC AND ASSEMBLIES**

---



## 2.1. PNEUMATIC DIAGRAM

Figure 1 and Figure 2-2 below is a pneumatic diagram that can be referenced when performing troubleshooting on the monitor.

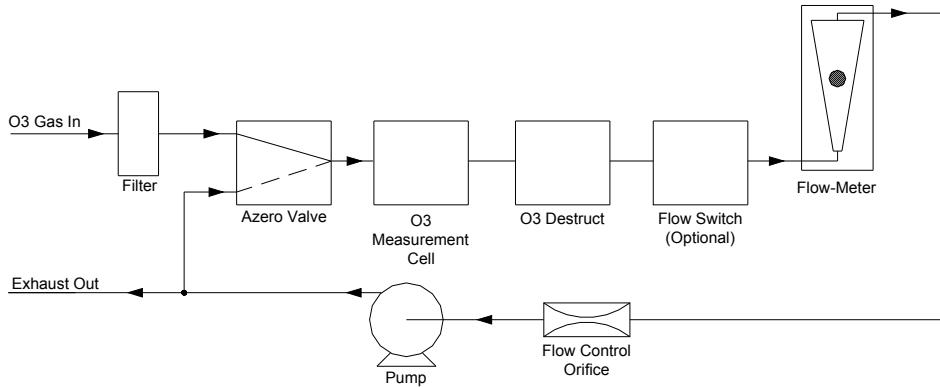

Figure 2-1: Pneumatic Diagram (Rack Mount Version)

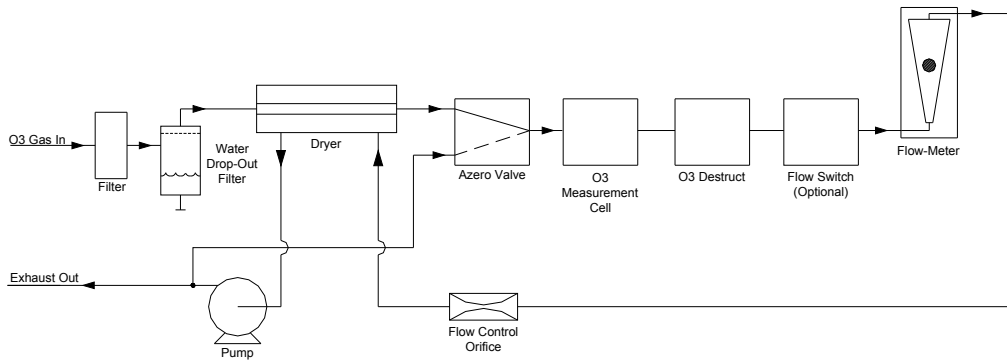

Figure 2-2: Pneumatic Diagram (NEMA Version with Sample Conditioner)

## 2.2. PNEUMATIC CONNECTIONS

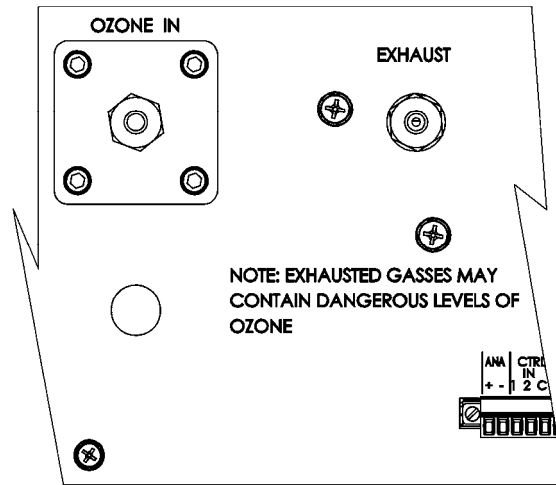

Figure 2-3: Pneumatic Connections, Rack Mount Configuration

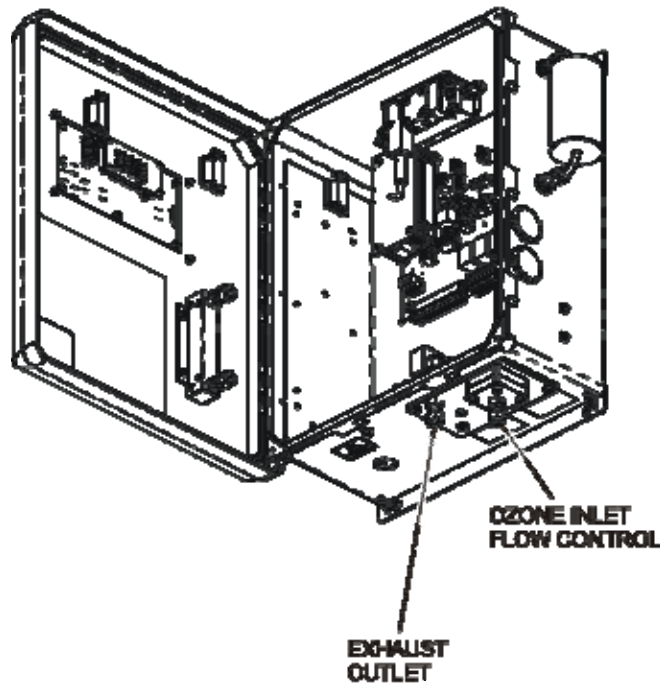

Figure 2-4: Pneumatic Connections, NEMA Configuration

## **3. INSTRUMENT LAYOUT**

---

## M465M OZONE MONITOR

### 3.1. INSTRUMENT LAYOUT

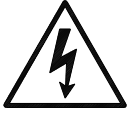

**Error! Reference source not found.** and **Error! Reference source not found.** shows the internal layout of the M465M. These figures will be referenced in the procedures that follow.

Note the caution areas where high voltage (line voltage) may be present when power is connected to the instrument.

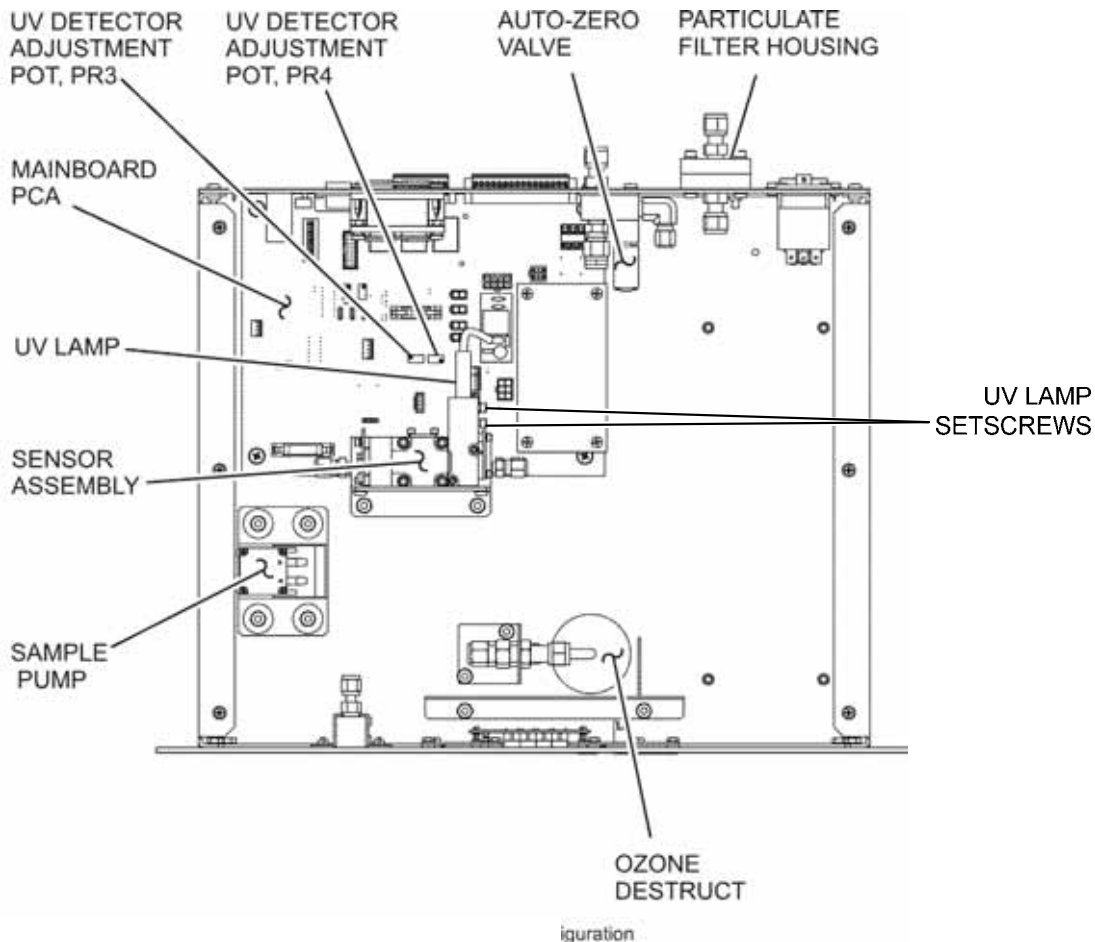
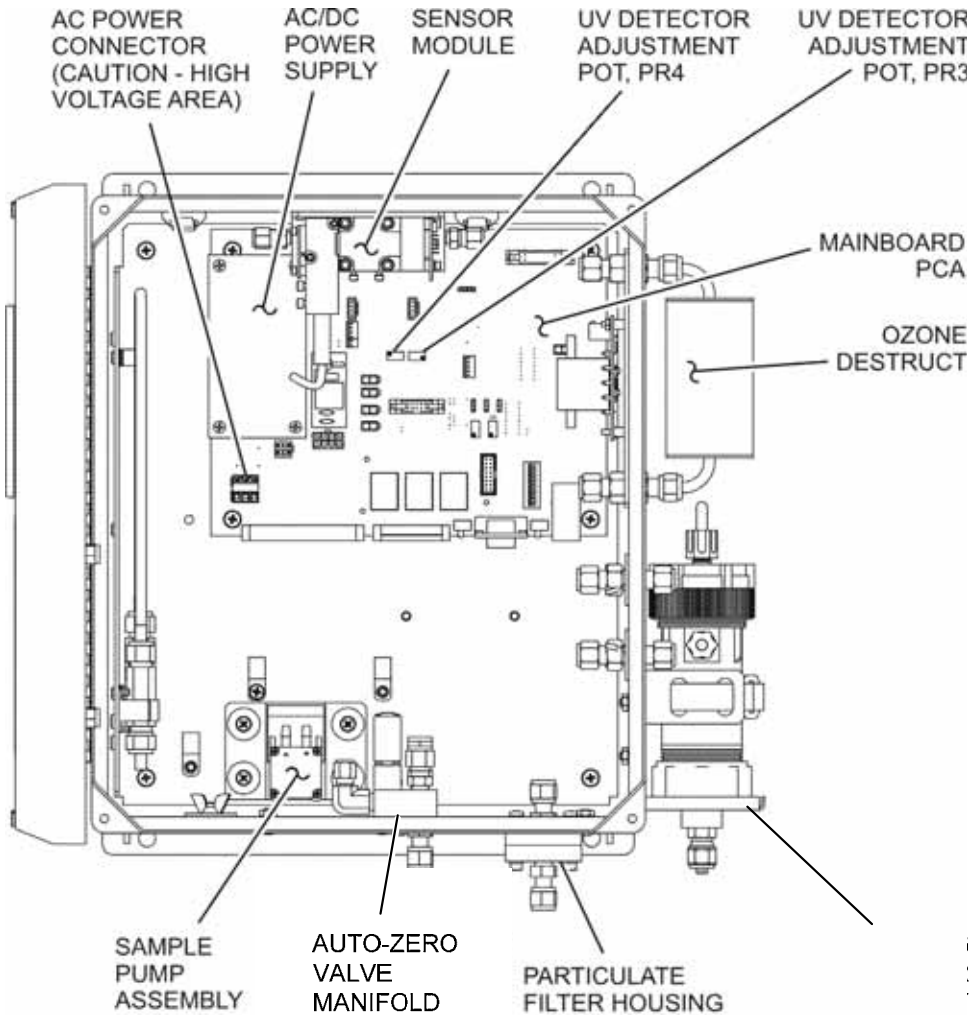

Figure 3-1: Instrument Layout, Rack Mount Configuration



Juration

Figure 3-2: Instrument Layout, NEMA Configuration





## **4. MENU STRUCTURE**

---



## 4.1. FRONT PANEL MENU STRUCTURE

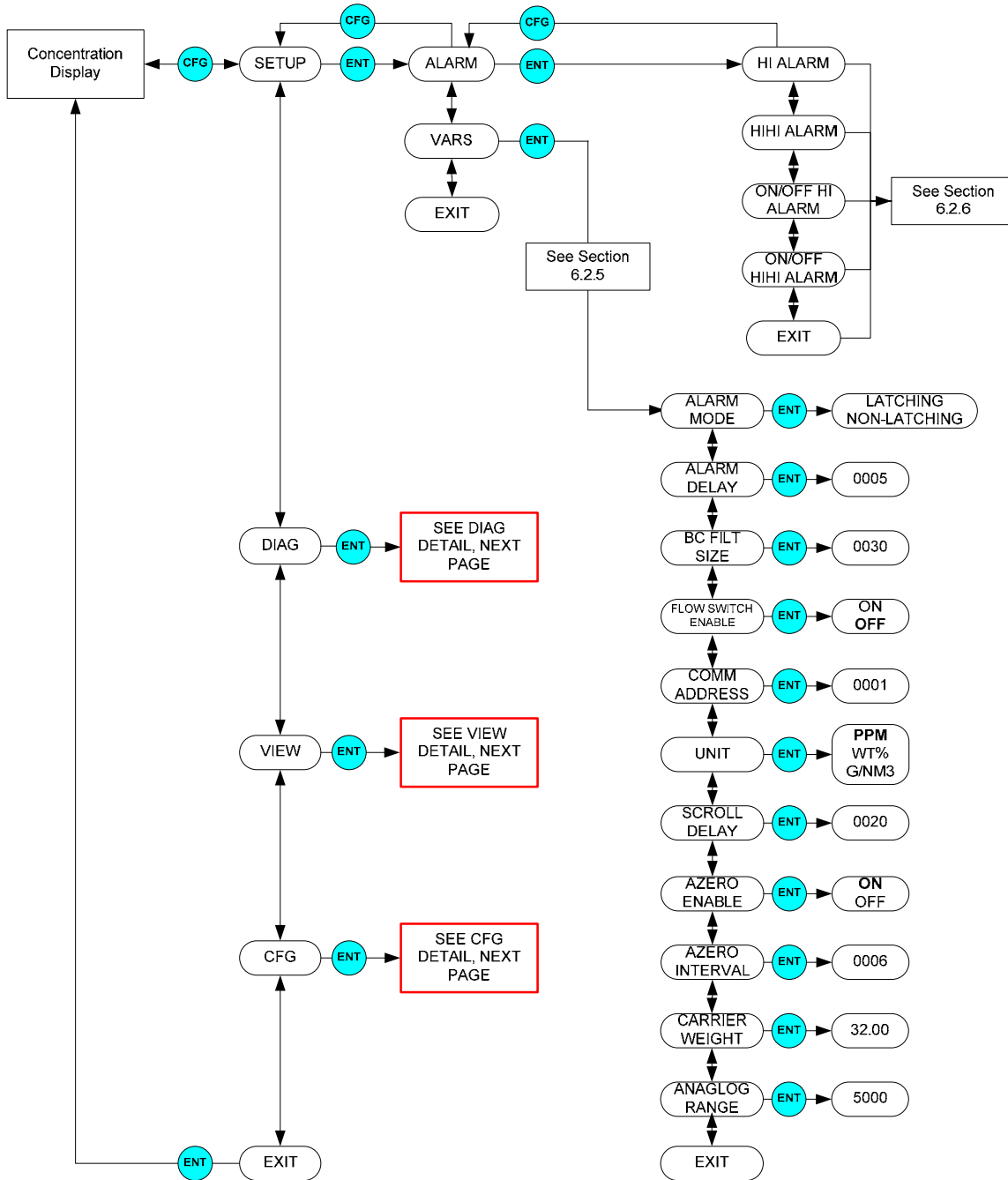

M465M-Front Panel Menu Diagram, Rack Mount

Figure 4-1: Front Panel Menu Diagram (Page 1)

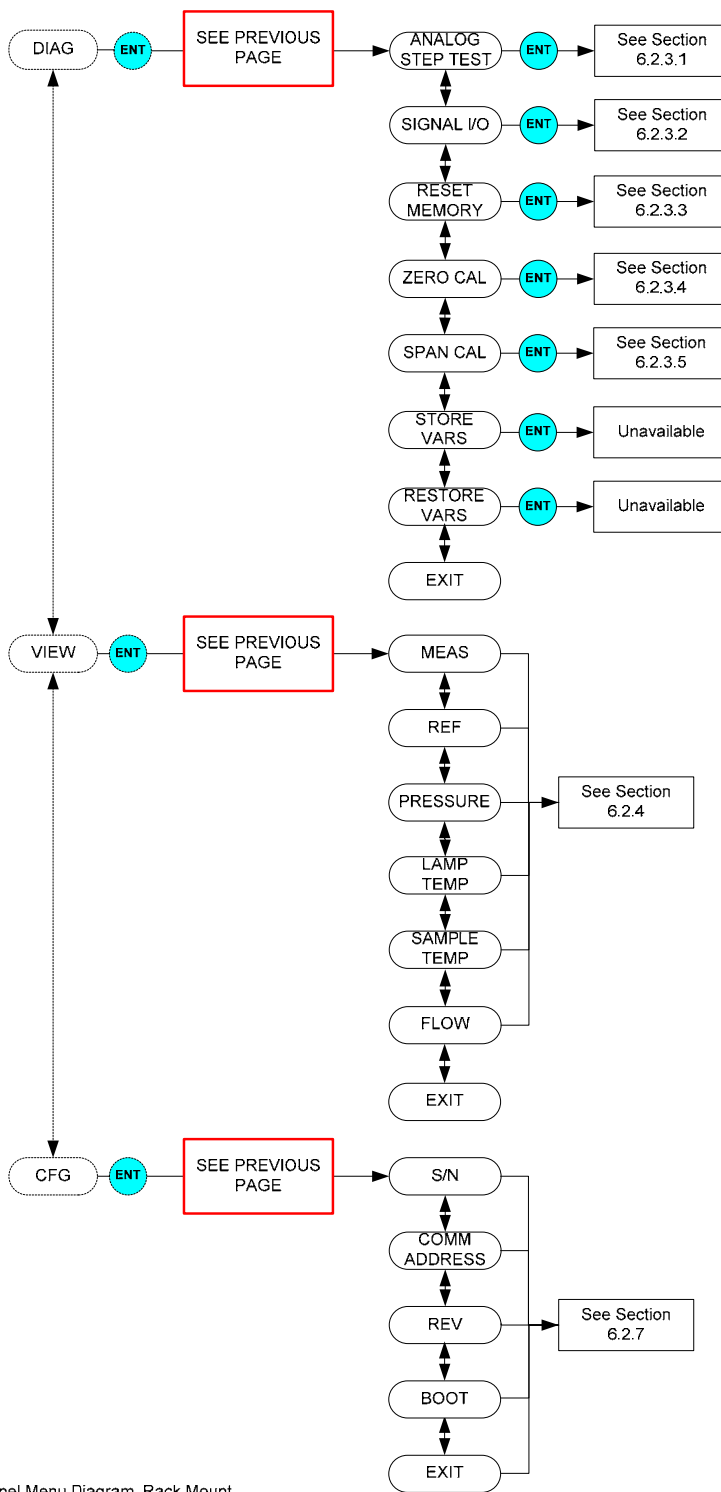

M465M-Front Panel Menu Diagram, Rack Mount

**Figure 4-2: Front Panel Menu Diagram (Page 2)**

## **5. CALIBRATION PROCEDURES**

---

## **5.1. FACTORY CALIBRATION**

The M465M is calibrated to internal T-API calibration standards to shipment. A calibration certificate for your instrument can be purchased from Teledyne API if required. Teledyne API also recommends that the M465M be re-calibrated once a year. Teledyne API can provide NIST traceable calibration services at our factory or on-site. Please contact our Customer Service department for details on these services.

## **5.2. ZERO CALIBRATION**

The zero calibration allows the instrument to calibrate its internal ozone offset factor. This should only be done with a source of zero air connected to the “Sample In” port of the M465M. Allow the instrument to stabilize on the zero air source before attempting to zero. This normally takes 10-15 minutes.

If the zero calibration is enabled, the internal ozone offset factor will automatically be reported as zero every 6 minutes. If the zero calibration is disabled, then manual calibration is necessary based on the customer’s applications. For normal applications, the zero calibration is not necessary.

When entering the Zero Calibration menu, the prompt “ENT TO CAL” appears on the display. Simply confirm the calibration by pressing the **ENT** button to perform the calibration (to abort the calibration, press and hold the **CFG** button to return to the previous menu level.) After pressing **ENT**, the instrument will automatically exit the menu mode and return to Concentration mode. The concentration reading should quickly go to zero.

### **NOTE**

While measuring zero air, a certain amount of noise or “dithering” of the concentration about the zero point will occur and is normal. This noise is typically 1-3 PPM in magnitude.

## **5.3. SPAN CALIBRATION**

The Span Calibration also allows the instrument to calibrate its internal ozone offset factor. The Span Calibration however, is done with some controlled concentration gas connected to the “Sample In” port of the M465M. It is recommended that a span gas is concentrated to around 80% of the operating range. Set the SPAN VALUE to the measured concentration of your calibration gas. This normally takes 10-15 minutes.

**NOTE**

A Span Calibration should only be performed with a precision source of ozone calibration gas, such as a Teledyne API Model 700 or Model 703 calibrator. Simple ozone generators without a measurement feedback system should never be used for performing span calibrations.

If you are unsure regarding the suitability of a particular source of calibration gas, contact Customer Service at Teledyne API for assistance.

See **Error! Reference source not found.**5-1 shows the Span Cal menu. After the instrument has stabilized on the source of span gas, navigate to the Span Cal menu (See **Error! Reference source not found.**1) and Press **ENT**. Next enter the Span Target concentration (the actual concentration of ozone being supplied to the monitor) and press **ENT**. The display will next show a confirmation menu, **ENT TO SPAN**. Press **ENT** to perform the Span Calibration, or **CFG** to abort back to the start. If the calibration is successful, the display will return to the concentration menu and the monitor reading should change adjust to read very close to the target value. If the calibration cannot be performed, an **OUT OF RANGE** error will be displayed. Press **ENT** to confirm and the display will return to the start of the Span Cal menu.

If the **OUT OF RANGE** error occurs, it means the Span Cal cannot be performed because it would result in an out of range slope value for the monitor. This means that either the sensor in the monitor is malfunctioning, causing improper readings, or the actual ozone concentration being supplied to the monitor is different than the target value being entered.

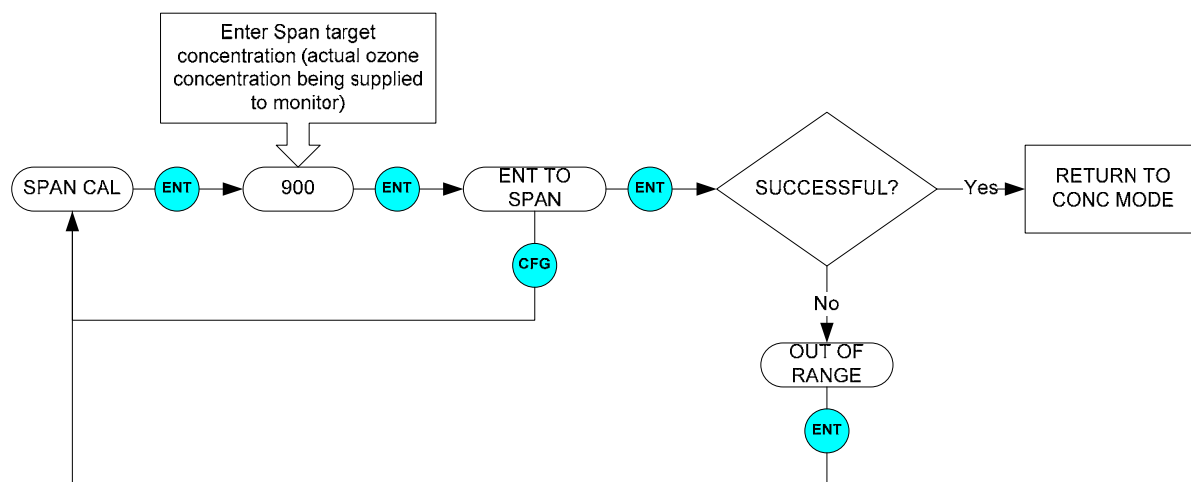

**Figure 5-1: Span Cal Menu**

## 5.4. Analog Output Calibration

### 5.4.1 Configuring the Analog Output

The analog output can be configured for either 0-5V DC or 4-20mA operation. To change or verify the configuration of the analog output:

1. Disconnect power from the M465M.
2. Remove the six screws and the top cover (Rack Mount Configuration) or open front panel (NEMA Configuration.)
3. Locate the Main board PCA (see **Error! Reference source not found.** or **Error! Reference source not found.**)
4. Set the desired operation as shown in Figure 5-5-2.
5. Re-Install the top cover or re-secure the front panel (NEMA Configuration.)

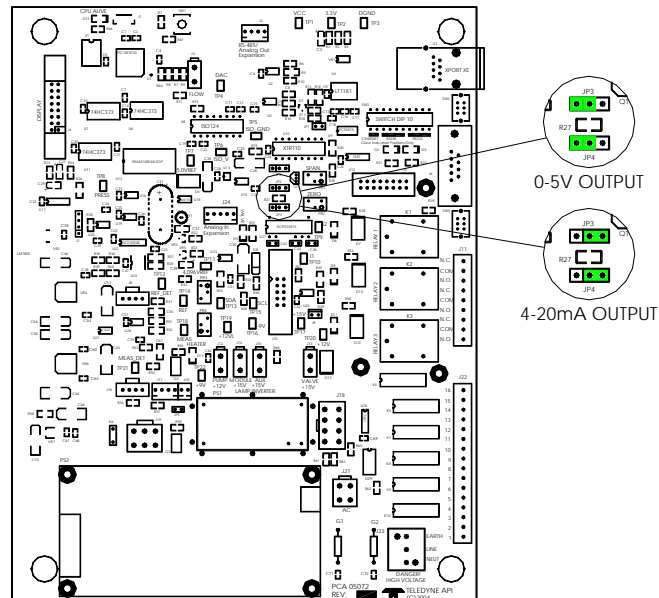
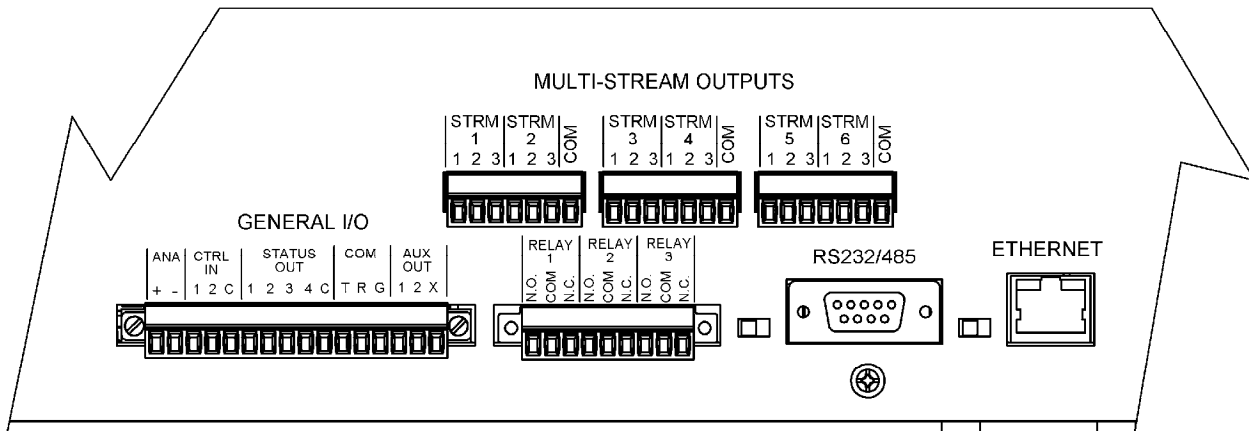

Figure 5-2: Main board – Analog Output Configuration

### 5.4.2 CURRENT CALIBRATION

1. Ensure that the jumpers on the board are set to current. Refer to FIGURE 5-2
2. Disconnect the GENERAL I/O connector located on the rear panel of the instrument. Refer to 5-3.





**Figure 5-3: REAR PANEL ELECTRICAL I/O CONNECTIONS**

3. Insert meter probes into ANA +/- . Set the Meter for DC current. Ensure that the meter leads are setup on the meter for DC current.
4. On the front panel display press CFG-▼-ENT. You are now in the ANALOG STEP TEST. (This will step from 0% to 100% of your output range) Press ENT.
5. Press ▼ to stop the step test at 0%.
6. Turn the ZERO potentiometer on the board Counter Clockwise (CCW) until the meter reads 4ma.
7. Press ▼ again once to step down to 100%.
8. Turn the SPAN potentiometer on the board (CCW) until the meter reads 20ma.
9. You will need to do this a few times as the both ZERO/SPAN potentiometers will affect one another.



## **6. MAINTENANCE AND ADJUSTMENTS**

---

## 6.1. MAINTENANCE TABLE

Table 6-6-1 below outlines the suggested maintenance procedures and intervals for ensuring the M465M continues to operate accurately and reliably. These intervals are based on continuous (24 hours a day – 7 days a week) operation. These intervals may be lengthened for intermittent operation.

**Table 6-1: Maintenance Schedule**

Maintenance Item	Recommended Interval	Section
Replace particulate filter element	6 months <sup>*1</sup>	6.22
Adjust UV lamp	As Indicated by 'Check Lamp' LED or status output	6.33
Replace lamp	As required; when adjustment can no longer be performed.	6.4
Replace sample pump	2 years	6.5
Replace Auto-Zero Valve	2 years	6.6
Rebuild cells, replace o-rings	3 years	Return to factory
*1 When external sample line pre-filters are used. If pre-filters are not used, internal sample filter should be replaced every month.		

## 6.2. Replacing Internal Particulate Filter

1. Disconnect power from the M465M.
2. Loosen the six screws from the top cover (Rack Mount Configuration, see **Error! Reference source not found.**) or open front panel (NEMA Configuration, see **Error! Reference source not found.**)
3. Remove the six screws and top cover from the instrument.
4. Locate the particulate housing filter on the rear panel (Rack Mount Configuration, see **Error! Reference source not found.**) or the bottom panel (NEMA Configuration, see **Error! Reference source not found.**)
5. Loosen the four screws on the sample filter body (see Figure 6-6-1.)
6. Remove the four screws, the four washers and the sample filter body from the sample filter base.
7. Remove the o-ring and inspect for any cracks or deformities. If there are no cracks or deformities, place the o-ring back in the sample filter body.

**NOTE**

If the o-ring is cracked or deformed, discard the o-ring and replace with a new one.

8. Remove the two sample filter retainers and glass fiber filter element from the sample filter body.
9. Discard the glass fiber filter element.
10. Place a new glass fiber filter element in between the two sample filter retainers and place in the sample filter body.
11. Place the sample filter body on the sample body base and secure with the four screws and four washers.
12. Reinstall the top cover on the instrument and secure with the six screws or close the front panel.

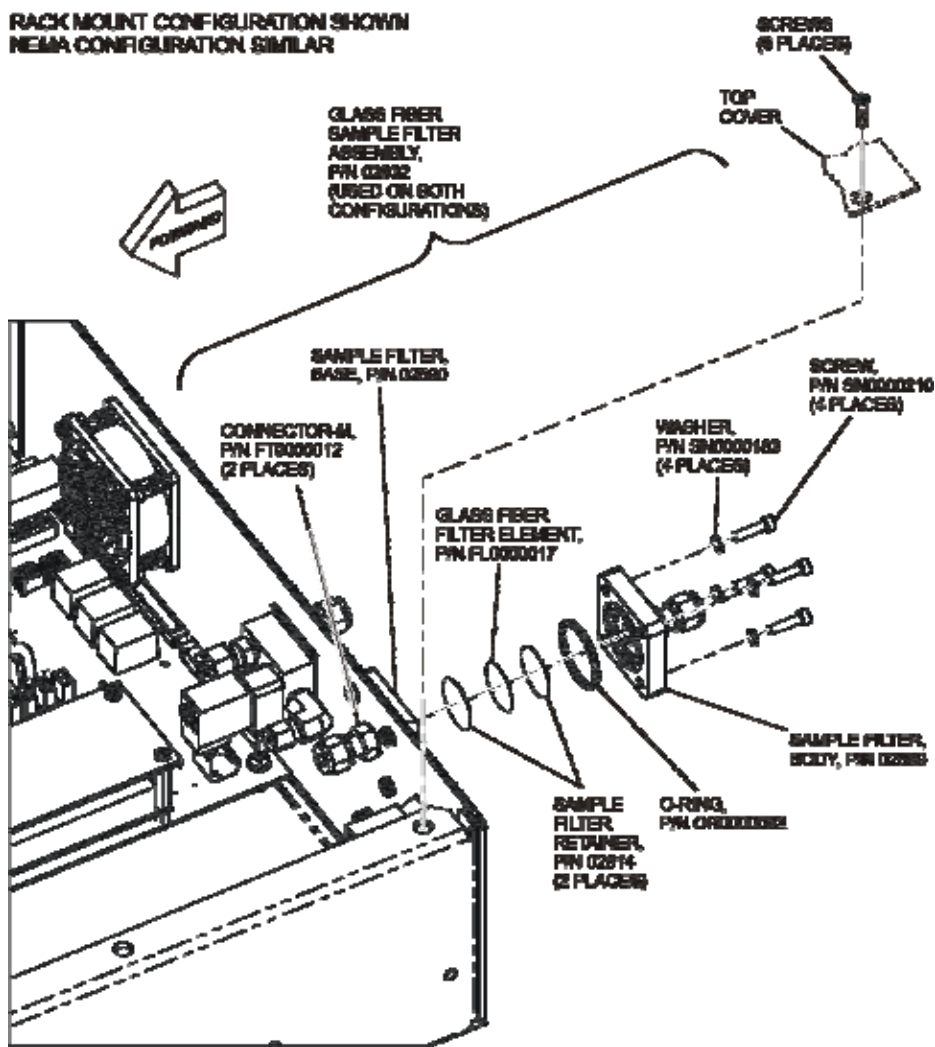

Figure 6-1: Internal Particulate Filter Replacement

## 6.3. UV Lamp Adjustment



1. Instrument should be running and warmed up for at least 20 minutes.
2. With instrument running, remove the six screws and the top cover (Rack Mount Configuration) or open front panel (NEMA Configuration.)
3. Locate the Reference UV Detector adjustment pot, PR3, on the Mainboard PCA (see **Error! Reference source not found.** or **Error! Reference source not found.**)
4. Navigate the front panel menu to VIEW menu and scroll to REF display and press **ENT**. At this point there should be a scrolling display similar to “REF = XXXX MV.” See Section 4.1 for details on menu navigation.
5. While observing the REF value on the display, slowly turn the pot to adjust the value. The target adjustment range is as high as possible within the range of **800 – 1150 mV**.
6. Locate the Measure UV Detector adjustment pot, PR4, on the mainboard PCA (see **Error! Reference source not found.** or **Error! Reference source not found.**)
7. Navigate the front panel menu to VIEW menu and scroll to MEAS display and press **ENT**. At this point there should be a scrolling display similar to “MEAS = XXXX MV.” See Section 4.1 for details on menu navigation.
8. While observing the MEAS value on the display, slowly turn the pot to adjust the value. The target adjustment range is as high as possible within the range of **800 – 1150 mV**.
9. If the required adjustment cannot be achieved by adjusting the UV Detector pot alone, then additional adjustment can be made by loosening the two UV lamp setscrews on the UV lamp housing (see **Error! Reference source not found.** or **Error! Reference source not found.**) and rotating the lamp. Rotate the lamp very slowly while observing the REF or MEAS value on the display. Make sure the lamp does not pull out and remains seated in the housing while it is being rotated. Re-tighten the two setscrews when a desired point has been reached.
10. If necessary, additional “fine tuning” can now be done with the UV Detector adjustment pots per steps 4-8.
11. Re-Install instrument cover and observe REF and MEAS values on display for a couple minutes to verify it does not drift out of the adjustment range.

## 6.4. UV Lamp Replacement



1. Disconnect power from the M465M.
2. Remove the six screws and the top cover (Rack Mount Configuration) or open front panel (NEMA Configuration.)
3. Loosen the two UV lamp setscrews on the UV lamp housing (see **Error! Reference source not found.3-1** or **Error! Reference source not found.3-2.**)
4. Unplug the lamp power cord from the connector labeled J18 on the mainboard PCA.
5. Carefully slide the lamp out of housing.
6. Install the new lamp, seating it in the lamp housing until it stops.

7. Re-tighten the two UV lamp setscrews.
8. Plug the lamp power cord into J18 on the mainboard PCA.
9. Reconnect power to the instrument and turn on power switch. Let instrument warm up for at least 20 minutes.
10. Perform UV lamp adjustment procedure per Section 6.3.

## **6.5. Sample Pump Replacement**

1. Disconnect power from the M465M.
2. Remove the six screws and the top cover (Rack Mount Configuration) or open front panel (NEMA Configuration.)
3. Locate sample pump assembly (See **Error! Reference source not found.3-1** or **Error! Reference source not found.3-2**.)
4. Cut off the clamps holding the Tygon tubing to the pump nipples and remove tubing. Note which tubing is connected to inlet and outlet.
5. Unplug the pump power connector from the mainboard PCA at connector J12.
6. Remove the four screws attaching the sample pump assembly to the chassis.
7. Turn over pump assembly and remove the two screws holding the sheet-metal base to the pump.
8. Install the base on the new pump.
9. Install new pump assembly in chassis.
10. Cut off the ends of the used Tygon tubing and reconnect tubing; note that outlet fitting of pump should be connected to tubing routed to the 'Exhaust' fitting on rear panel.
11. Re-install new tubing clamps or cable-ties to secure tubing connections.

## **6.6. Auto Zero Valve Replacement**

1. Disconnect power from the M465M.
2. Remove the six screws and the top cover (Rack Mount Configuration) or open front panel (NEMA Configuration.)
3. Locate the auto-zero valve (See **Error! Reference source not found.3-1** or **Error! Reference source not found.3-2**.)
4. Unplug the two-pin valve connector from the mainboard PCA.
5. Remove the silver retainer clip from the top of the sensor valve. A pair of pliers may be used to slide off the retainer clip.
6. The valve coil can now be removed by sliding upwards.

7. Remove the two (2) mounting screws using a #2 Phillips screwdriver. Note that there are four screw heads visible on the top of the valve body, only two (2) of these should be removed. Use the new valve as a reference to determine which two screws need to be removed.
8. Note the orientation of the valve body on the manifold so that the new valve can be installed in the same orientation.
9. Remove valve body from sensor manifold.
10. Clean any residue or dirt off the surface of the manifold using a lint-free cloth and distilled or DI water.
11. Install the new valve by reversing steps 1-7.





## **6.7. Cleaning Exterior Surfaces of the M465M**

If necessary, the front panel mask and keyboard of the M465M can be cleaned with a damp cloth. Do not attempt to clean any of the other surfaces of the instrument. Do not submerge any part of the instrument in water or cleaning solution.



## 7. TROUBLESHOOTING

	<p><b>CAUTION</b> RISK OF ELECTRICAL SHOCK. THE OPERATIONS OUTLINED IN THIS CHAPTER ARE TO BE PERFORMED BY QUALIFIED MAINTENANCE PERSONNEL ONLY!</p>
	

## 7.1. Reference Drawings

The drawings contained in this section are for general reference and may be useful when performing certain troubleshooting activities.

### 7.1.1. Pneumatic Diagram

Figure and Figure below is a pneumatic diagram that can be referenced when performing troubleshooting on the monitor.

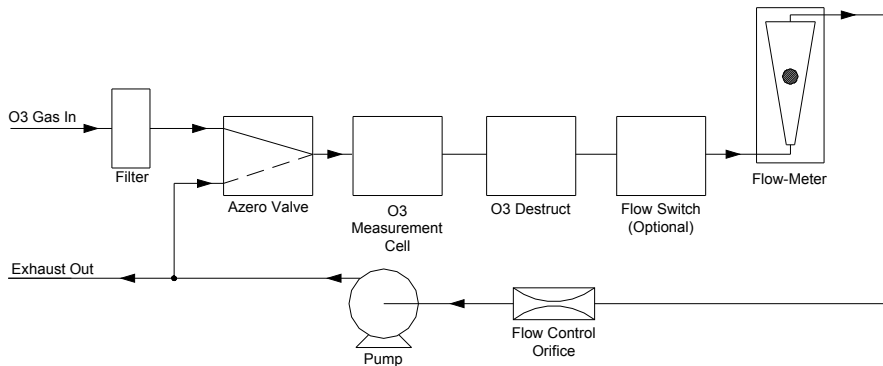

**Figure 7-1: Pneumatic Diagram (Rack Mount Version)**

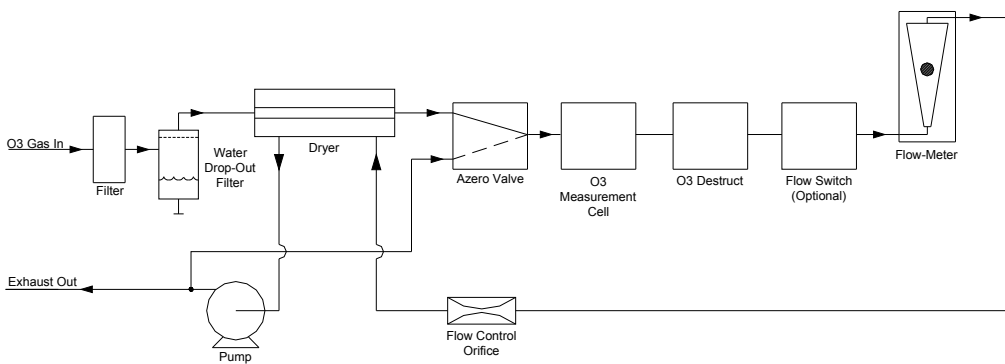

**Figure 7-2: Pneumatic Diagram (NEMA Version with Sample Conditioner)**

### 7.1.2. Interconnect Diagram

Figure 7-3 below details the electrical connections between the various electronic modules in the M465M.

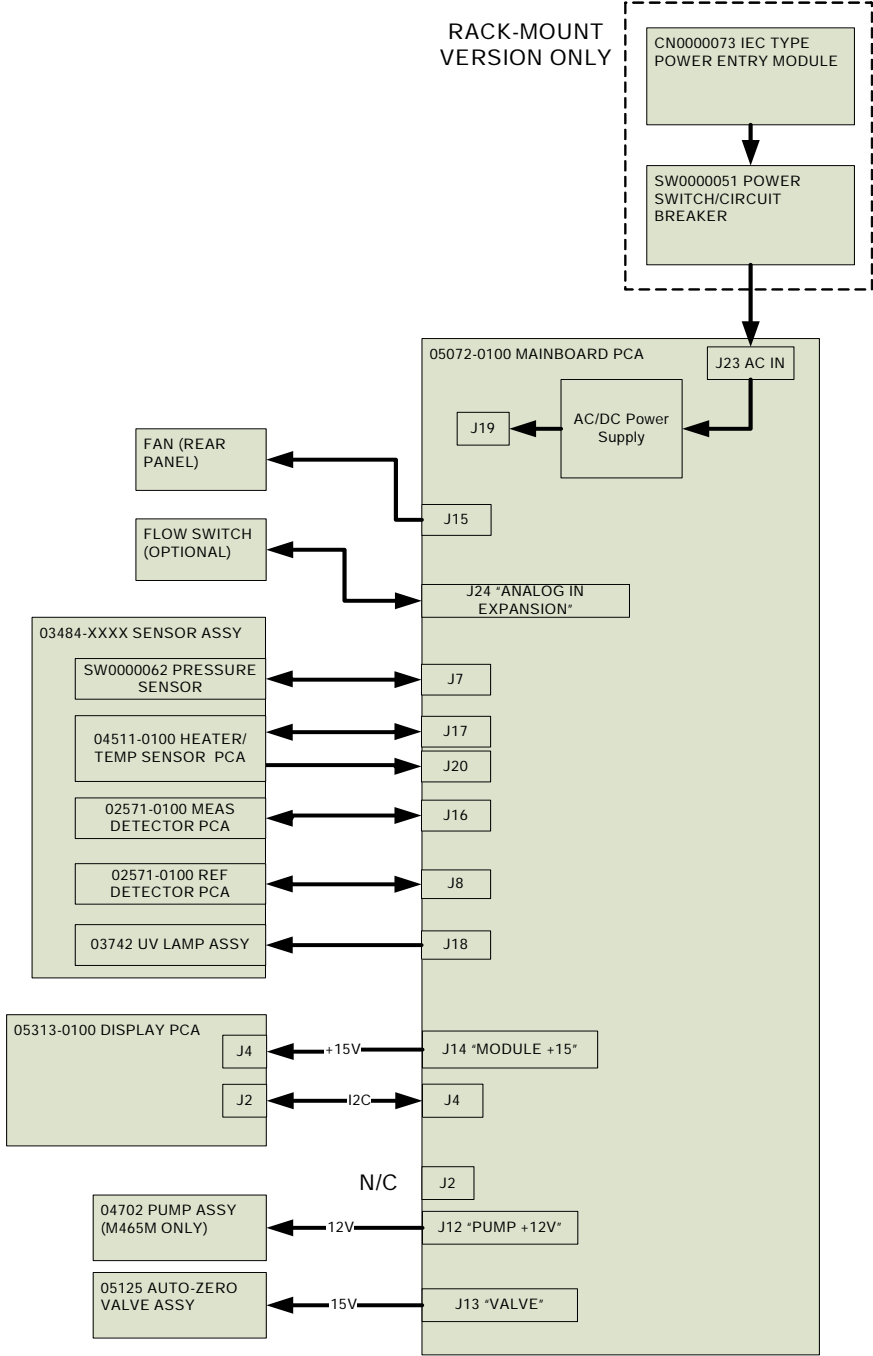
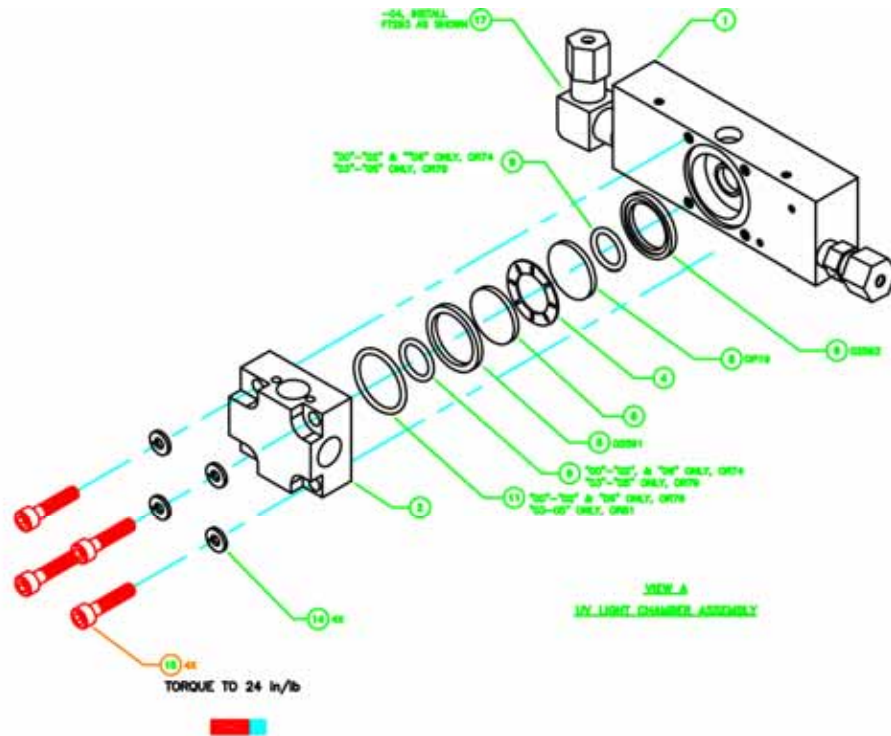
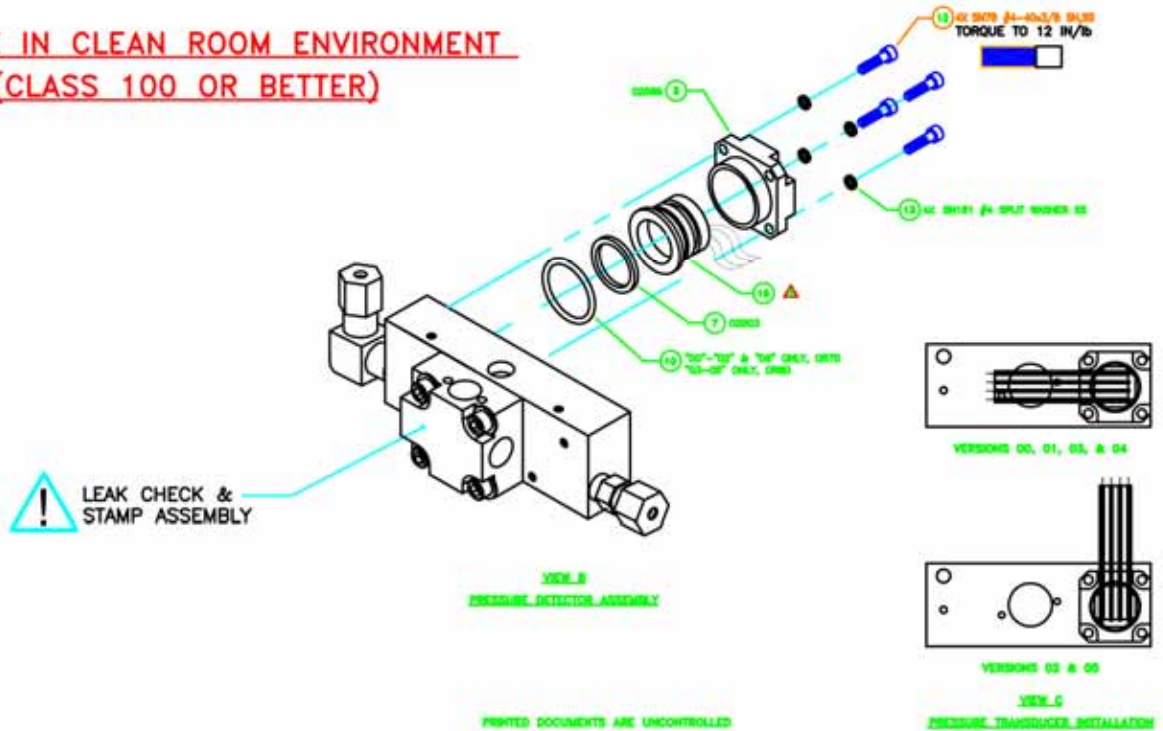

Figure 7-3: Interconnect Diagram

### 7.1.3. Bench Breakdown



**ASSEMBLE IN CLEAN ROOM ENVIRONMENT  
(CLASS 100 OR BETTER)**



## 7.2. Troubleshooting Using Front Panel Status LED's or Status Outputs

The M465M has 4 front-panel status LED's that reflect the current operating status of the monitor, and indicate fault conditions. There are also four relay Status Outputs on the rear panel (or internally in the NEMA configuration) that also reflect the state of these status LED's.

**Table 7-1: Status LED/Output Definitions**

Status Output #	Status LED Label	Normal Operating State	Triggers	Critical Warning?
1	Sensor OK	On	<ul style="list-style-type: none"> <li>• Reference &lt; 125.0 mV</li> <li>• Reference &gt; 1230.0 mV – 0.5 Wt%</li> </ul>	Yes
2	Invalid Reading	Off	<ul style="list-style-type: none"> <li>• O3 Concentration &lt; F.S. Range</li> <li>• O3 Concentration &gt; F.S. Range</li> </ul>	No
3	Check Lamp	Off	<ul style="list-style-type: none"> <li>• Reference &lt; 250.0 mV</li> </ul>	No
4	Pneumatic Error	Off	<ul style="list-style-type: none"> <li>• Pressure &lt; 9.0 psia</li> <li>• Pressure &gt; 18.0 psia</li> <li>• Flow &lt; 500 cc/min*</li> </ul>	No
*If Flow Switch installed				

### 7.2.1. Sensor OK

The Sensor OK LED indicates the status of the O<sub>3</sub> sensor module in the monitor. The normal state of this LED (or Status Output) is On. If this LED remains off after the normal warm-up period, then a failure has occurred and the monitor should be removed from service and repaired.

The most common cause of this warning is a failure of the UV Lamp. A UV Lamp Adjustment (See Section 6-3) should be attempted. If the UV Lamp cannot be adjusted to meet the specified values, then a UV Lamp Replacement should be performed (See Section 6-4)

### 7.2.2. Invalid Reading

The Invalid Reading LED indicates that the instrument is reading a value that cannot be represented properly on the analog output. Since the analog output is limited to 0-5V (or 4-20mA,) it cannot properly represent negative values, or values in excess of the full-scale range.

If the monitor is consistently reading negative values, then a zero calibration should be performed, see Section 5.1.

If the monitor is consistently reading values in excess of the full-scale range, then the range value should be adjusted higher.

### **7.2.3. Check Lamp**

The Check Lamp LED indicates that the UV Lamp intensity has dropped below 250mV, a level where UV Lamp Adjustment (See Section 6.3) should be made at the next convenient opportunity. Note that this is a non-critical warning and immediate service is not required. However if the UV Lamp intensity drops below 125mV, then the Sensor OK LED will also turn off, indicating that the monitor must be immediately serviced or taken off-line.

### **7.2.4. Pneumatic Error**

The Pneumatic Error LED indicates that one of the pneumatic parameters, flow or pressure, has gone outside of normal ranges. Note that this is a non-critical warning and immediate service is not required. However if the Sensor



OK LED turns off then the monitor must be immediately serviced or taken off line.

The first step in troubleshooting a Pneumatic Error is determining which parameter has caused the warning. At the monitor front panel, navigate to the VIEW menu. Examine the Flow and Pressure values and compare them to the limits described in Table 7-1 and take appropriate action as described below.

#### 7.2.4.1. Pressure Too High

The monitor inlet is being pressurized. The monitor inlet should be allowed to sample gas at ambient pressure. Disconnect all sample lines from the monitor and read the pressure again. If the value then drops to within the acceptable range, then one of the sample lines is at elevated pressure.

If the inlet is being pressurized, then the design of the sample system should be reviewed and corrected. Contact Teledyne API customer service for assistance.

#### 7.2.4.2. Pressure Too Low

Something may be restricting the flow through the monitor, causing the sample pump to pull a vacuum on the sensor module. First, unplug the sample pump power plug on the Main board PCA and observe the pressure reading. If the pressure reading is still too low, then likely there is a problem with the pressure sensor on the Sensor Module and the Sensor Module should be replaced. Next reconnect the pump and disconnect all sample lines from the monitor and see if the pressure increases to normal levels. If it does, then the problem is somewhere in the sampling system external to the monitor. If the pressure is still below the limit with the sample lines removed, then there is a restriction in the pneumatics of the monitor upstream of the sensor assembly. The most likely cause is a plugged particulate filter. Disconnect the outlet fitting on the sample filter and observe the pressure. If it returns to normal levels then the restriction is in the particulate filter or inlet manifold assembly (multi-stream configurations only.) Replace particulate filter per Section 6.2.



## **8. SPECIFICATIONS**

---



## Specifications

Measuring principle	UV absorption (Beer Lambert Law)
Ranges	User selectable to any full scale range from: 0-1000 PPM to 0-10,000 PPM 0-5 g/Nm <sup>3</sup> to 0-50 g/Nm <sup>3</sup> 0-1 wt% to 0-5 wt%
Display Range Limits (limited to the 4 digit display)	0-1000 PPM to 0-9999 PPM 0-5 g/Nm <sup>3</sup> to 0-50 g/Nm <sup>3</sup> 0-1 wt% to 0-5 wt%
Measurement Units	PPM, wt%, g/Nm <sup>3</sup>
Accuracy	± 1% of Full Scale
Precision/Repeatability	± 0.5% of Full Scale
Display Resolution	1 PPM, 0.001 wt%, 0.01 g/Nm <sup>3</sup>
Response Time (95%)	<45 seconds to 95%
Compensation	Pressure, Temperature (NTP = 273.15K, 760 mmHg)
Gas Inlet Pressure Range	11.0 – 16.0 psia
Sample Flow Rate	0.8 LPM
Temperature Range	5-45° C
Dimensions (H x W x D)	Rack Mount (3U Panel) - 5.22" (133 mm) x 19.0" (483 mm) x 15.3" (388 mm) NEMA 4X – 16.01" (407 mm) x 15.77" (401 mm) x 8.02" (204 mm)
Weight	Rack Mount – 13.6 lbs (6.17 kg) NEMA 4X – 16.5 lbs (7.5 kg)
Power	100-240 V~, 50/60 Hz, 74 W Max
Maximum Operating Altitude	2000 meters
Analog Output	0 – 5 V or 4-20 mA isolated output
Status Outputs	System OK, Invalid Reading, UV Lamp Fault, Pneumatic Error
RS-232 (optional RS-485)	57.6 Kbaud, DB-9 connector
Approvals	CE
Degree of Protection (NEMA version only)	IP65 (NEMA 4x)



## **9. SCHEMATICS**

---





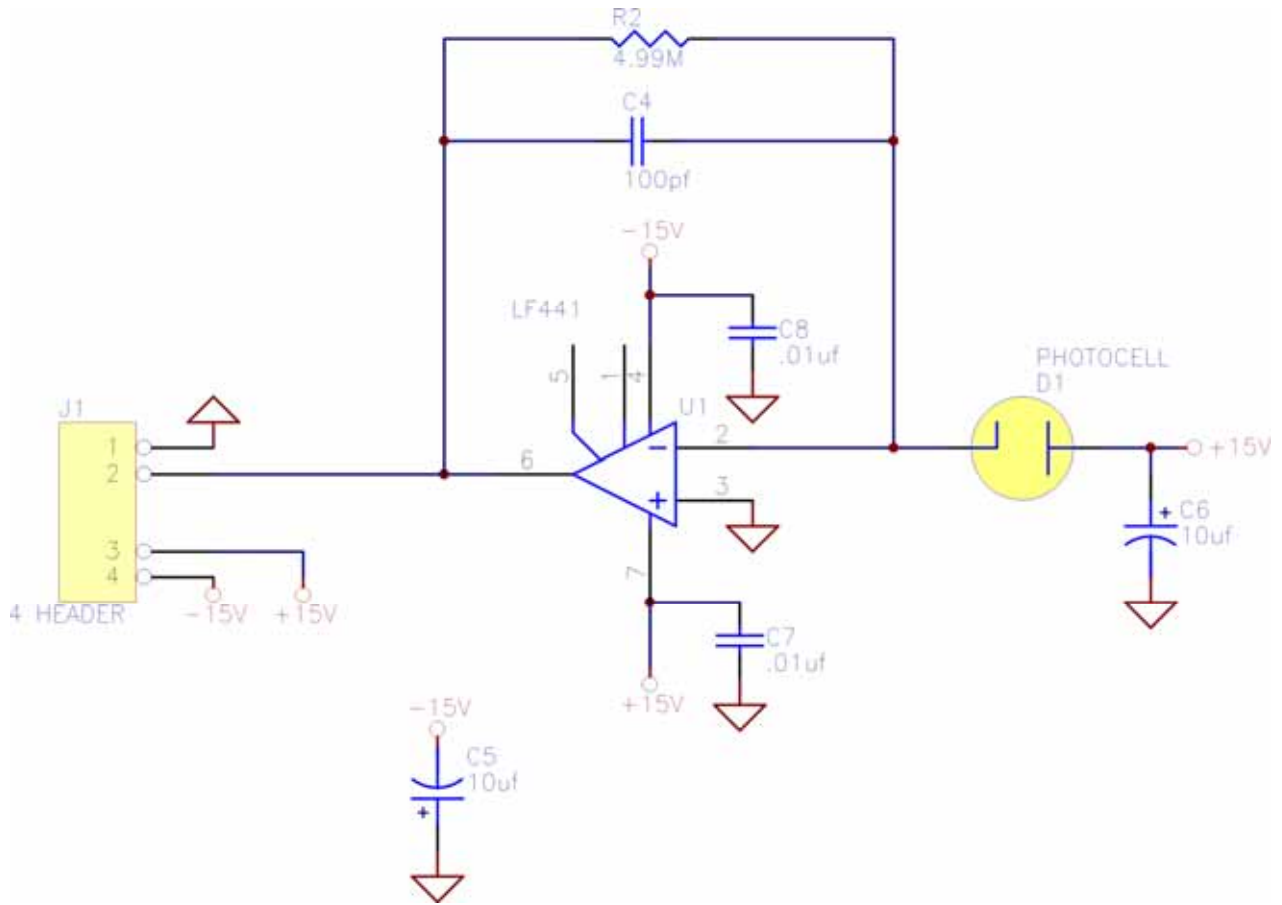

**UV Preamp Schematic**

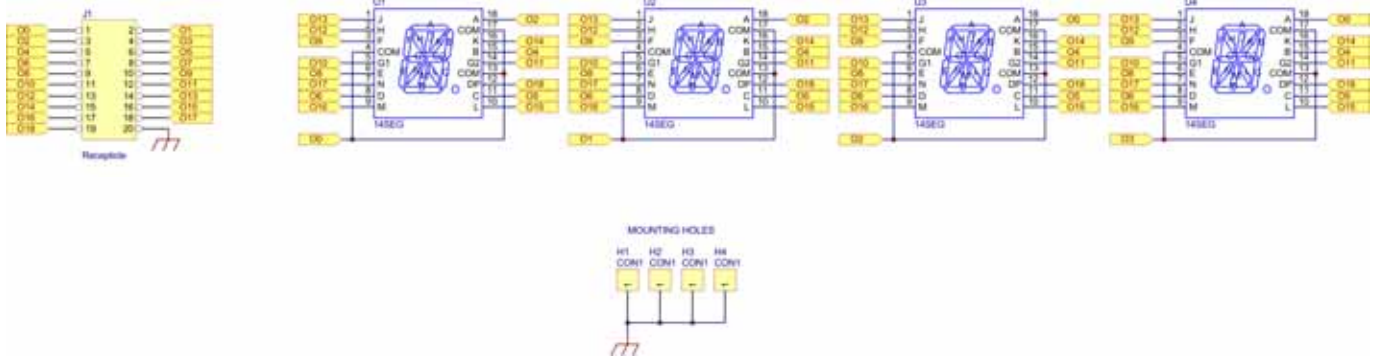

**Display Schematic**

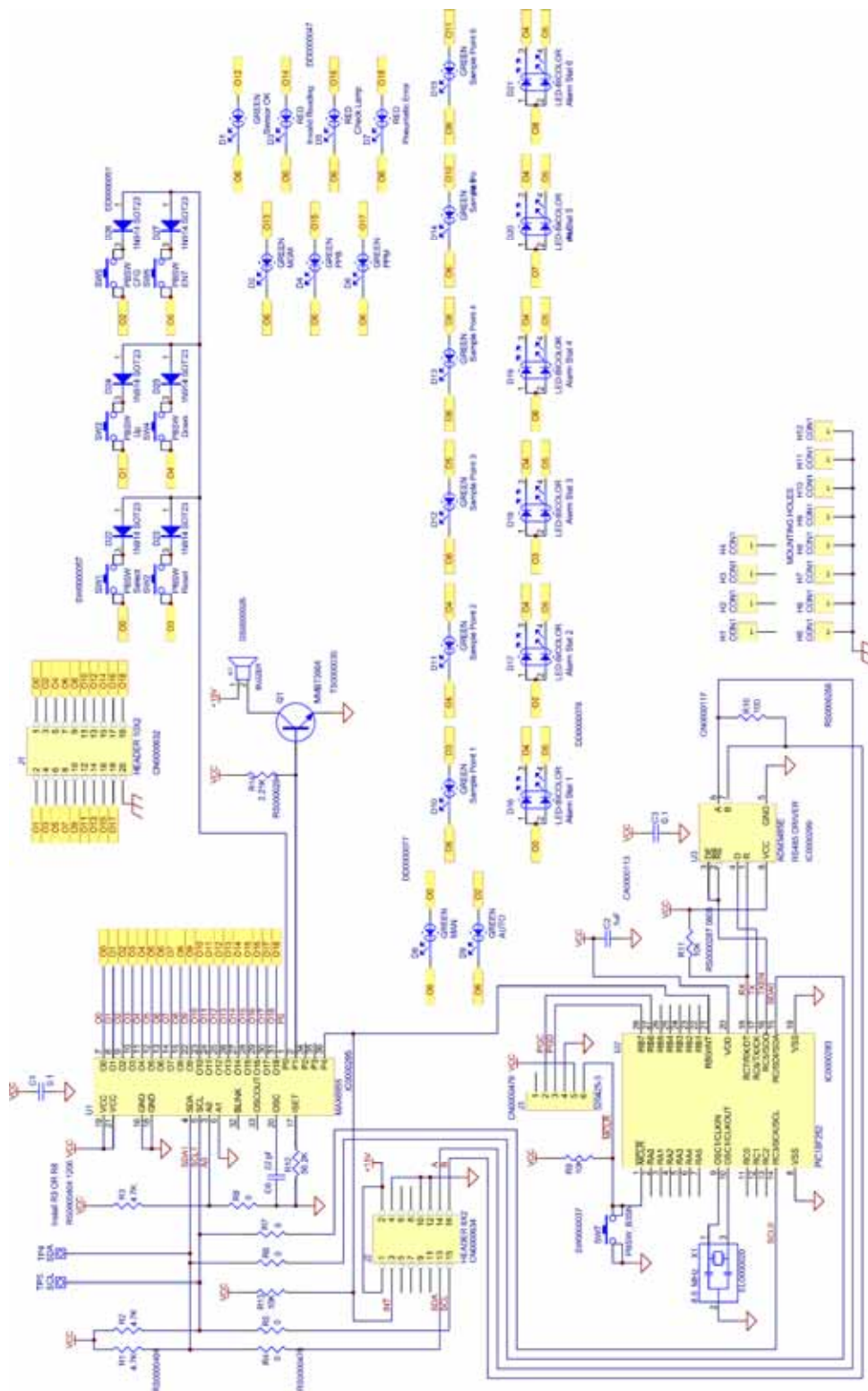

Front Panel 1 of 2

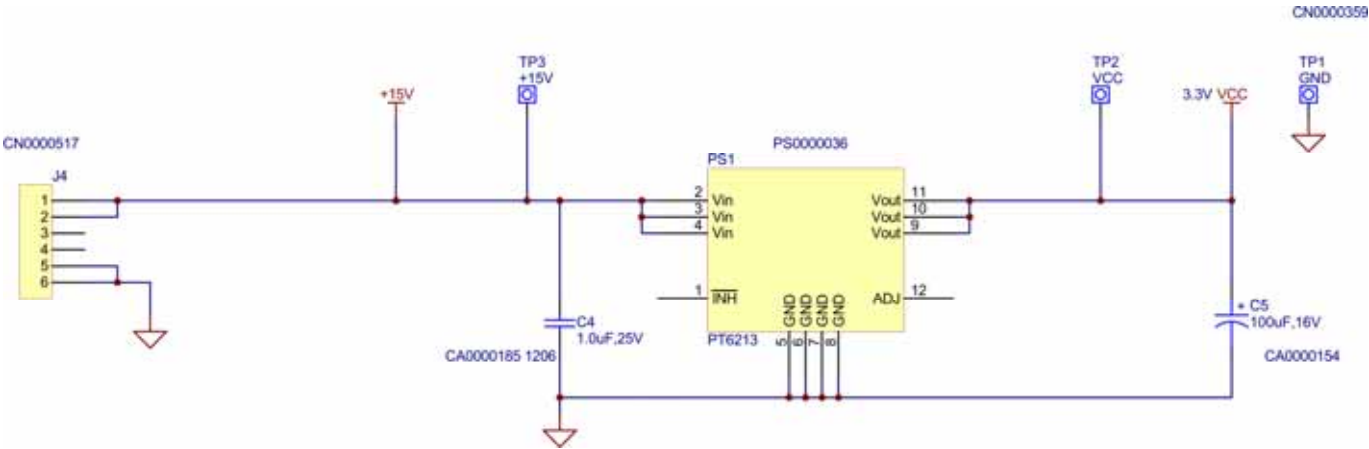

Front Panel 2 of 2

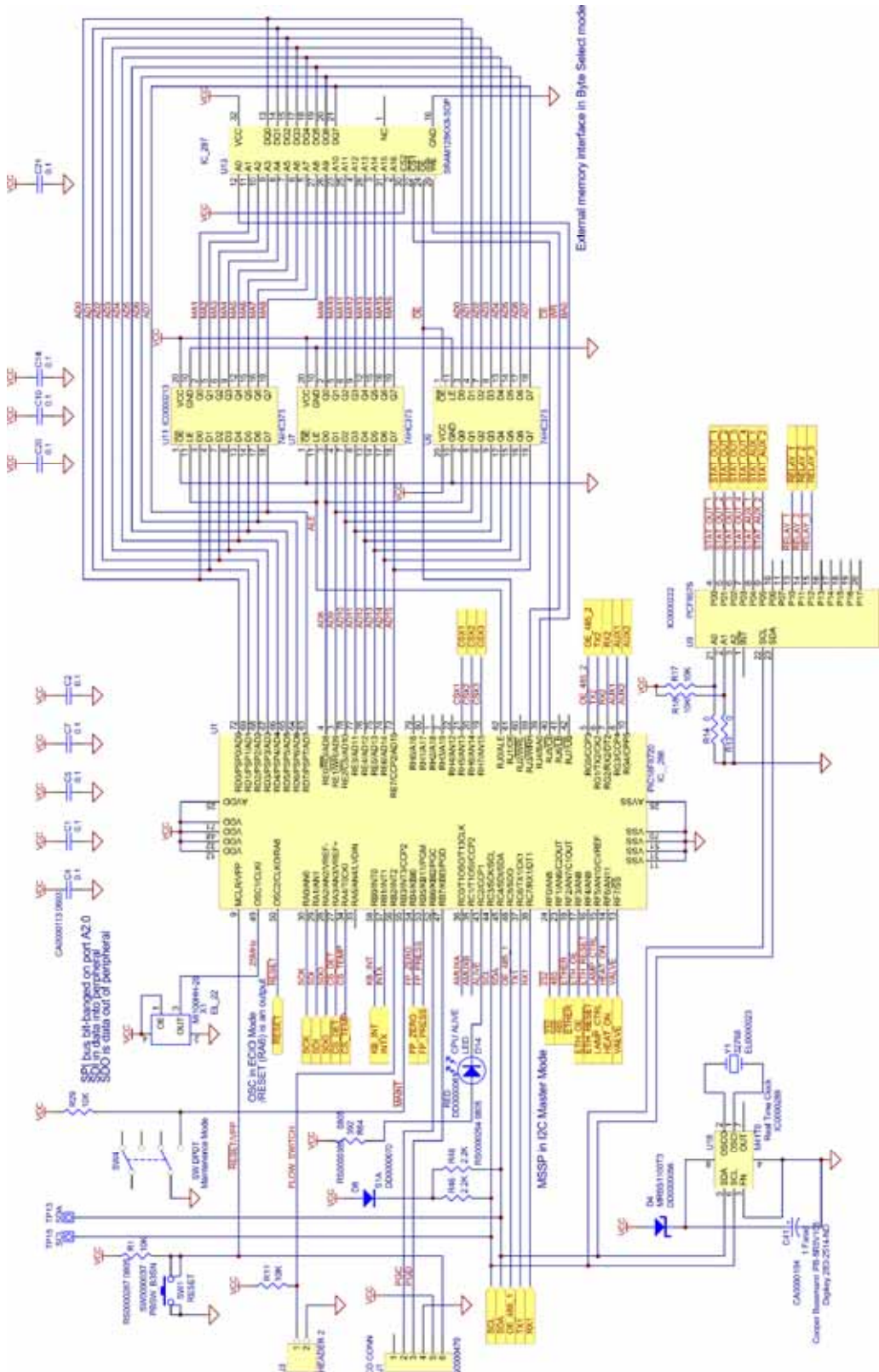

Main Board 1 of 6

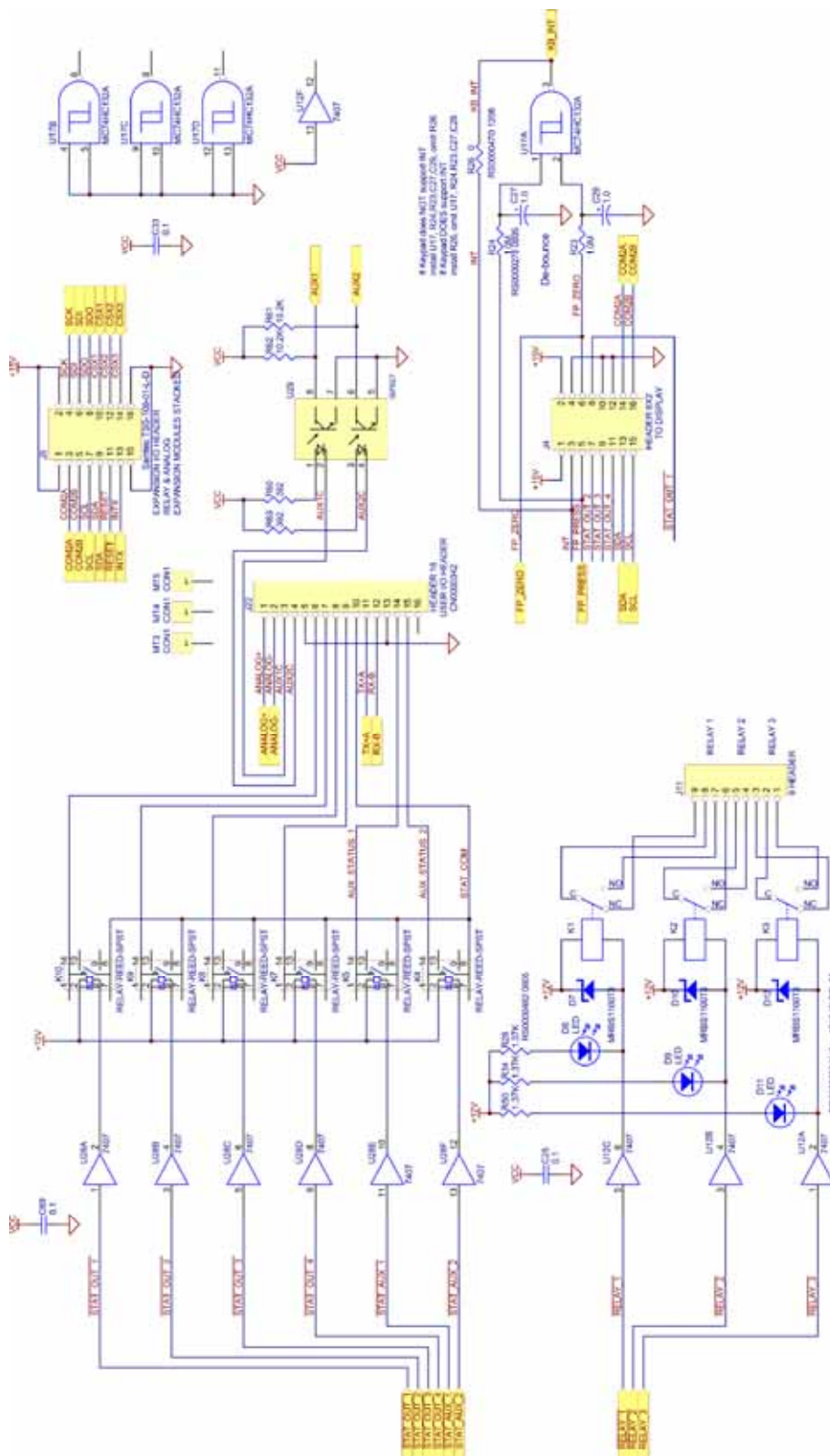

Main Board 2 of 6

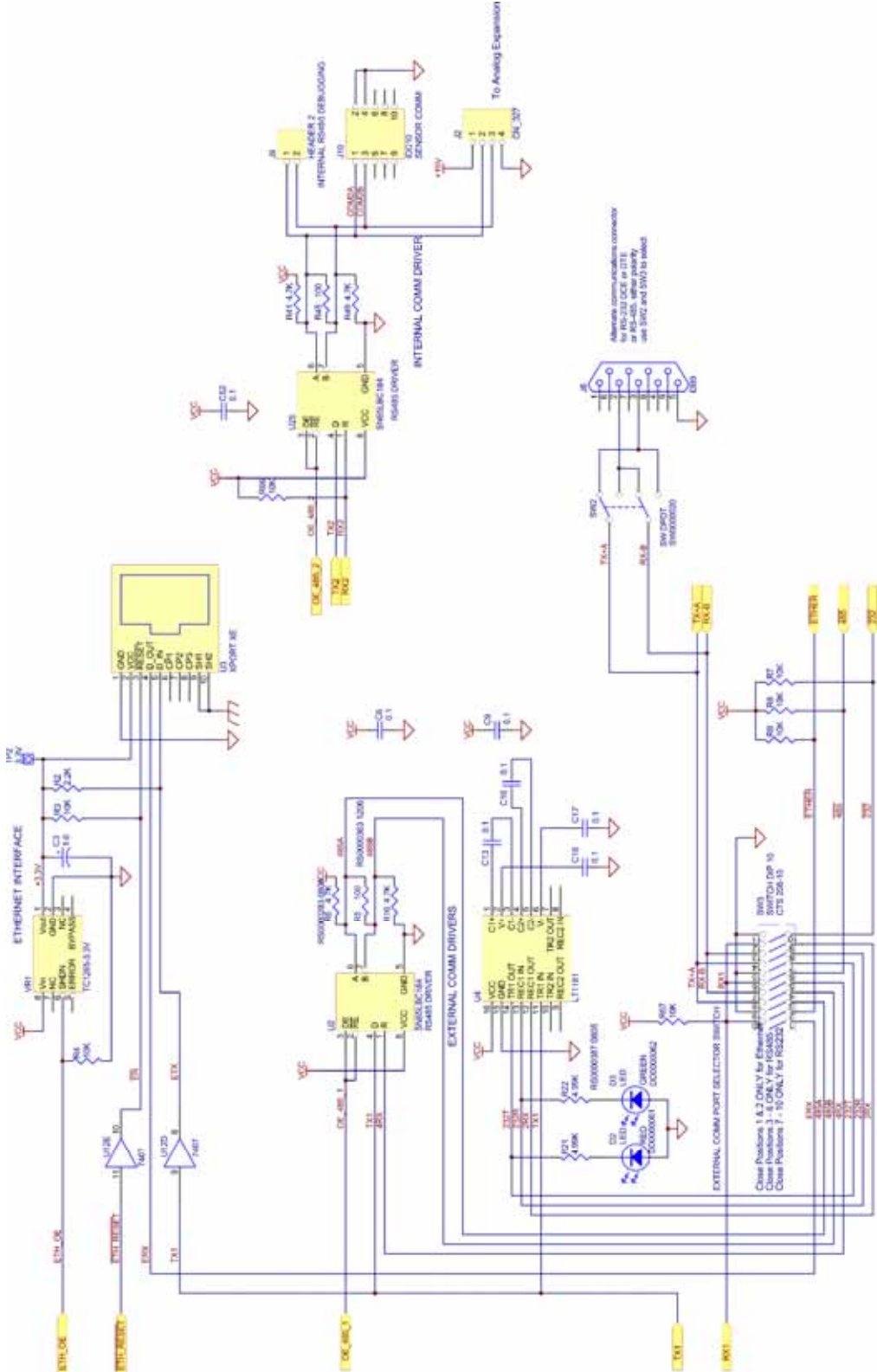

**Main Board 3 of 6**

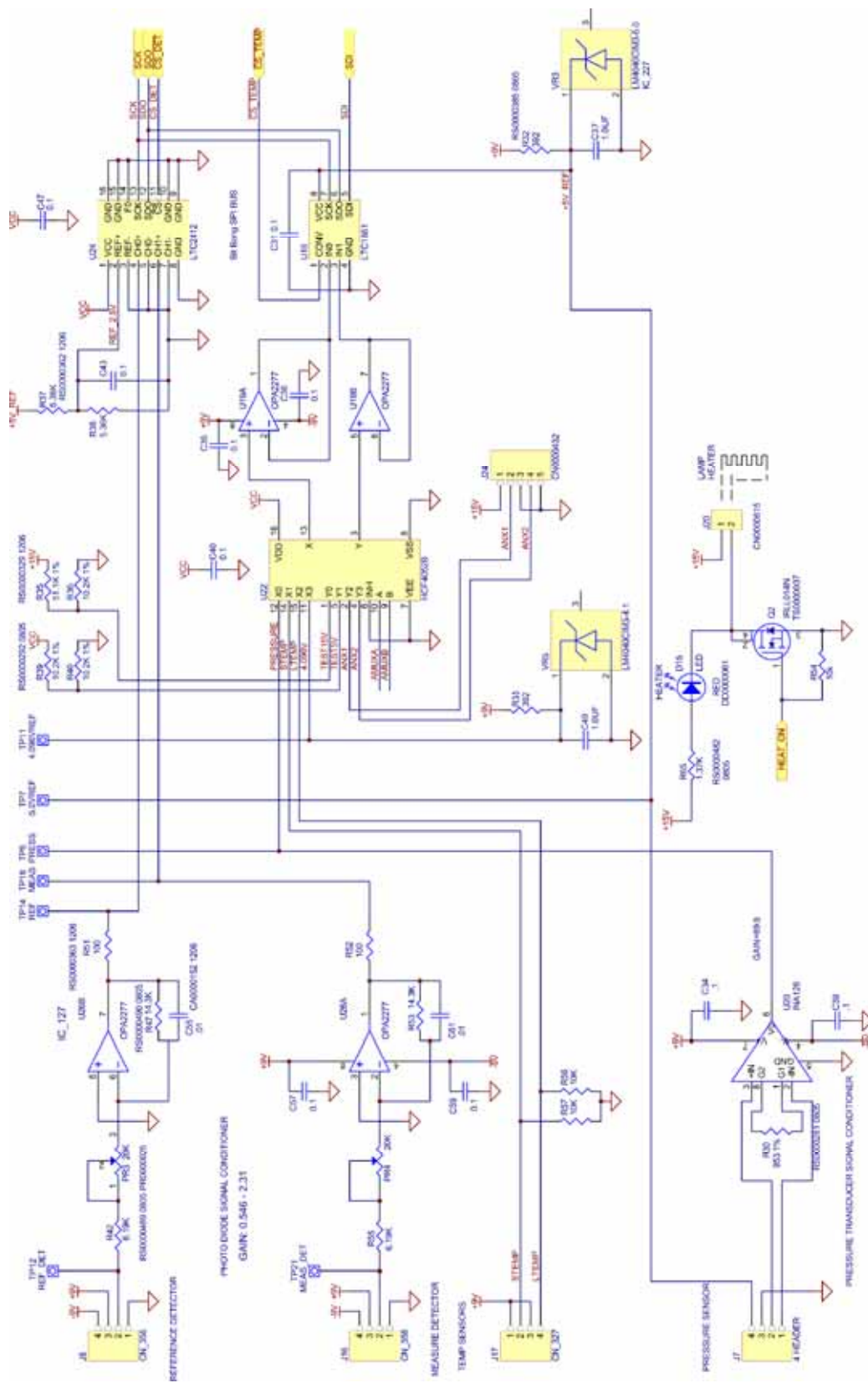

Main Board 4 of 6

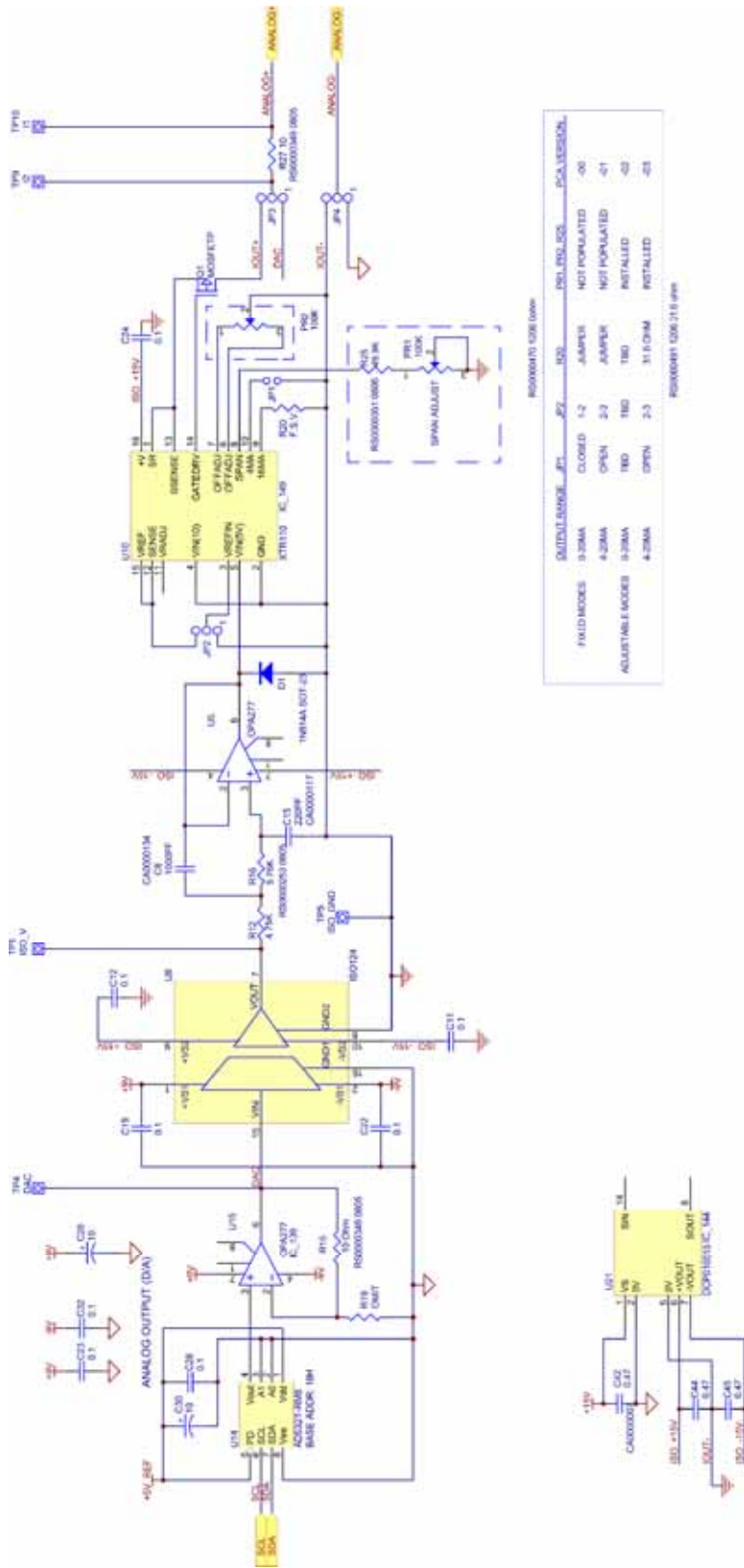

Main Board 5 of 6



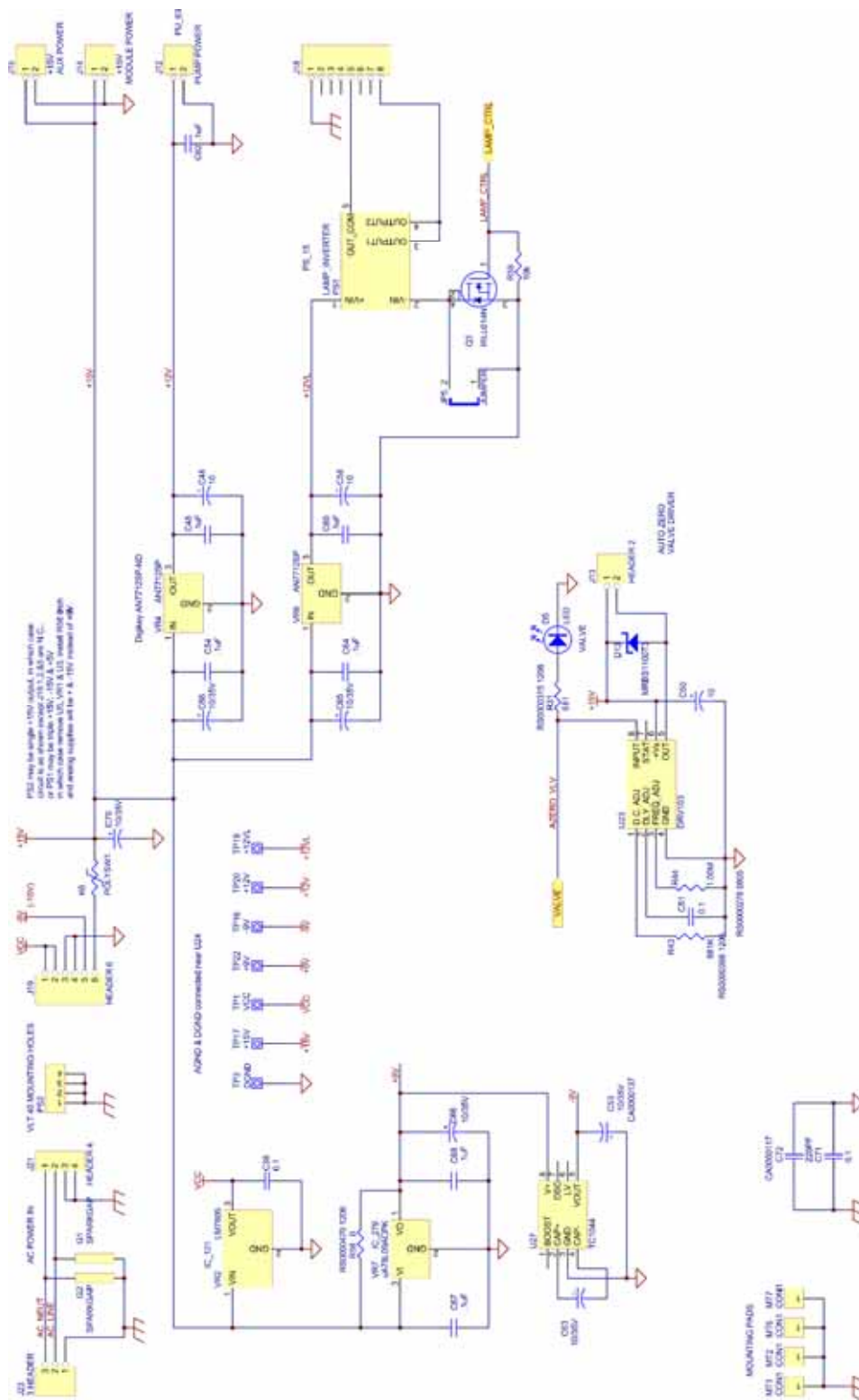

Main Board 6 of 6



## 10. SERVICE NOTES

### M465L Modbus Communication Setup

**I. PURPOSE:**

This document will go through how to setup your computer with “ModBus Reader” and use it to communicate to the M465L. It will also go through how to use it for data logging purposes.

**II. TOOLS:**

ModBus Reader with M465L Configuration files (Available on the Website under “software”)  
RS232 serial Cable

**III. PARTS:**

None



The electronics used in T-API analyzers are sensitive to Electrostatic Discharge (ESD). When working on any T-API device, please ensure that you are properly grounded prior to handling or touching any electronic circuitry in the analyzers! For more information on how to protect sensitive components from ESD during handling, please contact T-API customer service and ask for the ESD Service note number 03-022A.

**IV. PROCEDURE:**

1. “ModBus Reader” is a FREEWARE product of KurySoft. The FREEWARE is available at <http://www.kurysoft.com/download.shtml> or our website at, <http://www.teledyne-api.com/software/>. Please download “ModBus Reader” form one of these websites.
2. Please go to our website and download the **M465L configuration files**. If you choose to download ModBus Reader from our website, you should visit the Kurysoft website to review the “END-USER LICENSE AGREEMENT”
3. Connect a 9 pin serial cable from the RS232/485 port on the back of the analyzer to your computers serial port. Remove the cover of the analyzer and on the circuit board close to the location of the RS232 port you should see two LEDs. They are labeled D2 (red) and D3 (green). Both of these LEDs should be on. If they are not, switch the DCE/DTE switch on the back of the analyzer to the other position. Both lights should now be on, if they are not, check your cable connections again.
4. Unzip the “ModBus Reader” file and copy the .EXE file to your desktop. Double-click on the icon to begin the installation process. When you get to the Associated Extensions screen, you will want to check both the .mbc and .mbs boxes.
5. Unzip the M465L Configuration files and place both files in the same directory that ModBus Reader was installed into. The default for this is C:\Program Files\ModbusConstructor.
6. After the installation has been completed, launch ModBus Reader.
7. Go to FILE, OPEN, and open the file “M465L.mbs”.
8. Go to Connection and then COM Parameters and make sure that all of the settings are as follows

Port: COM1 (The serial port on your computer, most use COM1)  
Baud rate: 57600  
Parity: None  
Stop Bits: 1 stop bit

9. Once these settings are correct, click OK. Go to Mode and select Master Settings. Make sure the “Slave Address” is the same as the address on your M465L. The default for this value is “1”. To confirm the address on your analyzer follow the directions below.
  - a. At the instrument: Press Config
  - b. Press the Down Arrow 3 times
  - c. CONFIG will show on the display, Press Enter
  - d. Press the Down Arrow 1 time
  - e. ADDRESS will show on the display, Press Enter
  - f. The display will show COMM ADDRESS = (number)
  - g. Record the number, this is your analyzers Slave address
  - h. Press Config 3 times to return to the concentration display
10. Once the address has been entered into the Slave address, press OK. Go to Connection and make sure that COM1, or which ever com port you selected, has a check mark next to it. If it doesn't, select COM1.
11. Go to Connection and then to Connect. The boxes in interface screen should now be updating with numbers.

### **DATA LOGGING**

12. In the ModBus Reader program go to Tools and then Data Logging Setup. Make sure that the following settings are correct.
  - **Write to common file (by session)** is selected
  - **Write on every response** is checked
  - **Open new file on connection** is selected
  - **Save file every, minutes** is checked
  - **Absolute time** is selected
13. Once these values are selected press OK. Go to Tools and then select Start Data Log. The ModBus Reader will now start to save all of the values that are seen on the screen. This file is saved in the same directory as the one that the ModBus Reader was installed into. You can open this file in Excel or other program. The file is “TAB” delimited.

**NOTE:** If you wish to create your own user interface screen to communicate to the analyzer you can go to the website <http://www.kurysoft.com>. This has the ModBus Constructor program which has a free trial period but must be purchased after a trial period. This program can be used to create interfaces similar to the M465L interface.