

Model T100U ***Trace Level Sulfur Dioxide Analyzer***

Addendum to T100 Operation Manual, PN 06807

Also supports operation of:

Model T108U Analyzer

(when used in conjunction with both the T100 manual, PN 06807,
and the T108 addendum, PN 07268)

© TELEDYNE ADVANCED POLLUTION INSTRUMENTATION (TAPI)
9480 CARROLL PARK DRIVE
SAN DIEGO, CA 92121-5201
USA

Toll-free Phone: 800-324-5190

Phone: 858-657-9800

Fax: 858-657-9816

Email: api-sales@teledyne.com

Website: <http://www.teledyne-api.com/>

WARRANTY

See Warranty page in the T100 Manual - P/N 06807

ABOUT THIS MANUAL

This manual is to be used in conjunction with the Model T100 operation manual, part number 06807. Where operation of the Model T100U diverges from that of the Model T100, this manual addendum takes precedence. This T100U addendum is comprised of multiple documents, assembled as follows:

Part No.	Rev	Name/Description
06840	B	T100U Addendum to T100 Operation Manual
[See T100 manual for Appendix A, Menu Tree and related software documentation]		
06846	8/9/2011	Spare Parts List (in Appendix B of this addendum)
05946	A	Recommended Spares Stocking Levels (in Appendix B of this addendum)
05930	B	Appendix C, Repair Form

Documents included in Appendix D:

0736201	01	Interconnect List
07362	01	Interconnect Diagram
0506402	A	UV Ref PCA
05435	C	Internal PMT Preamp PCA
05466	B	Sync/Demod PCA
0591602	C	Bursting UV Lamp Drv Schem

REVISION HISTORY

2011, August 10, T100U Addendum, 06840 Rev B, DCN Updates				
Document	PN	Rev	DCN	Change Summary
T100U Addendum	06840	B	6201	Administrative Updates: <ul style="list-style-type: none"> • Reformatted layout. • Renamed “Theory of Operation” to “Principles of Operation” and moved to end (last section). • Renamed “Troubleshooting & Repair” to “Troubleshooting and Service”. • Corrected cross-references to sections/figures in T100 Operation Manual, 06807. Technical updates: <ul style="list-style-type: none"> • Removed reference to “shutter”. • Added North American Certifications to specs table Replaced Spare Parts List 06846 with most recent output to spreadsheet. Replaced Internal PMT Preamp schem 05435 Rev B with Rev C Replaced Sync/Demod PCA schem 05466 Rev A with Rev B.
2010, November 15, T100U Manual, PN06840 Rev A, DCN5908 Initial Release				

TABLE OF CONTENTS

1. PREFACE	7
1.1 Reference Numbering Convention	7
2. SPECIFICATIONS, APPROVALS AND WARRANTY	9
2.1 Specifications	9
2.2 EPA Equivalency Designation	10
2.3 CE Mark Compliance	10
3. GETTING STARTED	11
3.1 Unpacking the T100U	11
3.2 Internal Layouts	11
3.3 Functional Check of the T100U	13
3.3.1 Test Functions	13
4. T100U OPERATING INSTRUCTIONS	15
4.1 Additional Test Parameters	15
4.2 STBL MENU: Setup for the Three Stability Functions	15
5. CALIBRATION PROCEDURES	17
6. EPA PROTOCOL CALIBRATION	19
7. INSTRUMENT MAINTENANCE	21
8. TROUBLESHOOTING AND SERVICE	23
8.1.1 Fault Diagnosis with Warning Messages	23
8.1.2 Fault Diagnosis with Test Functions	24
8.1.3 Fault Diagnosis with Sync Demod PCA LEDs	25
8.2 Other Performance Problems	25
8.3 Additional Repair Procedures	25
8.3.1 UV Lamp Adjustment and/or Replacement	25
8.3.1.1 Adjusting the UV Lamp (<i>Peaking the Lamp</i>)	26
8.3.1.2 Replacing the UV Lamp	28
8.3.2 Replacing the UV Filter/Lens	29
8.3.3 Replacing the PMT, HVPS or TEC	30
8.3.4 T100U PMT Hardware Calibration (<i>Factory Cal</i>)	32
8.4 Technical Assistance	33
9. PRINCIPLES OF OPERATION	35
9.1 Electronic Operation	35
9.1.1 Sensor Module	35
9.1.1.1 Sample Chamber	38

LIST OF FIGURES

Figure 3-1:	T100U Internal Layout	12
Figure 3-2:	T100U Test Functions	14
Figure 4-1:	Accessing the STBL Menu	16
Figure 8-1:	UV Lamp Adjustment.....	27
Figure 8-2:	Disassembling the Sample Chamber/UV Source Assembly	29
Figure 8-3:	PMT Assembly - Exploded View.....	30
Figure 9-1:	Sensor Block Diagram	36
Figure 9-2:	T100U Sensor Module Assembly	37
Figure 9-3:	T100U Sample Chamber Exploded View	38

LIST OF TABLES

Table 2-1:	Model T100U Basic Unit Specifications.....	9
Table 3-1:	Test Functions Defined.....	13
Table 8-1:	Test Functions - Possible Causes for Out-Of-Range Values	24
Table 8-2:	Relay PCA Status LED Failure Indications.....	25

LIST OF APPENDICES

APPENDIX A: Menu Trees and Software Documentation (refer to Appendix A of the T100 manual)

APPENDIX B: Spare Parts List and Recommended Spares Stocking Levels

APPENDIX C: Warranty Repair Questionnaire

APPENDIX D: Schematics (contains those unique to T100U; other schematics in T100 manual)

This page intentionally left blank.

1. PREFACE

Note

The information contained in this addendum is pertinent to T100U analyzers running software revision Gc4. Some or all of the information may not be applicable to later revisions of software. The software revision that your analyzer is running is displayed in the Mode field of the display any time the analyzer is in SETUP mode.

This addendum is based on the Model T100 Operators Manual (P/N 06807). In most ways the T100U is identical to the T100 in design and operation; therefore, most of the basic set up information, operating instructions as well as calibration, maintenance, troubleshooting and repair methods are found in that manual. This addendum documents only those areas where the T100U is different in design or operating method from the T100.

Therefore, this addendum includes instructions and information regarding:

- Additional Test Functions
- Adjusting the PMT HV for “Factory Calibrations”
- Differences in theory of operation

1.1 REFERENCE NUMBERING CONVENTION

Unless otherwise specified, section, figure and table reference numbers referred to within this text are relative to this manual.

EXAMPLE: “Figure 2-1” refers to the figure within this document labeled as Figure 2-1.

References to sections, figures and tables in the T100 manual will be labeled as such.

EXAMPLE: “Figure 6-1 of the T100 Operators Manual” (P/N 06807).

This page intentionally left blank.

2. SPECIFICATIONS, APPROVALS AND WARRANTY

2.1 SPECIFICATIONS

Table 2-1: Model T100U Basic Unit Specifications

PARAMETER	SPECIFICATION
Ranges (Physical Analog Output)	Min: 0-5 ppb Full scale Max: 0-20 000 ppb Full scale (selectable, dual ranges and auto ranging supported)
Measurement Units	ppb, ppm, $\mu\text{g}/\text{m}^3$, mg/m^3 (selectable)
Zero Noise ²	25 ppt RMS (50 ppt RMS with 360 nm filter installed)
Span Noise ²	0.5% of reading RMS, above 5 ppb
Lower Detectable Limit ³	50 ppt RMS
Zero Drift (24 hours)	< 0.2 ppb (<.4 ppb with 360 nm filter installed)
Span Drift (24 hours)	< 0.5% of full scale
Lag Time ¹	30 seconds
Rise/Fall Time ¹	< 140 seconds to 95%
Linearity	1% of full scale
Precision	0.5% of reading
Sample Flow Rate	650 cm^3/min . $\pm 10\%$
AC Power Rating	100 V-120V, 220 – 240 V, 50/60 Hz
Analog Output Ranges	10 V, 5 V, 1 V, 0.1 V, 2-20 or 4-20 mA isolated current loop. All Ranges with 5% Under/Over Range
Recorder Offset:	$\pm 10\%$
Standard I/O	1 Ethernet: 10/100Base-T 2 RS-232 (300 – 115,200 baud) 2 USB device ports 8 opto-isolated digital status outputs 6 opto-isolated digital control inputs (3 defined, 3 spare) 4 analog outputs
Optional I/O	1 USB com port 1 RS485 8 analog inputs (0-10V, 12-bit) 4 digital alarm outputs Multidrop RS232 3 4-20mA current outputs

PARAMETER	SPECIFICATION
Analog Output Resolution	1 part in 4096 of selected full-scale voltage
Temperature Coefficient	< 0.1% per °C
Temperature Range	5-40 °C
Humidity Range	0 - 95% RH, non-condensing
Dimensions H x W x D	7" x 17" x 23.5" (178 mm x 432 mm x 597 mm)
Weight, Analyzer (Basic Configuration)	45 lbs (20.5 kg) w/internal pump
Environmental	Installation category (over-voltage category) II; Pollution degree 2
Certifications	EQSA-0495-100 EN61326 (1997 w/A1: 98) Class A, FCC Part 15 Subpart B Section 15.107 Class A, ICES-003 Class A (ANSI C63.4 1992) & AS/NZS 3548 (w/A1 & A2; 97) Class A. IEC 61010-1:90 + A1:92 + A2:95, North American Certifications: <ul style="list-style-type: none"> • cNEMKO (Canada): CAN/CSA-C22.2 No. 61010-1-04 • NEMKO-CCL (us): UL No. 61010-1 (2nd Edition)
¹ As defined by the USEPA ² 25 samples taken, 10 sec. interval ³ Twice zero noise	

2.2 EPA EQUIVALENCY DESIGNATION

Teledyne API's T100U trace level sulfur dioxide analyzer is designated as a reference method for SO₂ measurement, as defined in 40 CFR Part 53, when operated under the conditions defined for the T100 analyzer (manual PN 06807).

2.3 CE MARK COMPLIANCE

The T100U analyzer emissions and safety compliance are the same as those for the T100 analyzer.

3. GETTING STARTED

3.1 UNPACKING THE T100U

Unpack the T100U as per the directions in Section 3.1 of the T100 Manual, with the following change: There are two redheaded shipping screws that hold down the PMT/Sensor assembly and must be removed prior to operation. They are located along the base of the PMT housing adjacent to the chassis.

3.2 INTERNAL LAYOUTS

Figure 3-1 replaces Figure 3-5 in the T100 manual. The primary difference between the T100U and T100 layouts is the differences in the PMT Housing, the location of the PMT preamp PCA and the addition of a Sync Demodulator PCA.

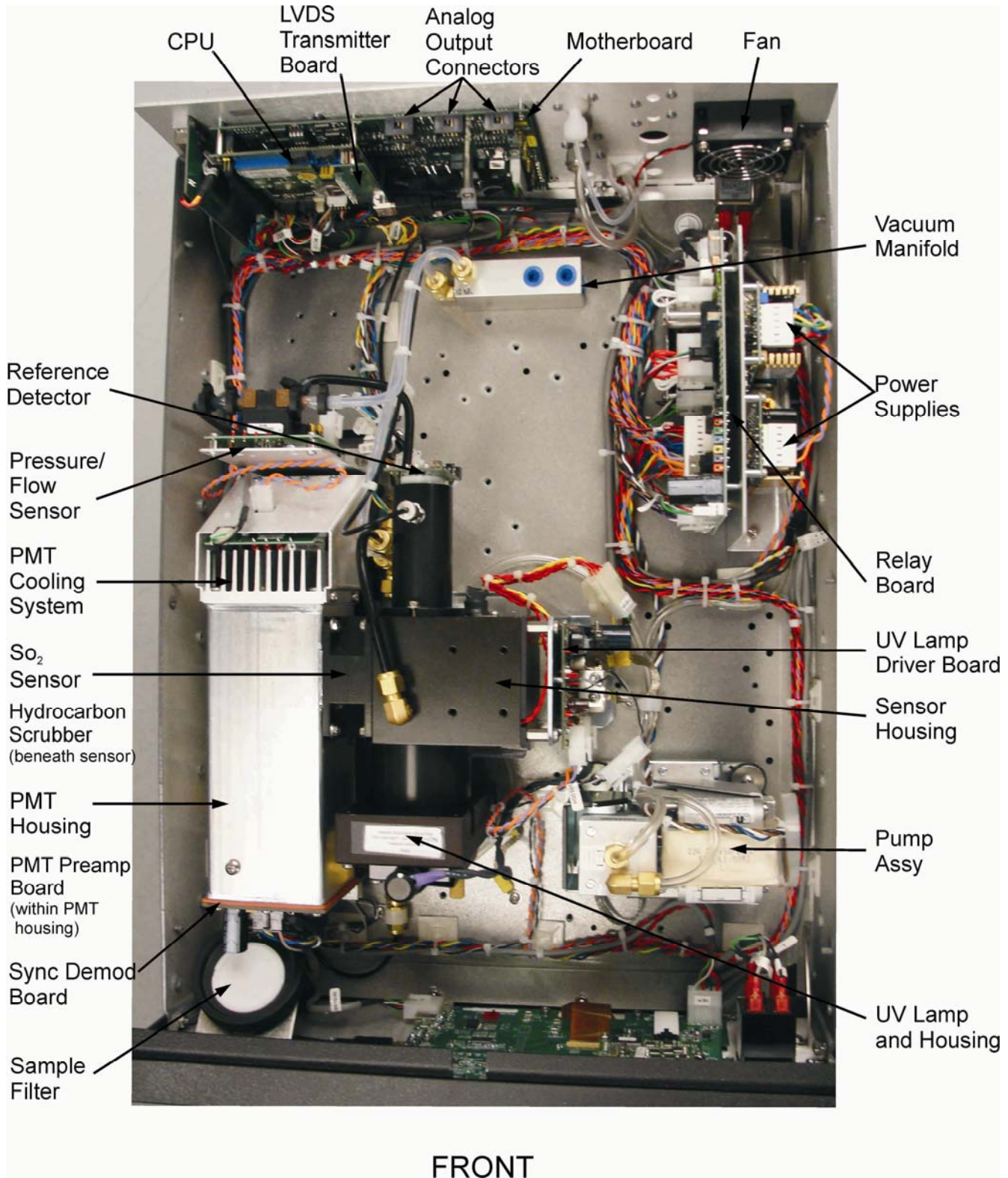

Figure 3-1: T100U Internal Layout

3.3 FUNCTIONAL CHECK OF THE T100U

To perform an initial functional check of the T100U follow the steps contained in Section 3.4 of the T100 Manual, but use the Test functions described in below.

3.3.1 TEST FUNCTIONS

Table 3-1 of this addendum supersedes Table 4-2 in Section 4.1.1 of the T100 manual, and Figure 3.2 in this addendum replaces Figure 3-24 of the T100 Manual.

Table 3-1: Test Functions Defined

DISPLAY	PARAMETER	UNITS	DESCRIPTION
RANGE	RANGE -- RANGE1 RANGE2	PPB, PPM, UGM & MGM	The Full Scale limit at which the reporting range of the analyzer's ANALOG OUTPUTS is currently set. THIS IS NOT the Physical Range of the instrument. See Section 4.6 of T100 manual for more information. If DUAL or AUTO Range modes have been selected, two RANGE functions will appear, one for each range.
STABIL	STABILITY	ppb	Standard deviation of SO ₂ Concentration readings. Data points are recorded every ten seconds. The calculation uses the last 25 data points.
STABIL2	STABILITY	ppb	Standard deviation of SO ₂ Concentration readings, per EPA. Data points are recorded every 120 seconds. The calculation uses the last 25 data points.
PRES	SAMPLE PRESSURE	in-Hg-A	The current pressure of the sample gas as it leaves the sample chamber.
SAMP FL	SAMPLE FLOW	cm ³ /min (cc/m)	The flow rate of the sample gas through the sample chamber.
PMT	PMT Signal	mV	The raw output voltage of the PMT.
NORM PMT	NORMALIZED PMT Signal	mV	The output voltage of the PMT after normalization for offset and temperature/pressure compensation (if activated).
UV LAMP	Source UV Lamp Intensity	mV	The output voltage of the UV reference detector.
UV STAB	Stability of UV Lamp Intensity	mV	Standard deviation of UV reference detector output. Data points are recorded every ten seconds. The calculation uses the last 25 data points.
LAMP RATIO	UV Source lamp ratio	%	The current output of the UV reference detector divided by the reading stored in the CPU's memory from the last time a UV Lamp calibration was performed.
STR. LGT	Stray Light	ppb	The offset due to stray light recorded by the CPU during the last zero-point calibration performed.
DRK PMT	Dark PMT	mV	The PMT output reading recorded as the lamp pulses off during normal measurement.
DRK LMP	Dark UV Source Lamp	mV	The UV reference detector output reading recorded as the lamp pulses off during normal measurement.
SLOPE	SO ₂ measurement Slope	-	The sensitivity of the instrument as calculated during the last calibration activity. The slope parameter is used to set the span calibration point of the analyzer.
OFFSET	SO ₂ measurement Offset	-	The overall offset of the instrument as calculated during the last calibration activity. The offset parameter is used to set the zero point of the analyzer response.
HVPS	HVPS	V	The PMT high voltage power supply.

DISPLAY	PARAMETER	UNITS	DESCRIPTION
RCELL TEMP	SAMPLE CHAMBER TEMP	°C	The current temperature of the sample chamber.
BOX TEMP	BOX TEMPERATURE	°C	The ambient temperature of the inside of the analyzer case.
PMT TEMP	PMT TEMPERATURE	°C	The current temperature of the PMT.
IZS TEMP ¹	IZS TEMPERATURE ¹	°C	The current temperature of the internal zero/span option. Only appears when IZS option is enabled
TEST ²	TEST SIGNAL ²	mV	Signal of a user-defined test function on output channel A4.
TIME	CLOCK TIME	hh:mm:ss	The current day time for DAS records and calibration events.

To view the TEST Functions press the following menu selection sequence:

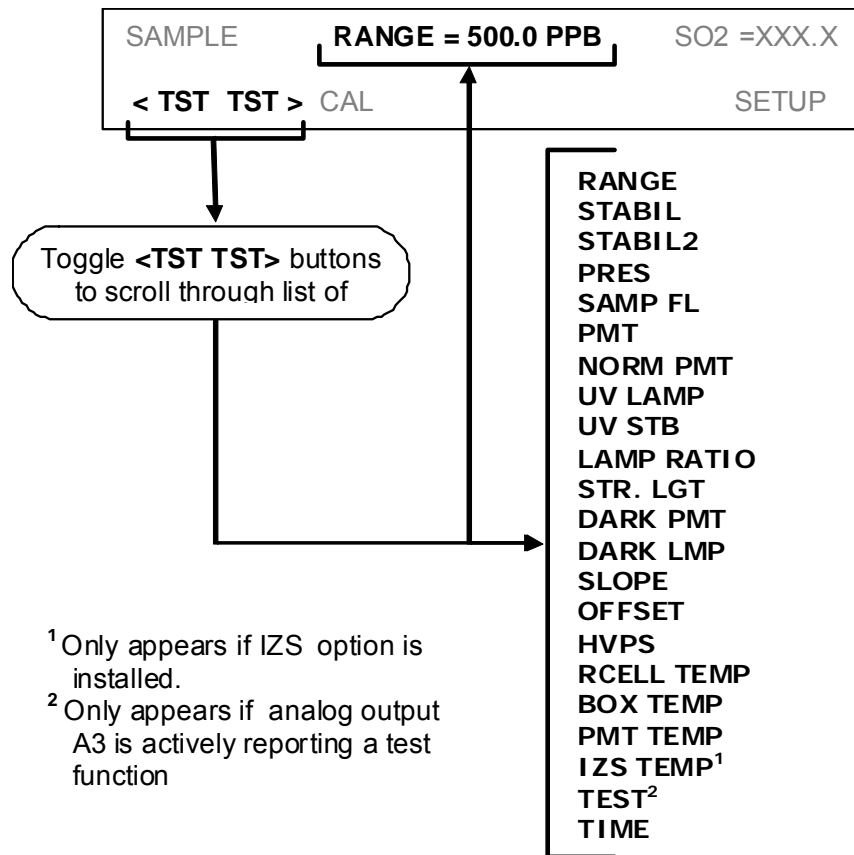

¹ Only appears if IZS option is installed.
² Only appears if analog output A3 is actively reporting a test function

Figure 3-2: T100U Test Functions

4. T100U OPERATING INSTRUCTIONS

Note

For the most part the operation instructions for the T100U are the same as those described in the T100 Manual with the exception that there are additional test parameters and setup procedures.

4.1 ADDITIONAL TEST PARAMETERS

Please see Section 3.3 of this addendum for details on the additional test parameters.

4.2 STBL MENU: SETUP FOR THE THREE STABILITY FUNCTIONS

There is an additional submenu on the Secondary Setup Menu in the T100U's software. The STBL menu, see Figure 4-1 allows the user to modify the settings for the three stability calculations that are displayed as Test Functions on the front panel and are available via the serial data port and that can be logged with the DAS. Test Function STABIL, CONC1 in the menus below, is equivalent to the standard T100 STABIL function and is useful when conducting calibrations and other operations in which the operator has limited time to view the display. CONC2, which is the same as the STABIL2 test function has been configured so that it calculates stability in the same way as required by the EPA. STABIL2 is useful when comparing instruments against the EPA standard but is very slow and difficult to use for calibration or other activities where the operator must wait for analyzer to settle to the desired value. UVLAMP is the same as UV STAB on the front panel is a diagnostic that can be used to understand the stability of the UV lamp.

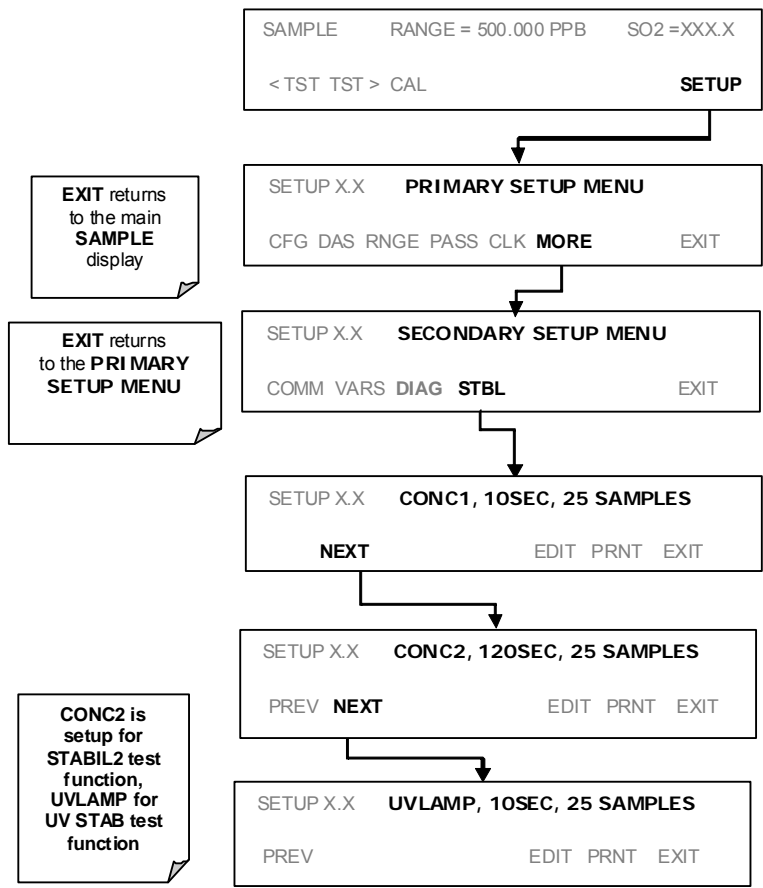

Figure 4-1: Accessing the STBL Menu

5. CALIBRATION PROCEDURES

Calibration of the T100U should be performed according to the procedures described in the T100 Manual. However, delivering span and zero gases for the lower ranges that the T100U is designed for can be difficult. For best results when calibrating the T100U, wait **one hour** for the instrument to stabilize when delivering zero and span gases before pressing the zero and span buttons. Attention must be paid to the quality of the gasses, the level of contaminants in the gases as well as the history and conditioning of the gas delivery components. Only Teflon or glass should be used for any “wetted” surfaces that the calibration gasses contact. All delivery system components should be conditioned by running span gas for a minimum of four hours before conducting actual span calibrations.

This page intentionally left blank.

6. EPA PROTOCOL CALIBRATION

For EPA Protocol calibration please refer to Section 10 of the T100 manual.

This page intentionally left blank.

7. INSTRUMENT MAINTENANCE

Instrument maintenance is almost identical to that in the T100. The T100U uses a 1 micron sample filter, instead of the 5 micron sample filter used in the T100. Replacement part numbers are shown below.

Part Number	Description
009690200	AKIT, TFE FLTR ELEMENT, 47MM, 1UM (100)
05920	UV Zinc LAMP, T100U

For all other maintenance questions, please refer to section 8 in the T100 manual.

This page intentionally left blank.

8. TROUBLESHOOTING AND SERVICE

This section includes various troubleshooting and repair information that either supplements or is in addition to that included in Section 12 of the T100 Manual

CAUTION



The operations outlined in this Section must be performed by qualified maintenance personnel only.

Please read Section 12 of the T100 Manual before attempting the following trouble shooting or repair procedures

WARNING - RISK OF ELECTRICAL SHOCK.



Some operations need to be carried out with the analyzer open and running.

Exercise caution to avoid electrical shocks and electrostatic or mechanical damage to the analyzer.

Do not drop tools into the analyzer or leave those after your procedures.

Do not shorten or touch electric connections with metallic tools while operating inside the analyzer.

Use common sense when operating inside a running analyzer.

8.1.1 FAULT DIAGNOSIS WITH WARNING MESSAGES

The warning messages for the T100U are identical to those included in Section 12.1.1 of the T100 Manual.

8.1.2 FAULT DIAGNOSIS WITH TEST FUNCTIONS

The following table supersedes Table 12.2 of the T100 Manual.

Table 8-1: Test Functions - Possible Causes for Out-Of-Range Values

TEST FUNCTION	NOMINAL VALUE(S)	POSSIBLE CAUSE(S)
STABIL (STANDARD)	≤0.075 ppb with zero air	Faults that cause high stability values are: pneumatic leak; low or very unstable UV lamp output; light leak; faulty HVPS; defective preamp board; aging PMT; PMT recently exposed to room light; dirty/contaminated reaction cell.
STABIL2 (EPA DEF)	≤0.075 ppb with zero air	Same as STABIL
SAMPLE FL	650 cm ³ /min ± 10%	Faults can be caused by: clogged critical flow orifice; pneumatic leak; faulty flow sensor; sample line flow restriction.
PMT	-20 TO 150 mV with zero air	High or noisy readings could be due to: calibration error; pneumatic leak; light leak (improper assembly); aging UV filter; low UV reference output; PMT recently exposed to room light; light leak in reaction cell; reaction cell contaminated; HVPS problem. <i>It takes 24-48 hours for a PMT exposed to ambient light levels to return to normal functioning.</i>
NORM PMT	--	Noisy Norm PMT value (assuming unchanging SO ₂ concentration of sample gas): Calibration error; HVPS problem; PMT problem; UV reference problem; UV lamp problem.
UV LAMP	2000 - 4400 mV	This is the instantaneous reading of the UV lamp intensity. Low UV lamp intensity could be due to: aging UV lamp; UV lamp position out of alignment; faulty lamp transformer; aging or faulty UV detector; dirty optical components. Intensity lower than 600 mV will cause UV LAMP WARNING .
UV STAB	0 to 100 mV	Unstable lamp or failed UV lamp driver.
LAMP RATIO	—	The current output of the UV reference detector divided by the reading stored in the CPU's memory from the last time a UV Lamp calibration was performed. Out of range lamp ratio could be due to: malfunctioning UV lamp; UV lamp position out of alignment; faulty lamp transformer; aging or faulty UV detector; dirty optical components; pin holes or scratches in the UV optical filters; light leaks.
STR LGT	<100 ppb	High stray light could be caused by: aging UV filter; contaminated reaction cell; light leak; pneumatic leak.
DRK PMT	200 - 325 mV	High dark PMT reading could be due to: light leak; high pmt temperature; high electronic offset.
DRK LMP	-50 - 200 mV	High dark UV detector could be caused by: light leak; high electronic offset.
HVPS	≈ 400 V to 900 V	Incorrect HVPS reading could be caused by; HVPS broken; preamp board circuit problems.
RCELL TEMP	50°C ± 1°C	Incorrect temperature reading could be caused by: malfunctioning heater; relay board communication (I ² C bus); relay burnt out
BOX TEMP	ambient + ~ 5°C	Incorrect temperature reading could be caused by: Environment out of temperature operating range; broken thermistor; runaway heater
PMT TEMP	7°C ± 2°C constant	Incorrect temperature reading could be caused by: TEC cooling circuit broken; High chassis temperature; 12V power supply
IZS TEMP (OPTION)	50°C ± 1°C	Malfunctioning heater; relay board communication (I ¹ C bus); relay burnt out
PRESS	ambient ± 2 IN-HG-A	Incorrect SAMPLE pressure could be due to: pneumatic leak; malfunctioning valve; malfunctioning pump; clogged flow orifices; sample inlet overpressure; faulty pressure sensor
SLOPE	1.0 ± 0.3	Slope out of range could be due to: poor calibration quality ; span gas concentration incorrect; leaks; UV Lamp output decay.
OFFSET	< 250 mV	High offset could be due to: incorrect span gas concentration/contaminated zero air/leak; low-level calibration off; light leak; aging UV filter; contaminated reaction cell; pneumatic leak.
TIME OF DAY	Current time	Incorrect Time could be caused by: Internal clock drifting; move across time zones; daylight savings time?

8.1.3 FAULT DIAGNOSIS WITH SYNC DEMOD PCA LEDS

There are four green Light Emitting Diodes (LEDs) on the bottom left side of the Sync Demodulator PCA. They indicate various statuses and can be used to troubleshoot problems associated with the board.

Table 8-2: Relay PCA Status LED Failure Indications

Indicator	Function	Description	Action
DS4	Watchdog	Toggles on or off every second	Steady on or off controller on PCA has crashed, PMT temp. control still operates but PMT, REF and PMT Temp voltages as shown in test functions will be XXXX. Press reset button on sync demod to restart; if problem continues check power supply voltages on PCA or PCA is failing and must be replaced.
DS3	I2C Activity	Flashes each time sync demod is polled by instrument CPU once every 1 to 1.5 seconds	Steady on or off indicates I ² C bus failure check wiring harness taking I ² C to motherboard, another I ² C device is hanging bus, I ² C transceiver on motherboard has failed, or CPU has problem.
DS2	A/D Status 1	Short frequent flashes tracks timing of A/D converter	Lack of flash indicates internal failure of A/D or firmware. Press reset button on sync demod to restart; if problem continues check power supply voltages on PCA or PCA is failing and must be replaced.
DS1	A/D Status 2		

8.2 OTHER PERFORMANCE PROBLEMS

Please refer to Section 12.5 of the T100 manual for information.

8.3 ADDITIONAL REPAIR PROCEDURES

The following repair procedures are in addition to those listed in Section 12.7 of the T100 Manual,

8.3.1 UV LAMP ADJUSTMENT AND/OR REPLACEMENT

There are two ways in which ambient conditions can affect the UV Lamp output and therefore the accuracy of the SO₂ concentration measurement: lamp aging and lamp positioning.

LAMP AGING

Over a period of months, the UV energy will show a downward trend, usually 30% - 50% in the first 90 days, and then a slower rate, until the end of useful life of the lamp. Periodically running the UV lamp calibration routine (see Section 5.9.6 of the T100 Manual) will compensate for this until the lamp output becomes too low to function at all, 2-3 years nominally.

LAMP POSITIONING

The UV output level of the lamp is uneven across the entire length of the lamp. Some portions of the lamp shine slightly more brightly than others. At the factory the position of the UV lamp is adjusted to optimize the amount of UV light shining through the UV filter/lens and into the reaction cell. Changes to the physical alignment of the lamp can affect the analyzer’s ability to accurately measure SO₂. See Section 12.7.2.5 of the T100 Manual for instructions on adjusting the lamp position.

8.3.1.1 Adjusting the UV Lamp (*Peaking the Lamp*)



CAUTION – GENERAL SAFETY HAZARD

Always wear safety glasses made with UV blocking material when working with the UV Lamp assembly. (Generic plastic safety glasses are not adequate).

1. Set the analyzer display to show the signal I/O function, **UVLAMP_SIGNAL** (see Section 12.1.3 of the T100 Manual).
2. Slightly loosen the large brass thumbscrew located on the shutter housing (see Figure 8-1) so that the lamp can be moved.
3. While watching the **UVLAMP_SIGNAL** reading, slowly rotate the lamp or move it back and forth vertically until the **UVLAMP_SIGNAL** reading is at its maximum.
 - Best peak intensity will occur when the dot (or arrow) on top of the lamp is pointing in the direction of the reaction cell.
 - Ideally, the reading should be 4000mV±200mV.
 - If **UVLAMP_SIGNAL** is lower than 600mV, replace the lamp.
 - If **UVLAMP_SIGNAL** is greater than 4400 mV, adjust the pot on the UV reference board down until the output reads 4400 mV, and then continue to peak the lamp.

ATTENTION

**-----
 COULD DAMAGE INSTRUMENT AND VOID WARRANTY**

DO NOT grasp the UV lamp by its cap when changing its position - always grasp the main body of the lamp (refer to Figure 8-1). Inattention to this detail could twist and potentially disconnect the lamp’s power supply wires.

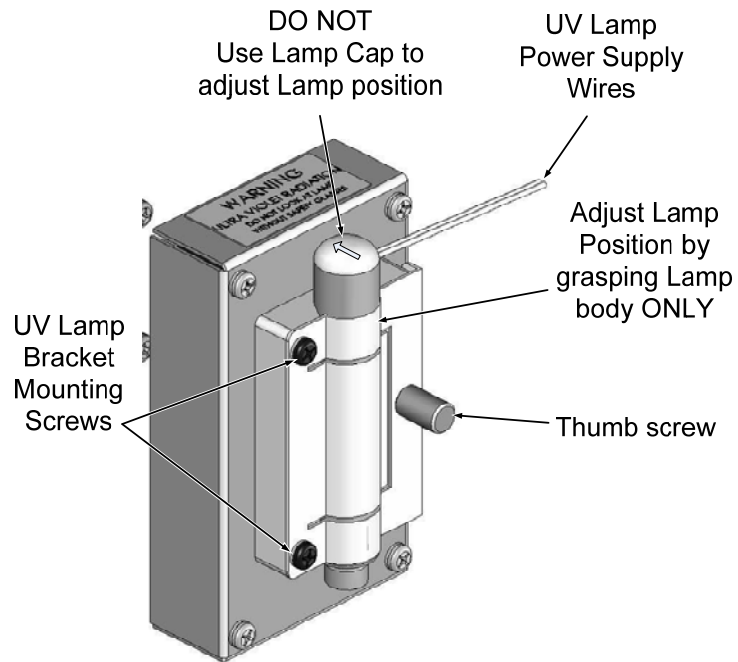

Figure 8-1: UV Lamp Adjustment

4. Finger tighten the thumbscrew.



CAUTION - GENERAL SAFETY HAZARD

DO NOT over tighten the thumbscrew, as over-tightening can cause breakage to the lamp and consequently release mercury into the area.

8.3.1.2 Replacing the UV Lamp



CAUTION – GENERAL SAFETY HAZARD

Always wear safety glasses made with UV blocking material when working with the UV Lamp assembly. (Generic plastic safety glasses are not adequate).

1. Turn off the analyzer.
2. Disconnect the UV lamp from its power supply.
 - You can find the power supply connector by following the two, white UV Lamp power supply wires from the lamp to the power supply.
3. Loosen, but do not remove the two UV lamp bracket screws, and the large brass thumbscrew located on the shutter housing (see Figure 8-2) so that the lamp can be moved.

ATTENTION

**-----
 COULD DAMAGE INSTRUMENT AND VOID WARRANTY**

Do not grasp the UV lamp by its cap when changing its position (see Figure 8-2). Always grasp the main body of the lamp. Inattention to this detail could twist and potentially disconnect the lamp’s power supply wires.

4. Remove the UV Lamp by pulling it straight up.
5. Insert the new UV lamp into the bracket.
6. Tighten the two UV lamp bracket screws, but leave the brass thumb screw un-tightened.
7. Connect the new UV lamp to the power supply.
8. Turn the instrument on and perform the UV adjustment procedure as defined in section 8.3.1.1 of this addendum.
9. Finger tighten the thumbscrew.



CAUTION - GENERAL SAFETY HAZARD

DO NOT over tighten the thumbscrew, as over-tightening can cause breakage to the lamp and consequently release mercury into the area.

10. Perform a lamp calibration procedure (see Section 4.8.7 of the T100 Manual) and a zero point and span point calibration (see Section 9 of the T100 Manual).

8.3.2 REPLACING THE UV FILTER/LENS

IMPORTANT

IMPACT ON READINGS OR DATA

Be careful not to leave thumbprints on the interior of the sample chamber. The various oils that make up fingerprints fluoresce brightly under UV light and will significantly affect the accuracy of the analyzer's SO₂ measurement.

1. Turn off the instrument's power and remove the power cord from the instrument.
2. Unplug the J4 connector from the motherboard to allow tool access.
3. Remove 4 screws from the lamp housing cover (see Figure 8-2) and remove the cover .
4. Remove 4 screws from the UV filter retainer.

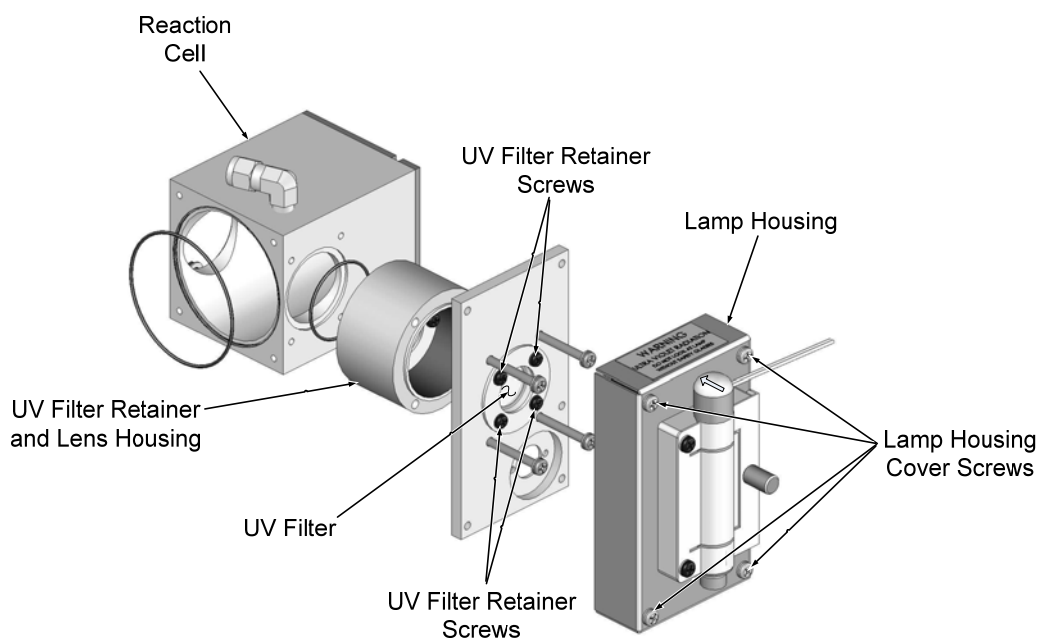

Figure 8-2: Disassembling the Sample Chamber/UV Source Assembly

IMPORTANT

IMPACT ON READINGS OR DATA

Never touch the filter's surface; fingertips can leave oily residue and will significantly affect the accuracy of the analyzer's SO₂ measurement. Handle carefully by the outer edges.

5. Carefully remove the UV filter.
6. Install the UV filter with arrow pointing towards reaction cell. Handle carefully and never touch the filter's surface. The UV filter's wider (ring) side should be facing out. Install the UV filter retainer and tighten screws.
7. Install the lamp housing cover and mini-fit connector. Tighten 4 screws.
8. Re-plug J4 connector into the motherboard.

8.3.3 REPLACING THE PMT, HVPS OR TEC

The PMT should last for the lifetime of the analyzer. However, in some cases, the high voltage power supply (HVPS) or the thermo-electric cooler (TEC) may fail. To replace the PMT, the HVPS or the TEC:

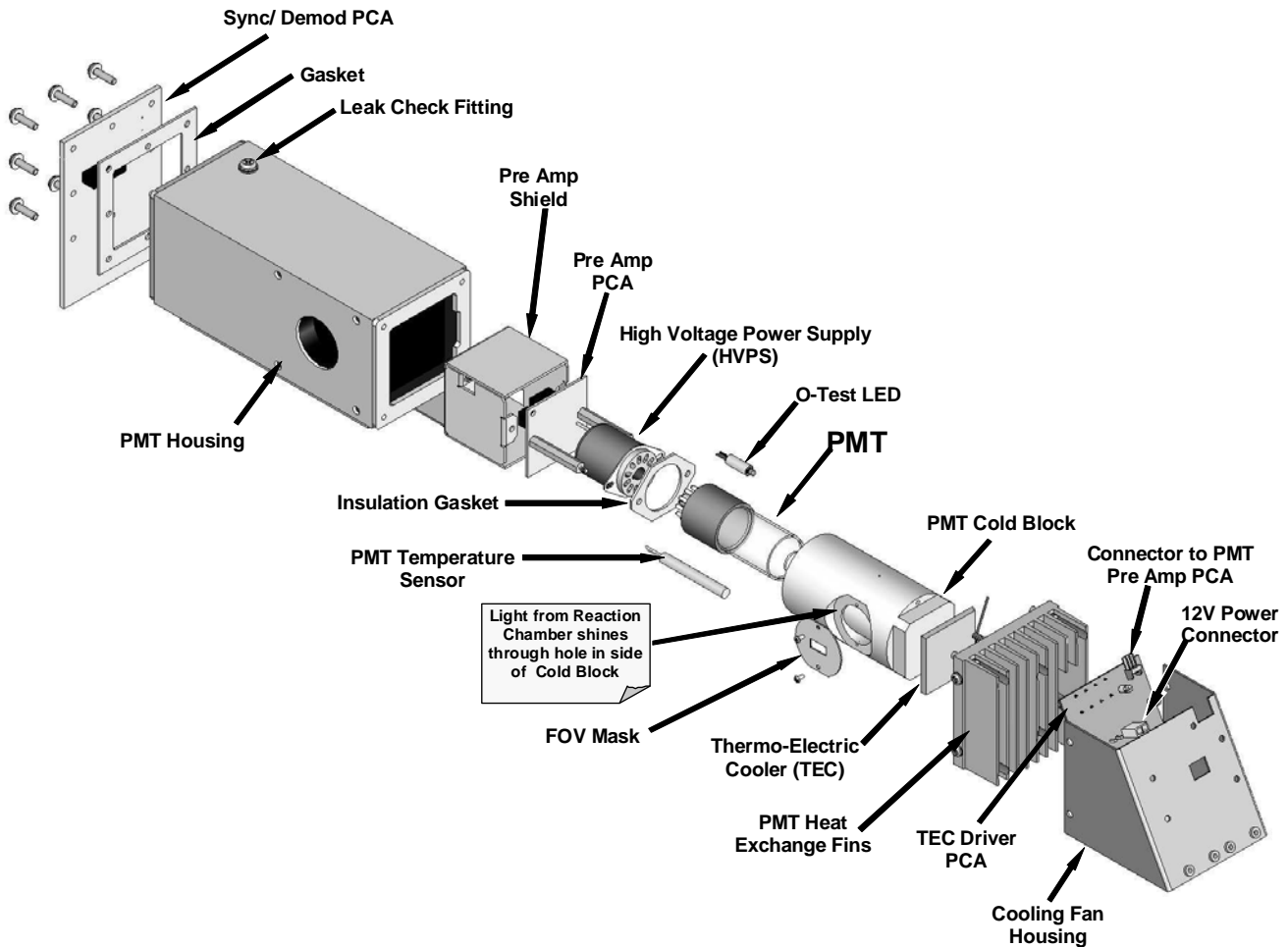

Figure 8-3: PMT Assembly - Exploded View

1. Power down the analyzer, disconnect the power cord, remove the cover and disconnect all pneumatic and electrical connections from the sensor assembly.
2. Remove the entire sensor module assembly from the analyzer.
3. Remove the fluorescence cell assembly.
4. Remove the two connectors on the Sync Demod board.
5. Remove the Sync Demod Board (6 screws with plastic washers). Disconnect the electrical connector that leads to the preamp board further inside the housing.
6. Remove all of the desiccant bags inside the PMT housing.
7. Along with the plate, slide out the OPTIC TEST LED and the thermistor that measures the PMT temperature.
 - The thermistor will be coated with a white, thermal conducting paste. Do not contaminate the inside of the housing or the PMT tube with this grease.

8. Unscrew the PMT assembly. It is held to the cold block by two plastic screws.
 - Because the threads of the plastic screws are easily damaged it is highly recommended to use new screws when reassembling the unit.
9. Carefully take out the assembly consisting of the HVPS, the gasket, preamp assembly and the PMT.
10. Change the PMT or the HVPS or both, clean the PMT glass tube with a clean, anti-static wipe and do not touch it after cleaning.
11. If the cold block or TEC is to be changed, disconnect the TEC driver board from the preamplifier board:
 - a) Remove the cooler fan duct (4 screws on its side) including the driver board.
 - b) Disconnect the driver board from the TEC and set the sub-assembly aside.
 - c) Remove the end plate with the cooling fins (4 screws) and slide out the PMT cold block assembly, which contains the TEC.
 - d) Unscrew the TEC from the cooling fins and the cold block and replace it with a new unit.
12. Re-assemble the TEC subassembly in reverse order.

ATTENTION**COULD DAMAGE INSTRUMENT AND VOID WARRANTY**

The thermo-electric cooler needs to be mounted flat to the heat sink. If there is any significant gap, the TEC might burn out. Make sure to apply heat sink paste before mounting it and tighten the screws evenly and cross-wise.

- a) Make sure to use thermal pads (HW-405) between the TEC and the cooling fins as well as between the TEC and the cold block.
 - b) Align the side opening in the cold block with the hole in the PMT housing where the sample Chamber attaches.
 - c) Evenly tighten the long mounting screws for good thermal conductivity.
13. Re-insert the TEC subassembly.
 - Make sure that the O-ring is placed properly and the assembly is tightened evenly.
 14. Insert the LED and thermistor into the cold block.
 15. Re-insert the PMT/HVPS subassembly.
 - Don't forget the gasket between HVPS and PMT.
 - Use new plastic screws to mount the PMT assembly on the PMT cold block.
 16. Insert the new desiccant bags.
 17. Reconnect the cable from the preamp board to the back of the Sync Demod board then carefully reattach the Sync Demod board to the housing.
 - Make sure that the gasket is between the back of the board and the front of the PMT housing.
 - Be sure to tighten these screws evenly,
 18. Reconnect the cables and the reaction cell.

19. Replace the sensor assembly into the chassis and fasten with four screws and washers.
20. Reconnect all electrical and pneumatic connections, leak check the system and power up the analyzer.
 - Verify the basic operation of the analyzer using the ETEST and OTEST features (see Section 5.9.4 & 5.9.5 of the T100 Manual) or by measuring calibrated zero and span gases.
21. Perform a PMT Hardware calibration (see Section 8.3.4 of this addendum).
22. Perform a zero point and span calibration (See Section 9 of the T100 Manual - P/N 06807).

8.3.4 T100U PMT HARDWARE CALIBRATION (FACTORY CAL)

This procedure supersedes the one contained in the T100 Manual.

The sensor module hardware calibration adjusts the slope of the PMT output when the Instruments slope and offset values are outside of the acceptable range and all other more obvious causes for this problem have been eliminated. Because the PMT HV is remotely controlled and there is no PMT preamp gain adjust, this procedure is done automatically through the analyzer software.

1. Set the instrument reporting range to **SNGL** & 500 ppb (see Section 5.4.3 of the T100 Manual)
2. Perform a full zero–point calibration using zero air (see Section 9 of the T100 Manual).
3. Let the instrument stabilize by allowing it to run for one hour.
4. Adjust the UV Lamp. (See Section 8.3.1.1 of this addendum)
5. Perform a **LAMP CALIBRATION** procedure (see Section 5.9.6 of the T100 Manual).
6. Feed 400 ppb span gas into the analyzer.
7. Wait approximately 30-60 minutes (or until the stability reads ≤ 0.1 ppb), then under the DIAG menu select PMT CALIBRATION.
8. Either press **ENTR** if you are using 400 ppb or change the concentration value to what is appropriate and then press **ENTR**.
9. Select the range that you wish to setup (low or high).
10. Wait two to three minutes until you get a message that indicates the HV has been adjusted successfully.

IMPORTANT

IMPACT ON READINGS OR DATA

If a reporting range other than 500 ppb is used in this procedure:

Use a span gas equal to 80% of the reporting range and adjust the PMT to a target NORM PMT value of twice the ppb value of the span gas.

EXAMPLE - If the reporting range is 800 ppb then set the target concentration to 640 ppb for this procedure.

11. Wait until the **STABIL** value is ≤ 0.1 ppb.

12. Scroll to the NORM PMT value and verify that it is approximately twice the ppb value of the span gas.
13. Perform a zero / span calibration.
14. Check the slope and offset values and compare them to the values in Table 9-5 of the T100 Manual.
15. Steps 7 - 14 may have to be performed more than once in order to compensate for any over/undershooting of the PMT reading based on the adjusted HVPS drive voltage. Best results occur after performing the PMT calibration (steps 7 - 14) at least two consecutive times.

8.4 TECHNICAL ASSISTANCE

If this addendum and its trouble-shooting / repair sections do not solve your problems, technical assistance may be obtained from:

Teledyne Instruments
Advanced Pollution Instrumentation Division
(TAPI)
Customer Service
9480 Carroll Park Drive
San Diego, California 92121-5201USA

Toll-free Phone: 800-324-5190

Phone: 858-657-9800

Fax: 858-657-9816

Email: API-CustomerService@Teledyne.com

Website: <http://www.Teledyne-API.com>

Before you contact Teledyne Instruments' Customer service, fill out the problem report form in Appendix C, which is also available online for electronic submission at <http://www.Teledyne-API.com/forms/p-fmapicom.asp>.

This page intentionally left blank.

9. PRINCIPLES OF OPERATION

The T100U is a modified T100. The primary differences are the way in which the PMT and UV reference signals are acquired and processed. The T100U has no shutter but rather employs synchronous demodulation to capture the dark and light PMT and UV reference signals several times per second. A printed circuit board, the Sync Demodulator, attached to the end of the PMT housing, on the sensor assembly, includes circuitry that digitizes the PMT and UV reference signals and synchronizes the operation of the UV source with these measurements. This method of signal processing minimizes the error that changing offsets could make in an instrument that is designed to operate near its detection limit.

9.1 ELECTRONIC OPERATION

The following information is in addition to that contained in Section 13.5.2 of the T100 Manual.

9.1.1 SENSOR MODULE

At the heart of the T100U's signal processing, illustrated in **Error! Reference source not found.** below, is the Synchronous Demodulator PCA (Sync Demod board). The PCA is attached to the end of the PMT housing and serves to seal the end of the PMT housing. The sync demodulator controls the operation of the UV Lamp driver, digitizes the analog output signals from the PMT UV reference detector and PMT temperature sensor, controls the PMT cooler (thermo-electric cooler, TEC), controls the PMT HV via a local I2C bus, and communicates with the analyzer's CPU over the master I2C bus. Digitized and processed data from the UV reference and PMT are passed to the analyzer's CPU over the master I2C bus and data for control of the PMT HV control DAC is passed from the CPU to the DAC on the PMT preamp via the microcontroller on the Sync Demod board.

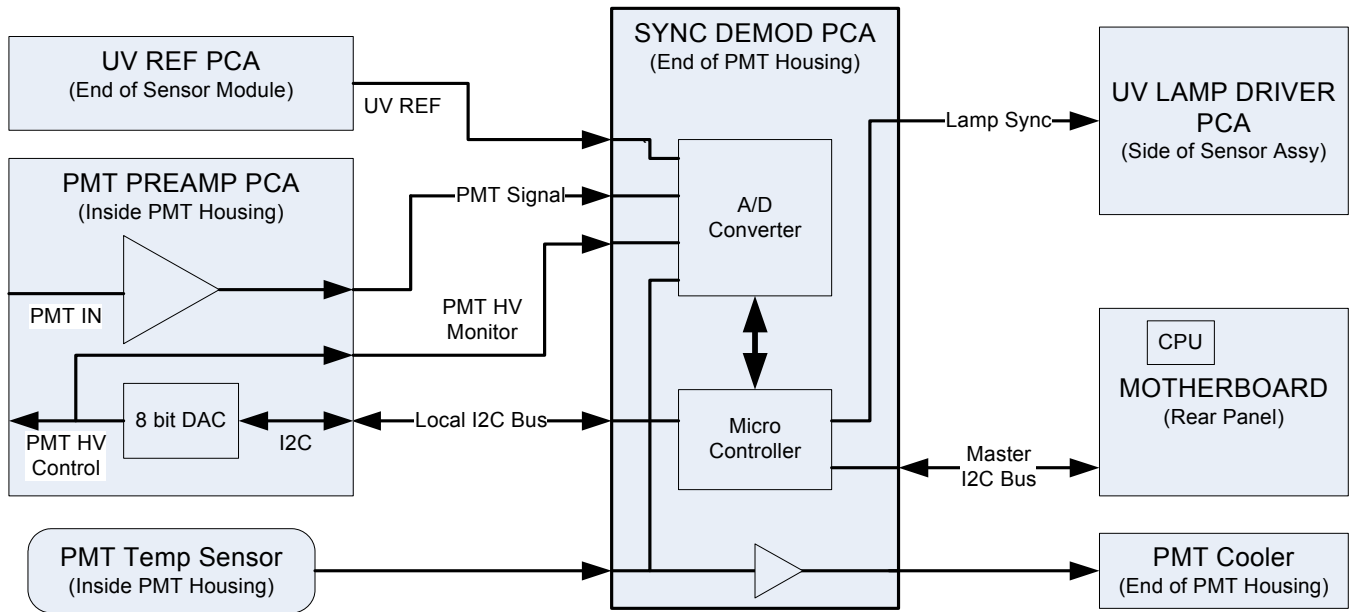

Figure 9-1: Sensor Block Diagram

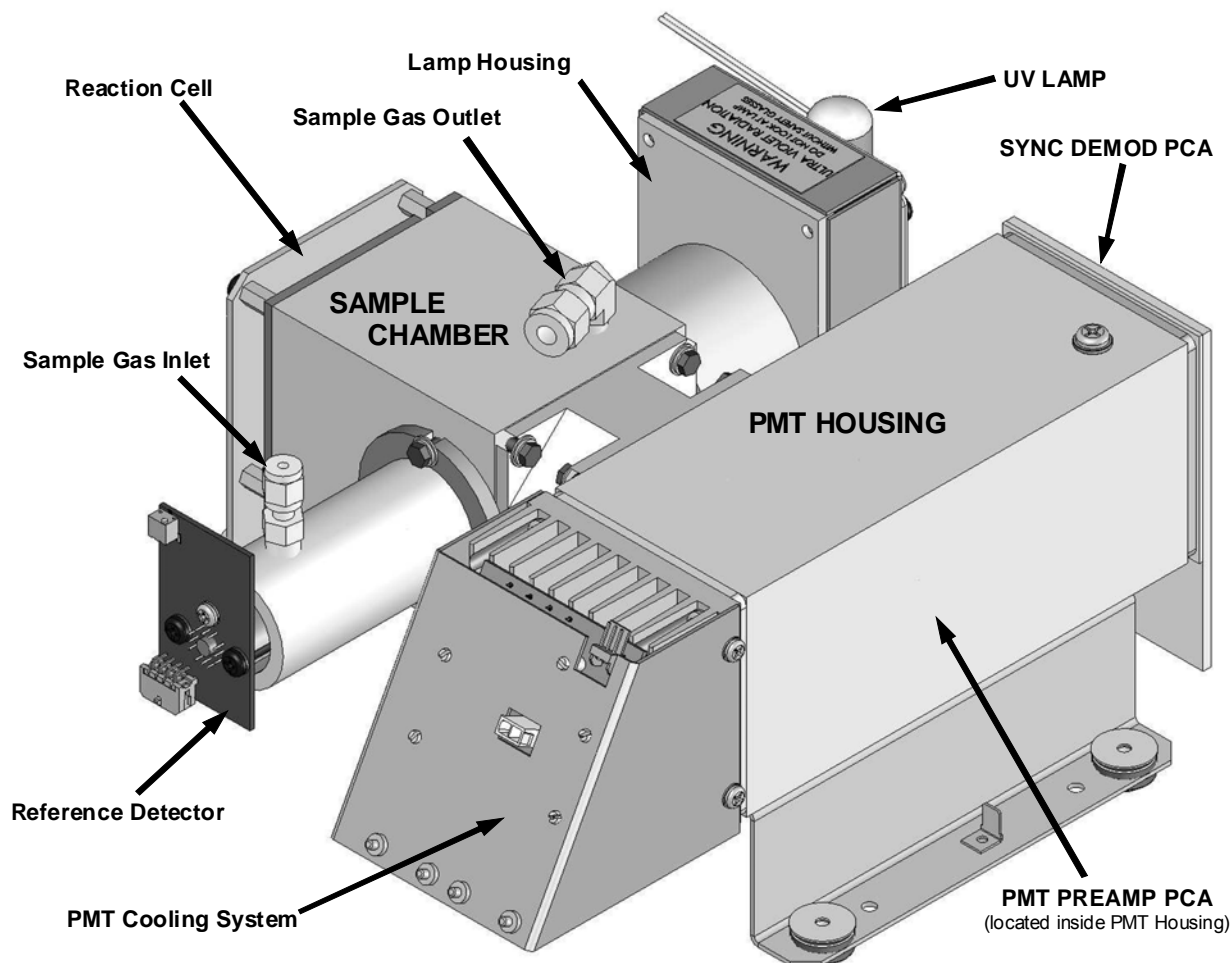

Figure 9-2: T100U Sensor Module Assembly

These components are divided into two significant subassemblies. The sample chamber and the PMT assembly.

Error! Reference source not found.Figure 9-3 shows an exploded view of the sample chamber assembly.

Figure 8-3 shows an exploded view of the PMT assembly.

9.1.1.1 Sample Chamber

The main electronic components of the sample chamber are the reference detector (see Section 13.1.4 of the T100 Manual); the UV Lamp (see Section 13.1.6 of the T100 Manual); and the sample chamber heating circuit,

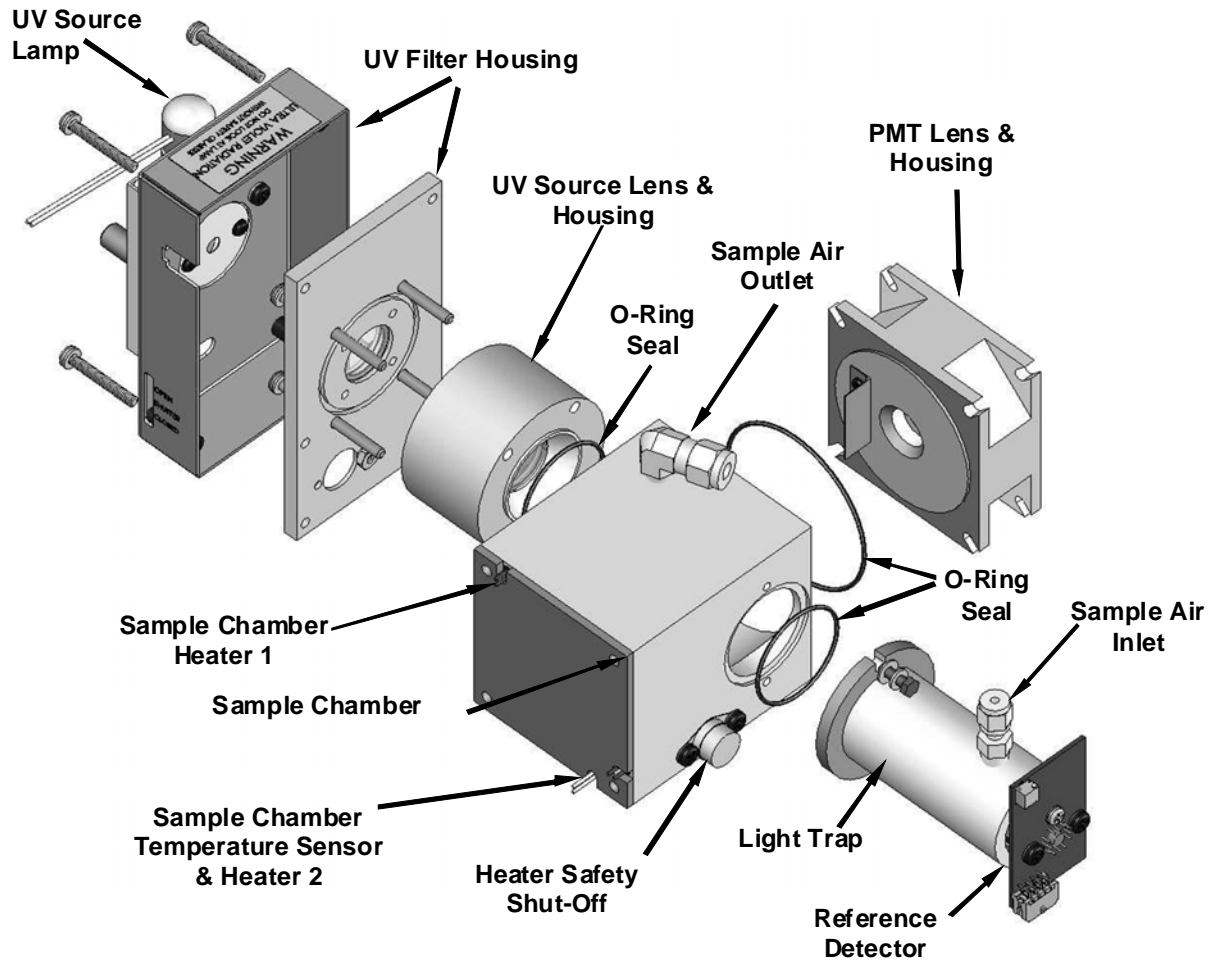

Figure 9-3: T100U Sample Chamber Exploded View

APPENDIX A - Version Specific Software Documentation

Appendix A of the T100 manual applies to the T100U.

This page intentionally left blank.

APPENDIX B - Spare Parts

Note

Use of replacement parts other than those supplied by Teledyne Advanced Pollution Instrumentation (TAPI) may result in non-compliance with European standard EN 61010-1.

Note

Due to the dynamic nature of part numbers, please refer to the TAPI Website at <http://www.teledyne-api.com> or call Customer Service at 800-324-5190 for more recent updates to part numbers.

This page intentionally left blank.

LIST, SPARE PARTS, T100U

(Reference: 068460000, 8/9/2011 10:21 AM)

PARTNUMBER	DESCRIPTION
045230200	PCA, RELAY CARD
046250000	ASSY, RXCELL HEATER/FUSE
046260000	ASSY, THERMISTOR, RXCELL (KB)
048830000	AKIT, EXP KIT, EXHAUST CLNSR, SILCA GEL
049310100	PCA,TEC DRIVER,PMT,(KB)
050610100	OPTION, 100-120V/60Hz (KB)
050610200	OPTION, 100-120V/50Hz (KB)
050610300	OPTION, 220-240V/50Hz, (KB)
050610400	OPTION, 220-240V/60Hz (KB)
050630200	PCA, REF DET w/OP20, DUAL OUT
051990000	ASSY, SCRUBBER, INLINE EXHAUST, DISPOS
052660000	ASSY, HEATER/THERM, IZS
054340000	PCA, PRECISION INT. PMT PREAMP
054650000	PCA, SYNC/DEMODO
055100200	ASSY, OPTION, PUMP, 240V *
055560000	ASSY, VALVE, VA59 W/DIODE, 5" LEADS
055920000	ASSY, SO2 SENSOR, ULTRA (KB)
056080000	ASSY, HVPS, PMT
058021100	PCA, MOTHERBD, GEN 5-ICOP
059200000	ASSY, UV LAMP, 10K, "ULTRA"
061930200	PCA, UV LAMP DRIVER, GEN-2, 48mA
066970000	PCA, INTRF. LCD TOUCH SCRN, F/P
067240000	CPU, PC-104, VSX-6154E, ICOP *(KB)
067300000	PCA, AUX-I/O BD, ETHERNET, ANALOG & USB
067300100	PCA, AUX-I/O BOARD, ETHERNET
067300200	PCA, AUX-I/O BOARD, ETHERNET & USB
067900000	LCD MODULE, W/TOUCHSCREEN(KB)
068230100	DOM, w/SOFTWARE, STD, T100U *
068810000	PCA, LVDS TRANSMITTER BOARD
069500000	PCA, SERIAL & VIDEO INTERFACE BOARD
072150000	ASSY. TOUCHSCREEN CONTROL MODULE
072770000	KIT, T100U MANUAL
CN0000073	POWER ENTRY, 120/60 (KB)
043570000	AKIT, EXPENDABLES
042410200	ASSY, PUMP, INT, SOX/O3/IR *
040030100	PCA, PRESS SENSORS (1X), w/FM4
040010000	ASSY, FAN REAR PANEL
037860000	ORING, TEFLON, RETAINING RING, 47MM (KB)
016300700	ASSY, SAMPLE FILTER, 47MM, ANG BKT
016290000	WINDOW, SAMPLE FILTER, 47MM (KB)
014750000	AKIT, EXP KIT, IZS
014400100	OPTION, ZERO AIR SCRUBBER
013570000	THERMISTOR HOUSING ASSY SOX/NOX(KB)

LIST, SPARE PARTS, T100U

(Reference: 068460000, 8/9/2011 10:21 AM)

PARTNUMBER	DESCRIPTION
013420000	ASSY, ROTARY SOLENOID
013400000	CD, PMT, SO2, (KB)
013390000	ASSY, KICKER
013210000	ASSY, VACUUM MANIFOLD
013140000	ASSY, COOLER FAN (NOX/SOX)
009690300	AKIT, TFE FLTR ELEM (FL19, 30=1) 47mm
009690200	AKIT, TFE FLTR ELEM (FL19,100=1) 47mm
005960000	AKIT, EXP, 6LBS ACT CHARCOAL (2 BT=1)
003290000	THERMISTOR, BASIC (VENDOR ASSY)(KB)
002720000	CD, FILTER, 330NM (KB)
002700000	CD, LENS, BI-CON (KB)
002690000	CD, LENS, PL-CON (KB)
000940800	CD, ORIFICE, .012 (NO PAINT)
000940100	CD, ORIFICE, .003 GREEN
CN0000458	PLUG, 12, MC 1.5/12-ST-3.81 (KB)
CN0000520	PLUG, 10, MC 1.5/10-ST-3.81 (KB)
FL0000001	FILTER, SS (KB)
FL0000003	FILTER, DFU (KB)
FM0000004	FLOWMETER (KB)
HW0000005	FOOT
HW0000020	SPRING
HW0000036	TFE TAPE, 1/4" (48 FT/ROLL)
HW0000453	SUPPORT, CIRCUIT BD, 3/16" ICOP
HW0000685	LATCH, MAGNETIC, FRONT PANEL
KIT000093	AKIT, REPLCMNT(3187)214NM FLTR (BF)
KIT000095	AKIT, REPLACEMENT COOLER
KIT000219	AKIT, 4-20MA CURRENT OUTPUT
KIT000253	ASSY & TEST, SPARE PS37
KIT000254	ASSY & TEST, SPARE PS38
OP0000031	WINDOW, QUARTZ, 1/2"DIA, .063" THICK (KB)
OR0000001	ORING, 2-006VT *(KB)
OR0000004	ORING, 2-029V
OR0000006	ORING, 2-038V
OR0000007	ORING, 2-039V
OR0000015	ORING, 2-117V
OR0000016	ORING, 2-120V
OR0000025	ORING, 2-133V
OR0000027	ORING, 2-042V
OR0000039	ORING, 2-012V
OR0000046	ORING, 2-019V
OR0000083	ORING, 105M, 1MM W X 5 MM ID, VITON
OR0000084	ORING, 2-020V
OR0000094	ORING, 2-228V, 50 DURO VITON(KB)

LIST, SPARE PARTS, T100U

(Reference: 068460000, 8/9/2011 10:21 AM)

PARTNUMBER	DESCRIPTION
PU0000022	REBUILD KIT, FOR PU20 & 04241 (KB)
RL0000015	RELAY, DPDT, (KB)
SW0000025	SWITCH, POWER, CIRC BREAK, VDE/CE *(KB)
SW0000059	PRESSURE SENSOR, 0-15 PSIA, ALL SEN
WR0000008	POWER CORD, 10A(KB)

RECOMMENDED SPARE PARTS STOCKING LEVELS
Model 100EU

(Reference: 05946A)		UNITS				
PART NO	DESCRIPTION	1	2-5	6-10	11-20	21-30
000940800	Orifice, 12 Mil		1	2	4	4
002720000	Filter, 330 NM			1	2	3
013140000	Cooler Fan	1	1	2	4	4
013400000	PMT, SO2				1	1
014080100	Assy, HVPS, NOX/SOX					1
014610000	Kit, Replacement Cooler					1
040010000	Assy, Fan, Rear Panel, E Series	1	1	2	4	4
040030100	PCA, Press Sensors (1X), Flow, E Series		1	2	4	4
041710000	CPU, Configuration E Series				1	1
042410400	Assy, Pump, Internal, E Series, 115/240V					1
042580000	PCA, Keyboard				1	1
045230200	PCA, Relay Board w/Diode Protection			1	1	2
050630200	PCA, M100EU UV Ref Det, Dual Out				1	2
054340000	PCA, Precision INT, PMT Preamp				1	1
054650000	PCA, Sync/Demod				1	1
054710000	Assy, UV Lamp, M100E		1	2	4	4
055120200	PCA, Bursting UV Driver, M100EU		1	1	2	2
057020100	PCA, Motherboard, E Series, GEN 4				1	2
DS0000025	Display				1	1

IZS/ZS Option					
055560000	ASSY, VALVE, VA59 W/DIODE, E-SERIES		1	2	4

Appendix C
Warranty/Repair Questionnaire
T100U, M100EU
(05930B DCN5798)



TELEDYNE
ADVANCED POLLUTION INSTRUMENTATION
A Teledyne Technologies Company

CUSTOMER: _____ PHONE: _____

CONTACT NAME: _____ FAX NO. _____

SITE ADDRESS: _____

MODEL SERIAL NO.: _____ FIRMWARE REVISION: _____

1. ARE THERE ANY FAILURE MESSAGES? _____

2. PLEASE COMPLETE THE FOLLOWING TABLE: (NOTE: **DEPENDING ON OPTIONS INSTALLED, NOT ALL TEST PARAMETERS BELOW WILL BE AVAILABLE IN YOUR INSTRUMENT**)

Parameter *IF OPTION IS INSTALLED	Recorded Value	Acceptable Value
RANGE	PPB/PPM	0-500 PPB Standard
STABIL	PPB	≤0.3 PPB with ZERO AIR
STABIL2	PPB	≤ 1 PPB with ZERO AIR
PRESS	IN-HG-A	AMBIENT (- 2) IN-HG-A
SAMPLE FLOW	cm ³ /MIN	650 ± 10%
PMT SIGNAL WITH ZERO AIR	mV	-20 TO 150 mV
PMT SIGNAL AT SPAN GAS CONC	mV PPB/PPM	0-5000 mV 0-20000 PPB
NORM PMT AT SPAN GAS CONC	mV PPB/PPM	0-5000 mV 0-20000 PPB
UV LAMP	mV	2000 TO 4000 mV
UV STAB	mV	< 15mV
LAMP RATIO	mV	30 TO 120%
STR. LGT	PPB	≤ 100 PPB/ ZERO AIR
DARK PMT	mV	200-325
DARK LAMP	mV	-50 TO 200 mV
SLOPE		1.0 ± 0.5
OFFSET	mV	< 250 mV
HVPS	V	≈ 400 – 800
RCELL TEMP	°C	50°C ± 1
BOX TEMP	°C	AMBIENT ± 5
PMT TEMP	°C	9.5°C ± 2° CONSTANT
IZS TEMP*	°C	50°C ± 1
ETEST	mV	2000 mV ± 1000
OTEST	mV	2000 mV ± 1000
Values are in the Signal I/O		
REF 4096 MV	mV	4096mv±2mv and Must be Stable
REF_GND	mV	0± 0.5 and Must be Stable

TELEDYNE API CUSTOMER SERVICE

Email: api-customerservice@teledyne.com

PHONE: (858) 657-9800 TOLL FREE: (800) 324-5190 FAX: (858) 657-9816



3. WHAT IS THE SAMPLE FLOW & SAMPLE PRESSURE W/SAMPLE INLET ON REAR OF MACHINE CAPPED?

SAMPLE FLOW - _____ CC SAMPLE PRESS - _____ IN-HG-A

4. WHAT ARE THE FAILURE SYMPTOMS? _____

5. IF POSSIBLE, PLEASE INCLUDE A PORTION OF A STRIP CHART PERTAINING TO THE PROBLEM. CIRCLE PERTINENT DATA.

THANK YOU FOR PROVIDING THIS INFORMATION. YOUR ASSISTANCE ENABLES TELEDYNE API TO RESPOND FASTER TO THE PROBLEM THAT YOU ARE ENCOUNTERING.

TELEDYNE API CUSTOMER SERVICE

Email: api-customerservice@teledyne.com

PHONE: (858) 657-9800 TOLL FREE: (800) 324-5190 FAX: (858) 657-9816

APPENDIX D – Electronic Schematics

Contains schematics for the T100U addendum; other schematics are located in Appednix D of the T100 Operators Manual (07268).

This page intentionally left blank.

Interconnect List, T100U

(Reference 0736201Rev 01)

Revision	Description						Checked	Date	DCN
01	Initial Release						KV	11/10/10	
Cable PN	Signal	Assembly	FROM			TO			
			PN	J/P	Pin	Assembly	PN	J/P	Pin
0364901	CBL ASSY, AC POWER								
	AC Line	Power Entry	CN0000073		L	Power Switch	SW0000025	L	
	AC Neutral	Power Entry	CN0000073		N	Power Switch	SW0000025	N	
	Power Grnd	Power Entry	CN0000073			Shield			
	Power Grnd	Power Entry	CN0000073			Chassis			
	AC Line Switched	Power Switch	SW0000025		L	PS2 (+12)	068020000	SK2 1	
	AC Neu Switched	Power Switch	SW0000025		N	PS2 (+12)	068020000	SK2 3	
	Power Grnd	Power Entry	CN0000073			PS2 (+12)	068020000	SK2 2	
	AC Line Switched	Power Switch	SW0000051		L	PS1 (+5, ±15)	068010000	SK2 1	
	AC Neu Switched	Power Switch	SW0000025		N	PS1 (+5, ±15)	068010000	SK2 3	
	Power Grnd	Power Entry	CN0000073			PS1 (+5, ±15)	068010000	SK2 2	
	AC Line Switched	Power Switch	SW0000025		L	Relay PCA	045230100	J1 1	
	AC Neu Switched	Power Switch	SW0000025		N	Relay PCA	045230100	J1 3	
	Power Grnd	Power Entry	CN0000073			Relay PCA	045230100	J1 2	
03829	CBL ASSY, DC POWER TO MOTHERBOARD								
	DGND	Relay PCA	045230100	J7	1	Motherboard	058021100	J15 1	
	+5V	Relay PCA	045230100	J7	2	Motherboard	058021100	J15 2	
	AGND	Relay PCA	045230100	J7	3	Motherboard	058021100	J15 3	
	+15V	Relay PCA	045230100	J7	4	Motherboard	058021100	J15 4	
	AGND	Relay PCA	045230100	J7	5	Motherboard	058021100	J15 5	
	-15V	Relay PCA	045230100	J7	6	Motherboard	058021100	J15 6	
	+12V RET	Relay PCA	045230100	J7	7	Motherboard	058021100	J15 7	
	+12V	Relay PCA	045230100	J7	8	Motherboard	058021100	J15 8	
	Chassis Gnd	Relay PCA	045230100	J7	10	Motherboard	058021100	J15 9	
04023	CBL, I2C, RELAY BOARD TO MOTHERBOARD								
	I2C Serial Clock	Motherboard	058021100	P107	3	Relay PCA	045230100	P3 1	
	I2C Serial Data	Motherboard	058021100	P107	5	Relay PCA	045230100	P3 2	
	I2C Reset	Motherboard	058021100	P107	2	Relay PCA	045230100	P3 4	
	I2C Shield	Motherboard	058021100	P107	6	Relay PCA	045230100	P3 5	
0402602	CBL, IZS HTR/TH, RXCELL & OB TH								
	RTHA	Motherboard	058021100	P27	7	RX Cell Thermistor	046260000	2	
	RTHB	Motherboard	058021100	P27	14	RX Cell Thermistor	046260000	1	
	IZTA	Motherboard	058021100	P27	6	IZS Therm/Htr	052660000	2	
	IZTB	Motherboard	058021100	P27	13	IZS Therm/Htr	052660000	3	
	IZS-L	Relay PCA	045230100	P18	1	IZS Therm/Htr	052660000	4	
	IZS-N	Relay PCA	045230100	P18	2	IZS Therm/Htr	052660000	1	
	GND	Relay PCA	045230100	P18	11	Shield			
	O2-L	Relay PCA	045230100	P18	6	O2 Sensor Therm/Htr	043420000	4	
	O2-N	Relay PCA	045230100	P18	7	O2 Sensor Therm/Htr	043420000	2	
	TS3	Relay PCA	045230100	P18	3	Relay PCA	045230100	P18 4	
	TS4	Relay PCA	045230100	P18	8	Relay PCA	045230100	P18 9	
	N/C	Relay PCA	045230100	P18	12	Shield			
	O2TA	Motherboard	058021100	P27	4	O2 Sensor Therm/Htr	043420000	3	
	O2TB	Motherboard	058021100	P27	11	O2 Sensor Therm/Htr	043420000	1	
0402701	CBL, RX CELL HEATERS								
	RH1B	Relay PCA	045230100	P2	1	RX Cell Heaters	046250000	4	
	RH2B	Relay PCA	045230100	P2	1	RX Cell Heaters	046250000	6	
	RH1A	Relay PCA	045230100	P2	2	RX Cell Heaters	046250000	3	
	RTS1	Relay PCA	045230100	P2	3	RX Cell Heaters	046250000	1	
	RTS2	Relay PCA	045230100	P2	4	RX Cell Heaters	046250000	2	
	RH2A	Relay PCA	045230100	P2	5	RX Cell Heaters	046250000	5	
		Relay PCA	045230100	P2	13	Relay PCA	045230100	P2 14	
		Relay PCA	045230100	P2	8	Relay PCA	045230100	P2 9	
04105	CBL, KEYBD TO MTHBRD								
	Kbd Interrupt	LCD Interface PCA	066970000	J1	7	Motherboard	058021100	J106 1	
	DGND	LCD Interface PCA	066970000	J1	2	Motherboard	058021100	J106 8	
	SDA	LCD Interface PCA	066970000	J1	5	Motherboard	058021100	J106 2	
	SCL	LCD Interface PCA	066970000	J1	6	Motherboard	058021100	J106 6	
	Shld	LCD Interface PCA	066970000	J1	10	Motherboard	058021100	J106 5	
04176	CBL, DC POWER TO RELAY BOARD								
	DGND	Relay PCA	045230100	P8	1	Power Supply Triple	068010000	J1 3	
	+5V	Relay PCA	045230100	P8	2	Power Supply Triple	068010000	J1 1	
	+15V	Relay PCA	045230100	P8	4	Power Supply Triple	068010000	J1 6	
	AGND	Relay PCA	045230100	P8	5	Power Supply Triple	068010000	J1 4	
	-15V	Relay PCA	045230100	P8	6	Power Supply Triple	068010000	J1 5	
	+12V RET	Relay PCA	045230100	P8	7	Power Supply Single	068020000	J1 3	
	+12V	Relay PCA	045230100	P8	8	Power Supply Single	068020000	J1 1	
04437	CBL, PREAMPLIFIER TO TEC								
	Preamp TEC drive VREF	Preamp PCA	041800400	J1	1	TEC PCA	049310100	J3 1	
	Preamp TEC drive CTRL	Preamp PCA	041800400	J1	2	TEC PCA	049310100	J3 2	
	Preamp TEC drive AGND	Preamp PCA	041800400	J1	3	TEC PCA	049310100	J3 3	

Interconnect List, T100U

(Reference 0736201Rev 01)

Cable PN	Signal	FROM				TO			
		Assembly	PN	J/P	Pin	Assembly	PN	J/P	Pin
044880100	CBL, MAIN HARNESS								
	AGND	Relay PCA	045230100	P5	1	O2 Sensor	049210000	P1	5
	-V15	Relay PCA	045230100	P5	2	O2 Sensor	049210000	P1	6
		Relay PCA	045230100	P5	3	UV Ref PCA	050630100	P1	4
	O2 SIGNAL-	Motherboard	058021100	P109	7	O2 Sensor	049210000	P1	9
	O2 SIGNAL+	Motherboard	058021100	P109	1	O2 Sensor	049210000	P1	10
		Motherboard	058021100	P109	10	Shield			
	CH2	Motherboard	058021100	P109	2	UV Ref PCA	050630100	P1	5
	+15V	Relay PCA	045230100	P10	4	UV Ref PCA	050630100	P1	2
	-15V	Relay PCA	045230100	P10	6	UV Ref PCA	050630100	P1	3
	TEC +12V RET	Relay PCA	045230100	P10	7	TEC PCA	049310100		2
	TEC +12V	Relay PCA	045230100	P10	8	TEC PCA	049310100		1
	DISP RET	Relay PCA	045230100	P10	1	LCD Interface PCA	066970000	P14	8
	+5 DISP	Relay PCA	045230100	P10	2	LCD Interface PCA	066970000	P14	1
	EGND	Shield				LCD Interface PCA	066970000	P14	4
	SDA	Sync Demod	054650000	P1	5	LCD Interface PCA	066970000	P14	5
	SCL	Sync Demod	054650000	P1	3	LCD Interface PCA	066970000	P14	6
	DGND	Relay PCA	045230100	P11	1	LCD Interface PCA	066970000	P14	2
	VCC	Relay PCA	045230100	P11	2	LCD Interface PCA	066970000	P14	3
	+12RET	Relay PCA	045230100	P11	7	Fan	040010000		1
	+12V	Relay PCA	045230100	P11	8	Fan	040010000		2
	AGND	Relay PCA	045230100	P11	3	Flow Module PCA	040030100	P1	3
	+15V	Relay PCA	045230100	P11	4	Flow Module PCA	040030100	P1	6
	PRESS SIGNAL 1	Motherboard	058021100	P110	6	Flow Module PCA	040030100	P1	2
	PRESS SIGNAL 2	Motherboard	058021100	P110	5	Flow Module PCA	040030100	P1	4
	FLOW SIGNAL 1	Motherboard	058021100	P110	4	Flow Module PCA	040030100	P1	5
	FLOW SIGNAL 2	Motherboard	058021100	P110	3	Flow Module PCA	040030100	P1	1
	SHIELD	Motherboard	058021100	P110	12	Shield			
	SHIELD	Motherboard	058021100	P110	9	Shield			
	TC SIGNAL 1	Motherboard	058021100	P110	2	Relay PCA	045230100	P17	1
	TC 1 SIGNAL DGND	Motherboard	058021100	P110	8	Relay PCA	045230100	P17	2
	TC SIGNAL 2	Motherboard	058021100	P110	1	Relay PCA	045230100	P17	3
	TC 2 SIGNAL DGND	Motherboard	058021100	P110	7	Relay PCA	045230100	P17	4
		UV Ref PCA	050630100	P1	1	Sync Demod	054650000	P3	6
	AGND	Shield				Sync Demod	054650000	P3	9
	AGND	Shield				Sync Demod	054650000	P3	7
	DGND	Relay PCA	045230100	P9	1	Sync Demod	054650000	P3	1
	VCC	Relay PCA	045230100	P9	2	Sync Demod	054650000	P3	2
	+15V	Relay PCA	045230100	P9	4	Sync Demod	054650000	P3	3
	AGND	Relay PCA	045230100	P9	5	Sync Demod	054650000	P3	4
	-15V	Relay PCA	045230100	P9	6	Sync Demod	054650000	P3	5
	+12RET	Relay PCA	045230100	P9	7	Lamp Driver PCA	061930000	P1	2
	+12V	Relay PCA	045230100	P9	8	Lamp Driver PCA	061930000	P1	1
04562	CBL, Z/S IZS VALVES								
	Sample Valve +12V	Relay PCA	045230100	P4	1	SMP/CAL	055560000		1
	Sample Valve +12V RET	Relay PCA	045230100	P4	2	SMP/CAL	055560000		2
	Zero/Span valve +12V	Relay PCA	045230100	P4	3	ZS/Hi S	055560100		1
	Zero/Span valve +12V RE	Relay PCA	045230100	P4	4	ZS/Hi S	055560100		2
	Low Span Valve +12V	Relay PCA	045230100	P4	5	Lo Span	055560100		1
	Low Span Valve +12V RET	Relay PCA	045230100	P4	6	Lo Span	055560100		2
	AutoZero Valve +12V	Relay PCA	045230100	P4	7	Zero	055560000		1
	AutoZero Valve +12V RET	Relay PCA	045230100	P4	8	Zero	055560000		2
04671	CBL, MOTHERBOARD TO XMITTER BD (MULTIDROP OPTION)								
	GND	Motherboard	058021100	P12	2	Xmitter bd w/Multidrop	069500000	J4	2
	RX0	Motherboard	058021100	P12	14	Xmitter bd w/Multidrop	069500000	J4	14
	RTS0	Motherboard	058021100	P12	13	Xmitter bd w/Multidrop	069500000	J4	13
	TX0	Motherboard	058021100	P12	12	Xmitter bd w/Multidrop	069500000	J4	12
	CTS0	Motherboard	058021100	P12	11	Xmitter bd w/Multidrop	069500000	J4	11
	RS-GND0	Motherboard	058021100	P12	10	Xmitter bd w/Multidrop	069500000	J4	10
	RTS1	Motherboard	058021100	P12	8	Xmitter bd w/Multidrop	069500000	J4	8
	CTS1/485-	Motherboard	058021100	P12	6	Xmitter bd w/Multidrop	069500000	J4	6
	RX1	Motherboard	058021100	P12	9	Xmitter bd w/Multidrop	069500000	J4	9
	TX1/485+	Motherboard	058021100	P12	7	Xmitter bd w/Multidrop	069500000	J4	7
	RS-GND1	Motherboard	058021100	P12	5	Xmitter bd w/Multidrop	069500000	J4	5
	RX1	Motherboard	058021100	P12	9	Xmitter bd w/Multidrop	069500000	J4	9
	TX1/485+	Motherboard	058021100	P12	7	Xmitter bd w/Multidrop	069500000	J4	7
	RS-GND1	Motherboard	058021100	P12	5	Xmitter bd w/Multidrop	069500000	J4	5

Interconnect List, T100U

(Reference 0736201Rev 01)

Cable PN	Signal	Assembly	FROM			TO					
			PN	J/P	Pin	Assembly	PN	J/P	Pin		
05675	CBL, UV LAMP CONTROL, M100EU	Sync/Demd	054650000	P4	1	UV Driver Board	061930200	Pigtail	2		
		Sync/Demd	054650000	P4	4	UV Driver Board	061930200	Pigtail	1		
06737	CBL, I2C to AUX I/O (ANALOG IN OPTION)	Motherboard	058021100	J106	1	Aux I/O PCA	067300000	J2	1		
		Motherboard	058021100	J106	2	Aux I/O PCA	067300000	J2	2		
		Motherboard	058021100	J106	3	Aux I/O PCA	067300000	J2	3		
		Motherboard	058021100	J106	4	Aux I/O PCA	067300000	J2	4		
		Motherboard	058021100	J106	5	Aux I/O PCA	067300000	J2	5		
		Motherboard	058021100	J106	6	Aux I/O PCA	067300000	J2	6		
		Motherboard	058021100	J106	8	Aux I/O PCA	067300000	J2	8		
06738	CBL, CPU COM to AUX I/O (USB OPTION)	CPU PCA	067240000	COM1	1	Aux I/O PCA	0673000 or -02	J3	1		
		CPU PCA	067240000	COM1	2	Aux I/O PCA	0673000 or -02	J3	2		
		CPU PCA	067240000	COM1	3	Aux I/O PCA	0673000 or -02	J3	3		
		CPU PCA	067240000	COM1	4	Aux I/O PCA	0673000 or -02	J3	4		
		CPU PCA	067240000	COM1	5	Aux I/O PCA	0673000 or -02	J3	5		
		CPU PCA	067240000	COM1	6	Aux I/O PCA	0673000 or -02	J3	6		
		CPU PCA	067240000	COM1	7	Aux I/O PCA	0673000 or -02	J3	7		
		CPU PCA	067240000	COM1	8	Aux I/O PCA	0673000 or -02	J3	8		
		CPU PCA	067240000	COM1	10	Aux I/O PCA	0673000 or -02	J3	10		
		06738	CBL, CPU COM to AUX I/O (MULTIDROP OPTION)	CPU PCA	067240000	COM1	1	Xmitter bd w/Multidrop	069500000	J3	1
				CPU PCA	067240000	COM1	2	Xmitter bd w/Multidrop	069500000	J3	2
CPU PCA	067240000			COM1	3	Xmitter bd w/Multidrop	069500000	J3	3		
CPU PCA	067240000			COM1	4	Xmitter bd w/Multidrop	069500000	J3	4		
CPU PCA	067240000			COM1	5	Xmitter bd w/Multidrop	069500000	J3	5		
CPU PCA	067240000			COM1	6	Xmitter bd w/Multidrop	069500000	J3	6		
CPU PCA	067240000			COM1	7	Xmitter bd w/Multidrop	069500000	J3	7		
CPU PCA	067240000			COM1	8	Xmitter bd w/Multidrop	069500000	J3	8		
CPU PCA	067240000			COM1	10	Xmitter bd w/Multidrop	069500000	J3	10		
06739	CBL, CPU ETHERNET TO AUX I/O			CPU PCA	067240000	LAN	1	Aux I/O PCA	06730XXXX	J2	1
				CPU PCA	067240000	LAN	2	Aux I/O PCA	06730XXXX	J2	2
		CPU PCA	067240000	LAN	3	Aux I/O PCA	06730XXXX	J2	3		
		CPU PCA	067240000	LAN	4	Aux I/O PCA	06730XXXX	J2	4		
		CPU PCA	067240000	LAN	5	Aux I/O PCA	06730XXXX	J2	5		
		CPU PCA	067240000	LAN	6	Aux I/O PCA	06730XXXX	J2	6		
		CPU PCA	067240000	LAN	7	Aux I/O PCA	06730XXXX	J2	7		
		CPU PCA	067240000	LAN	8	Aux I/O PCA	06730XXXX	J2	8		
		06741	CBL, CPU USB TO FRONT PANEL	CPU PCA	067240000	USB	8	LCD Interface PCA	066970000	J9	
CPU PCA	067240000			USB	6	LCD Interface PCA	066970000	J9			
CPU PCA	067240000			USB	4	LCD Interface PCA	066970000	J9			
CPU PCA	067240000			USB	2	LCD Interface PCA	066970000	J9			
06746	CBL, MB TO 06154 CPU			Motherboard	058021100	P12	2	Shield			
		Motherboard	058021100	P12	14	CPU PCA	067240000	COM1	1		
		Motherboard	058021100	P12	13	CPU PCA	067240000	COM1	8		
		Motherboard	058021100	P12	12	CPU PCA	067240000	COM1	4		
		Motherboard	058021100	P12	11	CPU PCA	067240000	COM1	7		
		Motherboard	058021100	P12	10	CPU PCA	067240000	COM1	6		
		Motherboard	058021100	P12	8	CPU PCA	067240000	COM2	8		
		Motherboard	058021100	P12	6	CPU PCA	067240000	COM2	7		
		Motherboard	058021100	P12	9	CPU PCA	067240000	COM2	1		
		Motherboard	058021100	P12	7	CPU PCA	067240000	COM2	4		
		Motherboard	058021100	P12	5	CPU PCA	067240000	COM2	6		
		Motherboard	058021100	P12	9	CPU PCA	067240000	485	1		
		Motherboard	058021100	P12	7	CPU PCA	067240000	485	2		
		Motherboard	058021100	P12	5	CPU PCA	067240000	485	3		
		06910	CBL, COOLER FAN	Relay PCA	045230100	P12	7	Cooler Fan	013140000		2
Relay PCA	045230100			P12	8	Cooler Fan	013140000		1		
WR256	CBL, XMITTER TO INTERFACE	LCD Interface PCA	066970000	J15		Transmitter PCA	068810000	J1			

This page intentionally left blank.

REVISIONS				
REV	DESCRIPTION	DATE	DCN	APPROVED
01	PROTOTYPE RELEASE	11/9/10		KV

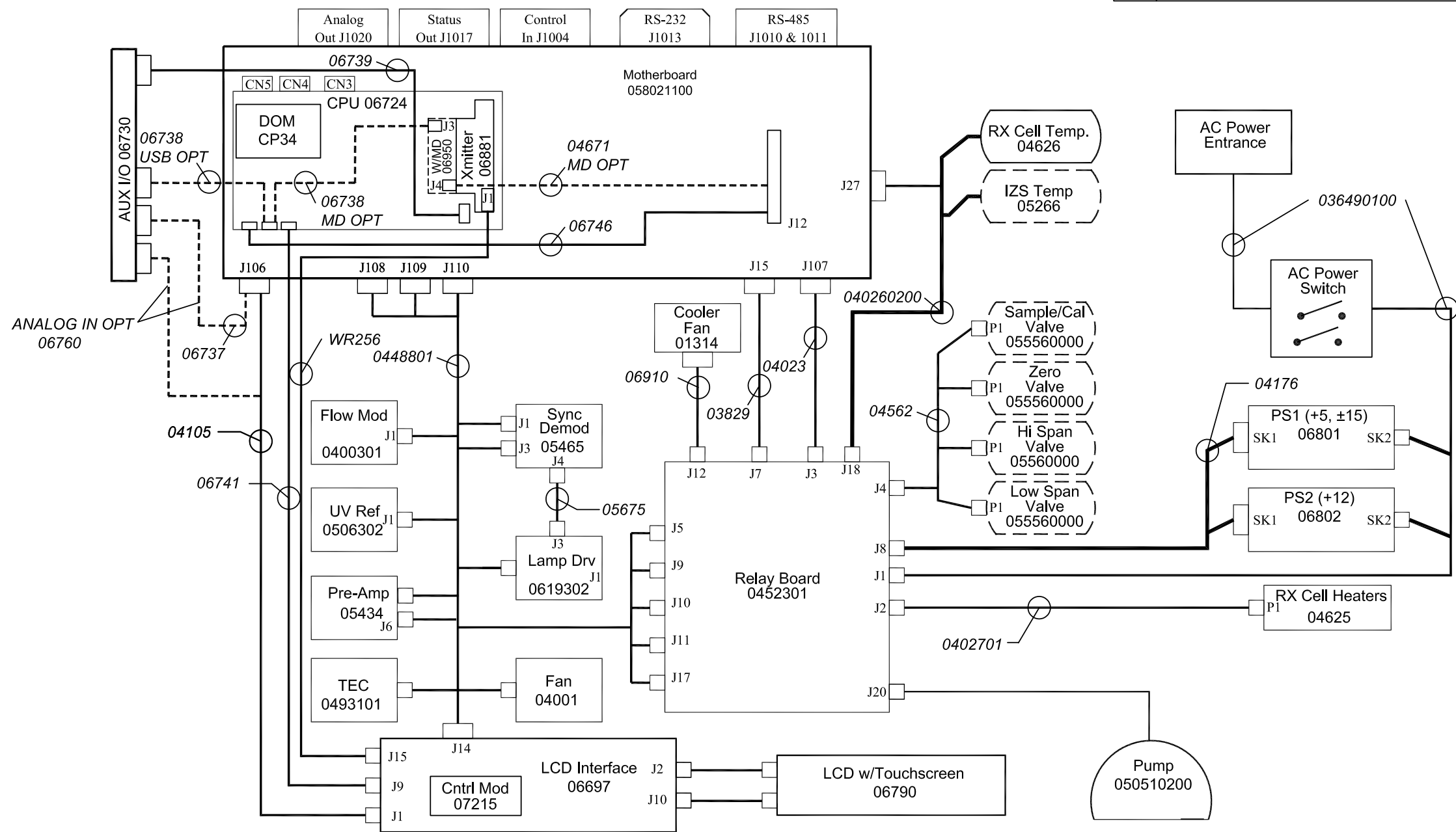

PRINTED DOCUMENTS ARE UNCONTROLLED

KEY:
 1. All part numbers in *Italic* identify cables that are referred to in the accompanying document 073620100.
 2. All items in Dashed boxes are optional.

The information hereon is the property of API and is submitted in strictest confidence for reference only. Unauthorized use by anyone for any other purposes is prohibited. This document or an information contained in it may not be duplicated without proper authorization.	UNLESS OTHERWISE SPECIFIED DIMENSIONS ARE IN INCHES TOLERANCES ARE: FRACTIONS ± 1/32 DECIMALS ± .03[0.76] ANGULAR ± 0° 30' DO NOT SCALE DRAWING		CONTRACT: NA APPROVALS: KV DATE: 11/10		TELEDYNE Advanced Pollution Instrumentation A Teledyne Technologies Company TITLE INTERCONNECT DRAWING T100U SIZE B CAGE CODE NO. 1JZF4 DWG. NO. 07362 REV 01 SCALE DNS FILE 07362 SHEET 1 OF 1
	TREATMENT NA		DRAWN KV		
	FINISH NA		CHECK		
	SIMILAR TO		CCB		
 THIRD ANGLE PROJECTION	 SIMILAR TO		ISSUED		

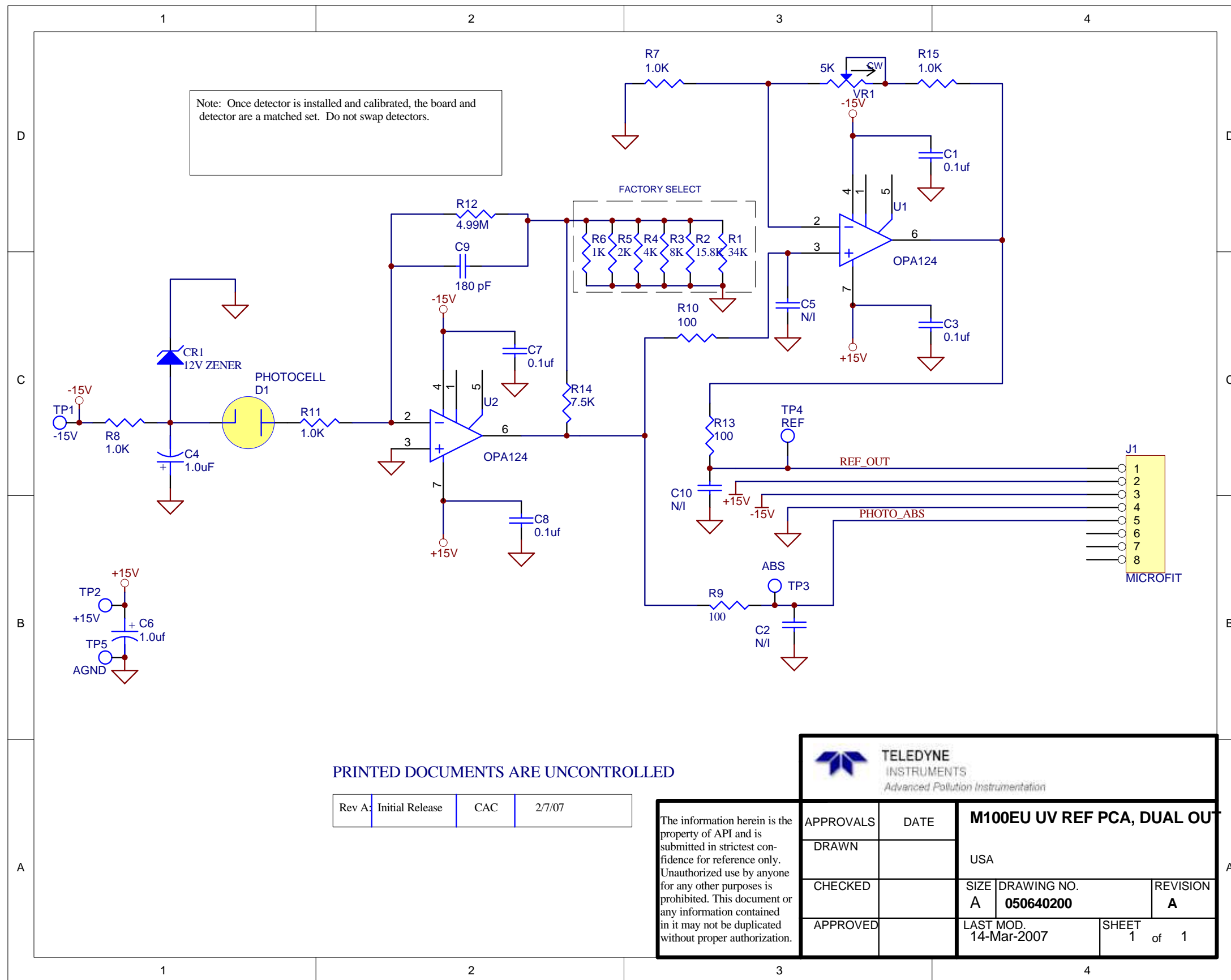

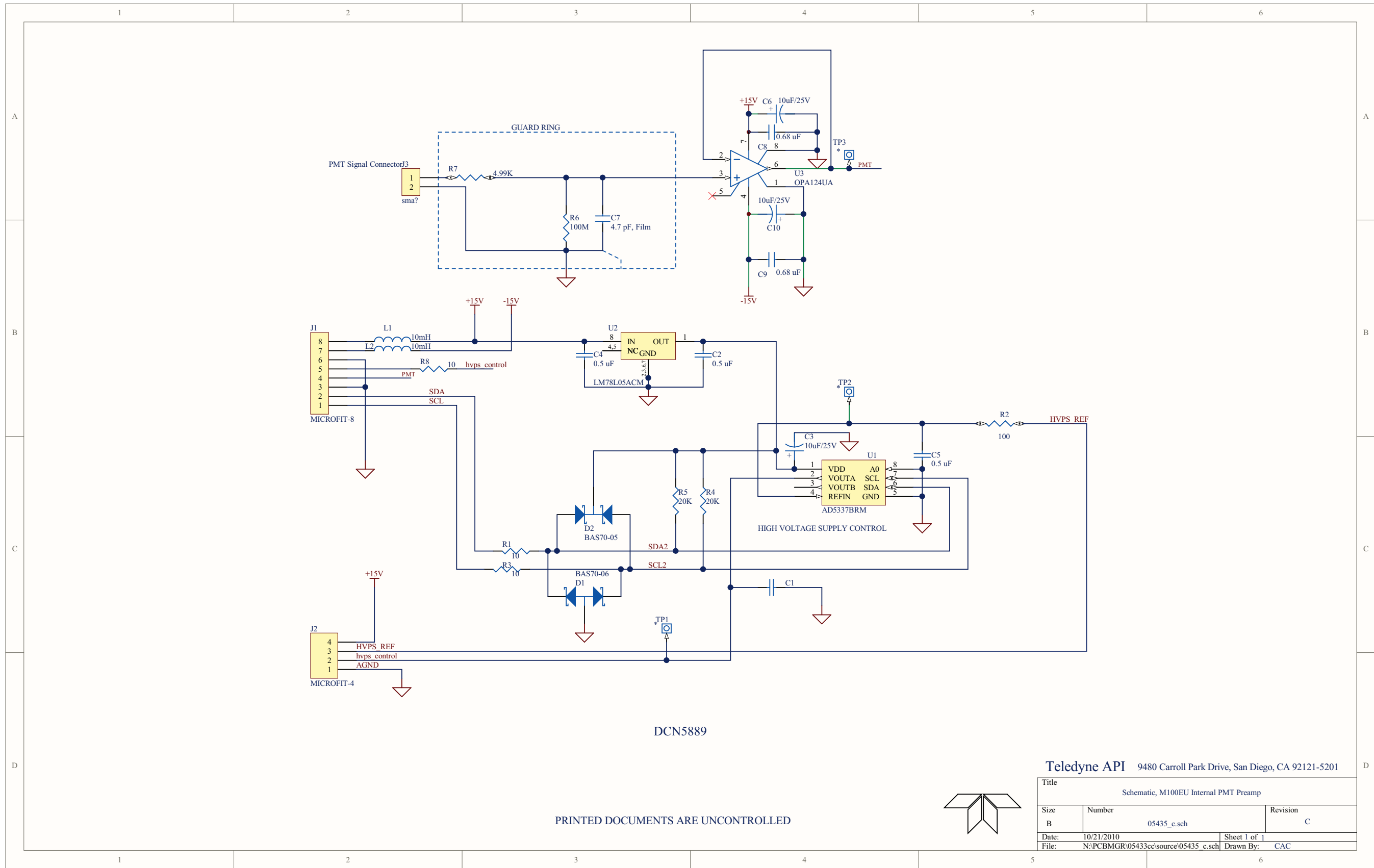

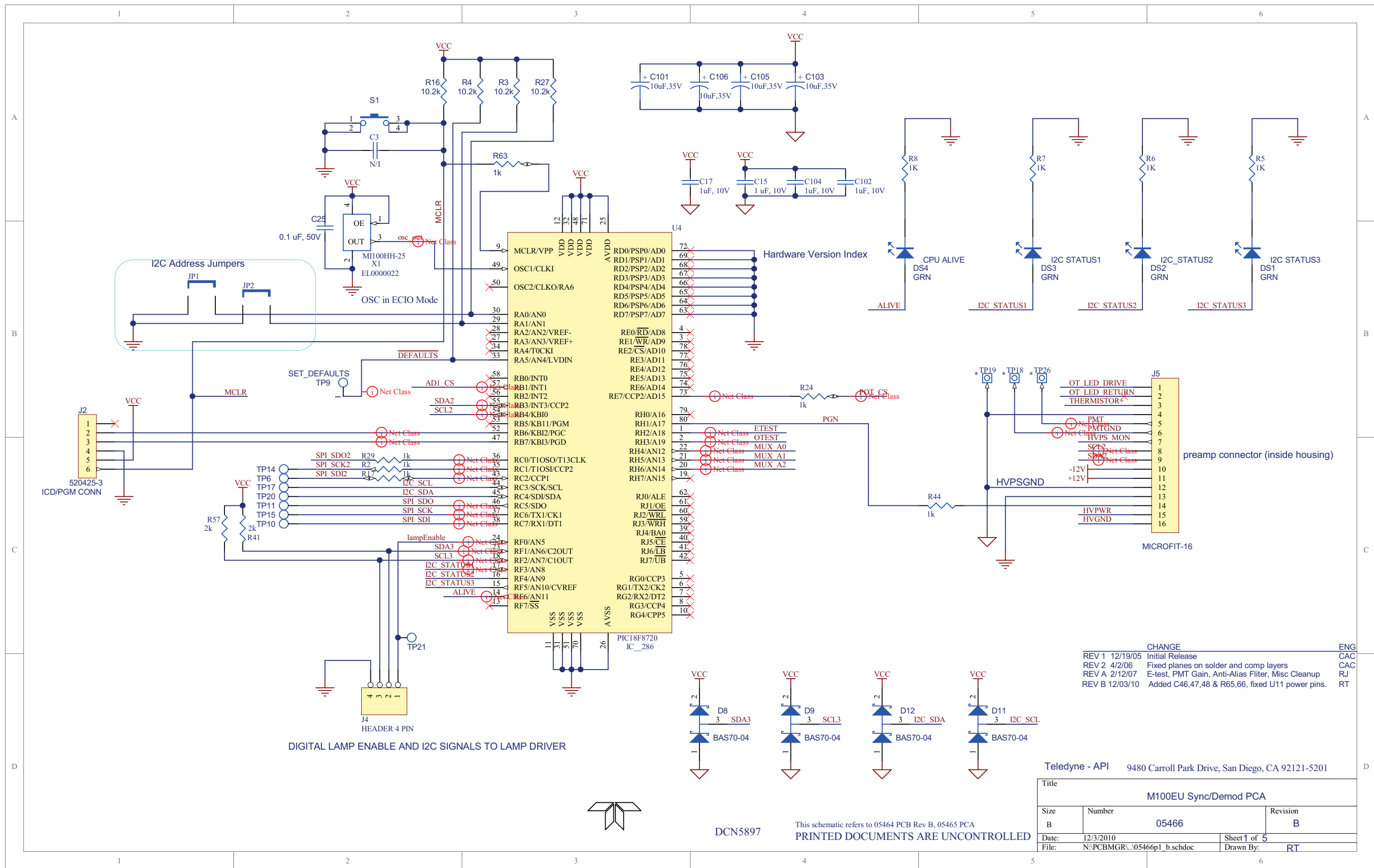

REV	DATE	DESCRIPTION	ENG
REV 1	12/19/05	Initial Release	CAC
REV 2	4/2/06	Fixed planes on solder and comp layers	CAC
REV A	2/12/07	E-test, PMT Gain, Anti-Alias Filter, Misc Cleanup	RJ
REV B	12/03/10	Added C46,47,48 & R65,66, fixed U11 power pins.	RT

Teledyne - API 9480 Carroll Park Drive, San Diego, CA 92121-5201

Title			M100EU Sync/Demod PCA		
Size	Number	Revision			
B	05466	B			
Date:	12/3/2010	Sheet 1 of 5			
File:	N:\PCBMGRU\05466p1_b.schdoc	Drawn By:	RT		

DCN5897 This schematic refers to 05464 PCB Rev B, 05465 PCA
PRINTED DOCUMENTS ARE UNCONTROLLED

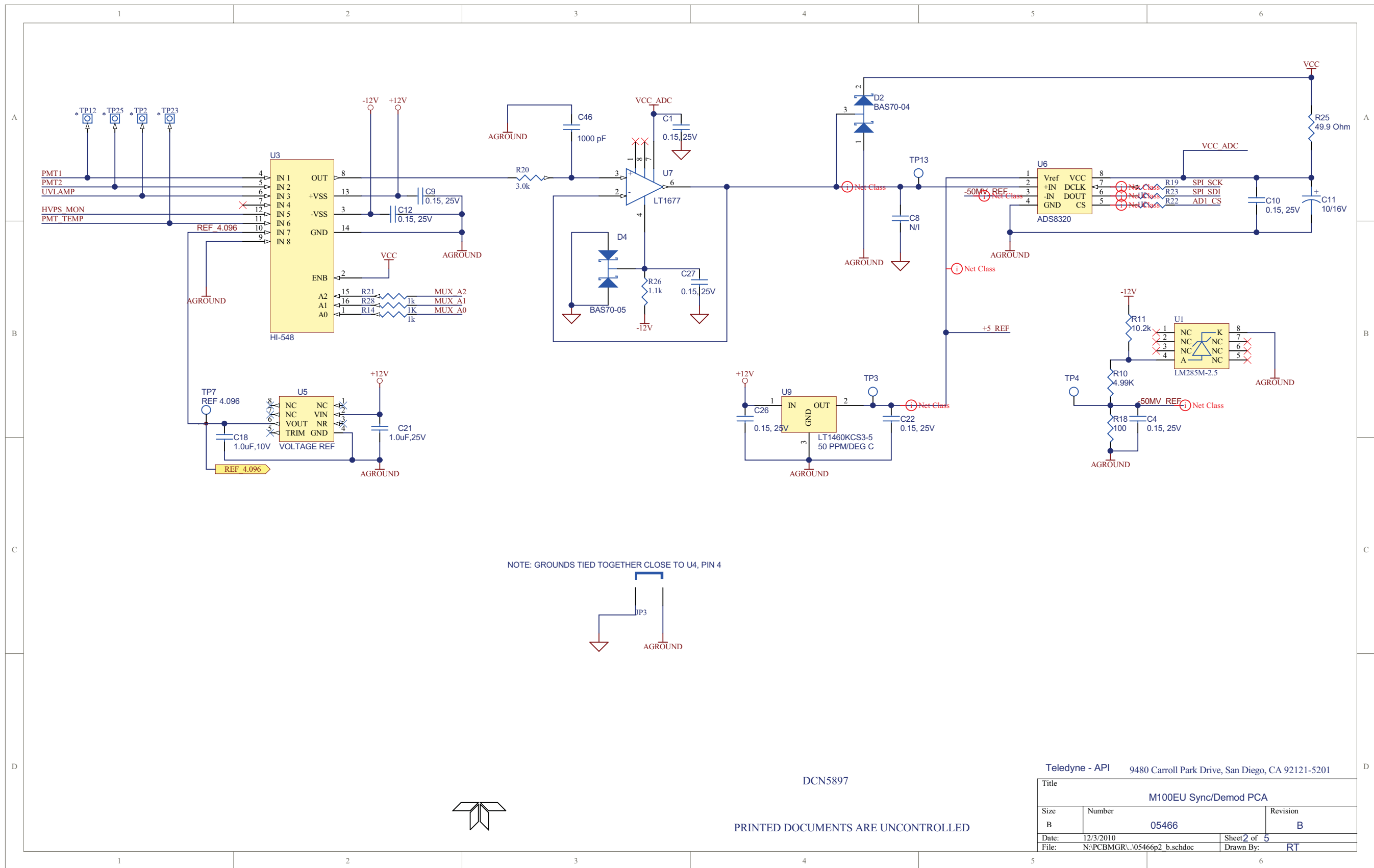

DCN5897

PRINTED DOCUMENTS ARE UNCONTROLLED

Teledyne - API 9480 Carroll Park Drive, San Diego, CA 92121-5201

Title		
M100EU Sync/Demod PCA		
Size	Number	Revision
B	05466	B
Date:	12/3/2010	Sheet 2 of 5
File:	N:\PCBMGR\05466p2_b.schdoc	Drawn By: RT

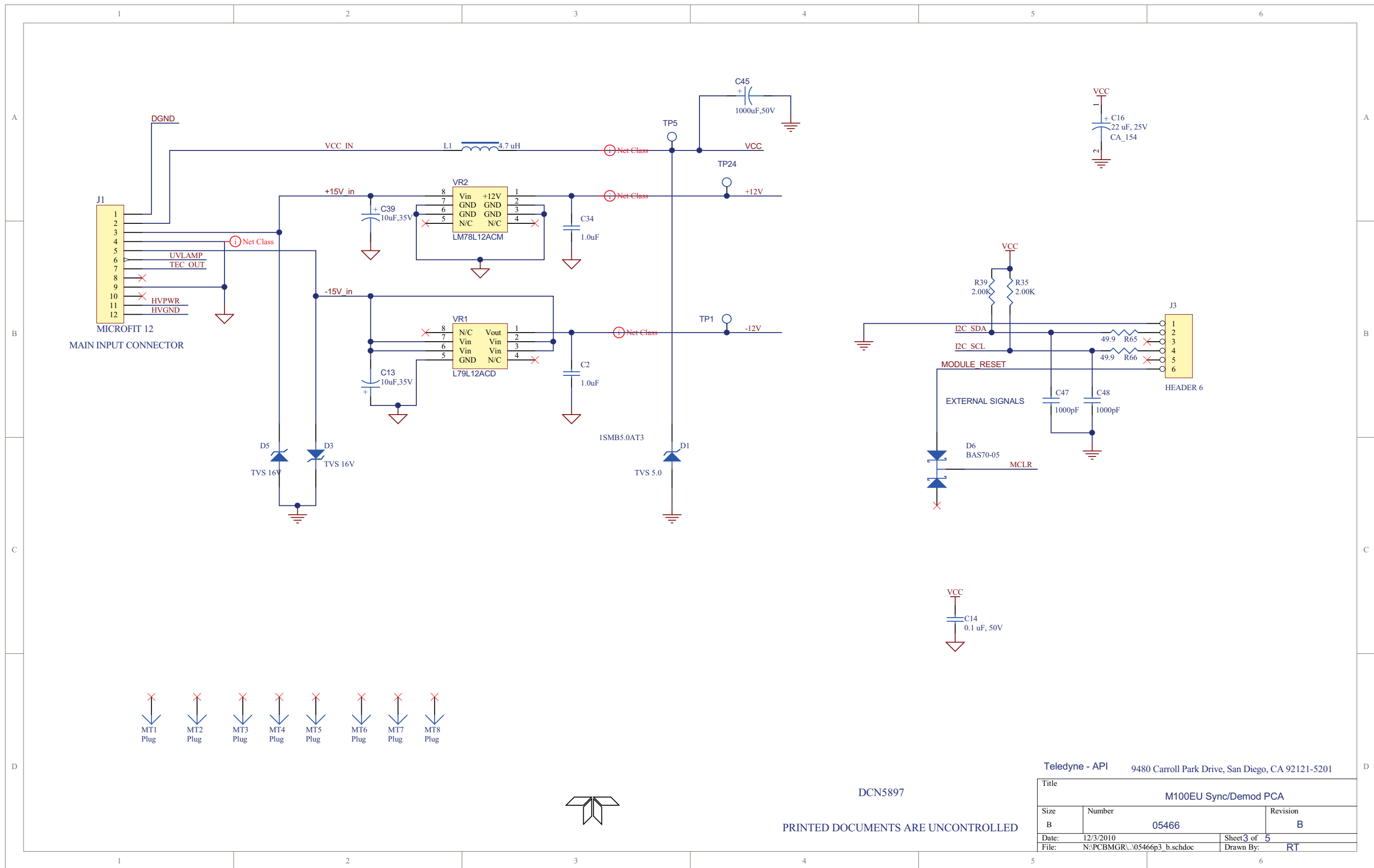

- MT1 Plug
- MT2 Plug
- MT3 Plug
- MT4 Plug
- MT5 Plug
- MT6 Plug
- MT7 Plug
- MT8 Plug

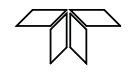

DCN5897

PRINTED DOCUMENTS ARE UNCONTROLLED

Teledyne - API 9480 Carroll Park Drive, San Diego, CA 92121-5201

Title			M100EU Sync/Demod PCA		
Size	Number	Revision			
B	05466	B			
Date:	12/3/2010	Sheet	3 of 5		
File:	N:\PCBMGRU\05466p3_b.schdoc	Drawn By:	RT		

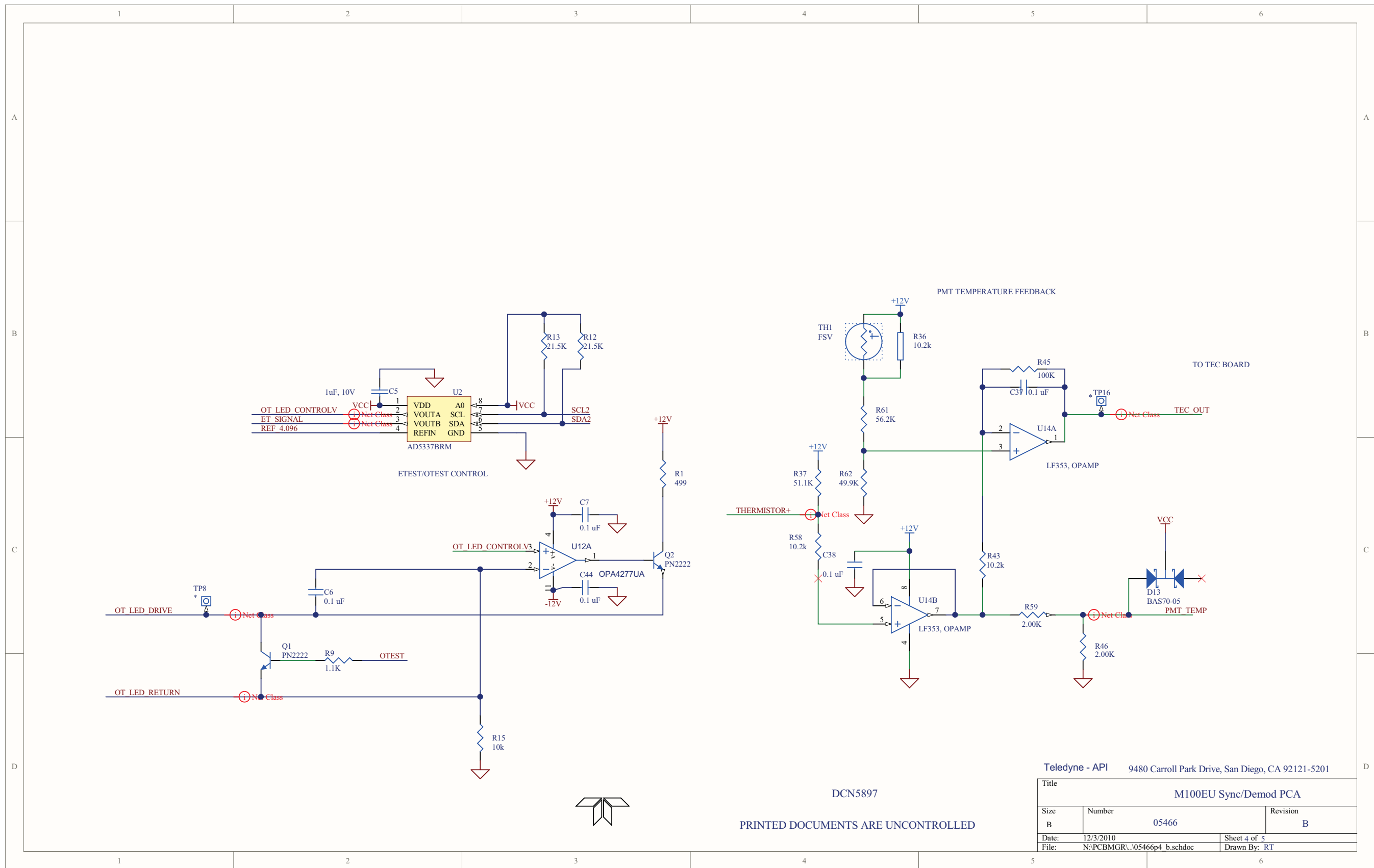

Teledyne - API 9480 Carroll Park Drive, San Diego, CA 92121-5201

Title			M100EU Sync/Demod PCA		
Size	Number	Revision			
B	05466	B			
Date:	12/3/2010	Sheet 4 of 5			
File:	N:\PCBMGRU\05466p4 b.schdoc	Drawn By: RT			

DCN5897
 PRINTED DOCUMENTS ARE UNCONTROLLED

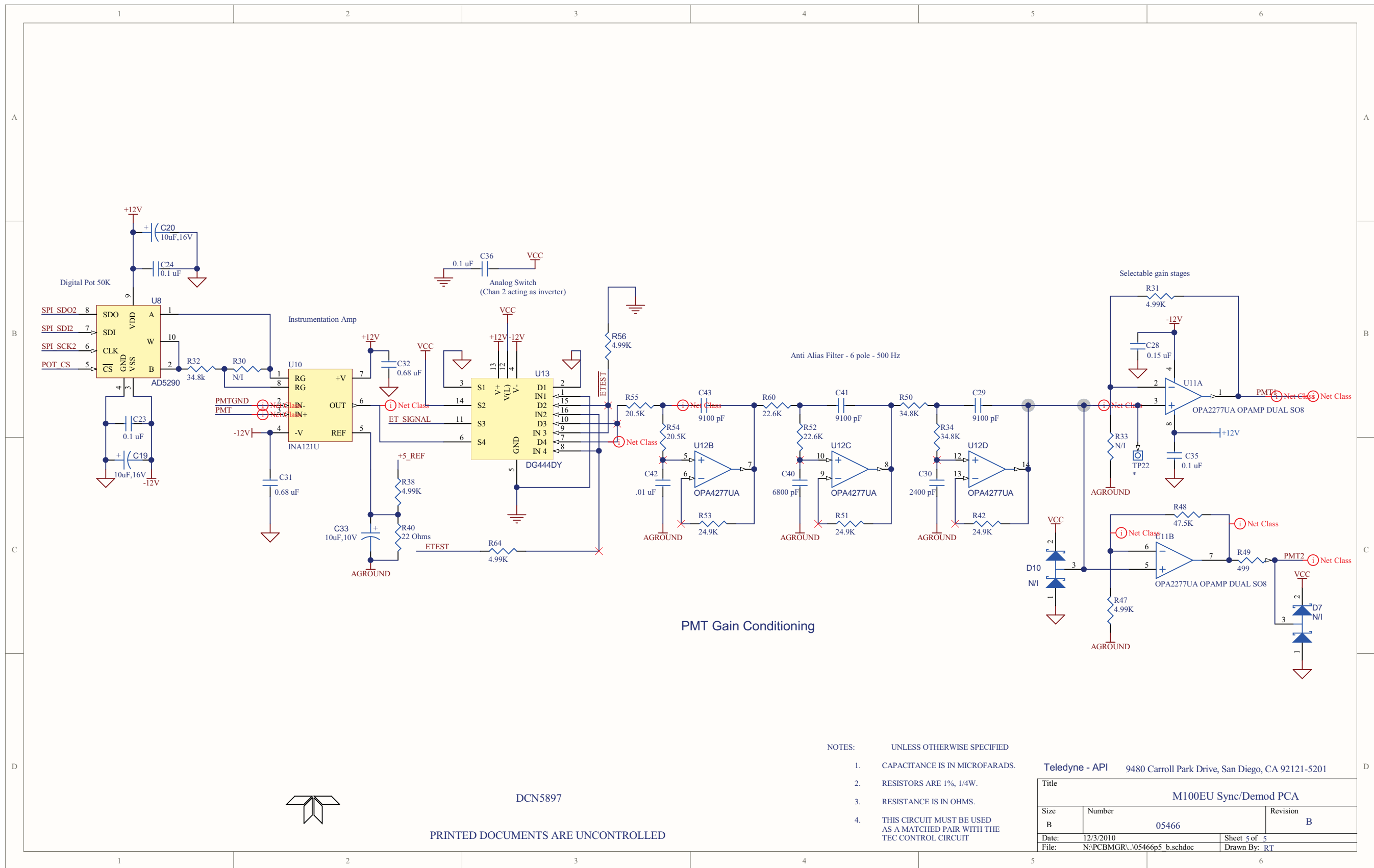

PMT Gain Conditioning

- NOTES: UNLESS OTHERWISE SPECIFIED
1. CAPACITANCE IS IN MICROFARADS.
 2. RESISTORS ARE 1%, 1/4W.
 3. RESISTANCE IS IN OHMS.
 4. THIS CIRCUIT MUST BE USED AS A MATCHED PAIR WITH THE TEC CONTROL CIRCUIT

Teledyne - API 9480 Carroll Park Drive, San Diego, CA 92121-5201

Title			M100EU Sync/Demod PCA		
Size	Number		Revision		
B	05466		B		
Date:	12/3/2010		Sheet	5 of 5	
File:	N:\PCBMGR\...05466p5_b.schdoc		Drawn By:	RT	

DCN5897

PRINTED DOCUMENTS ARE UNCONTROLLED

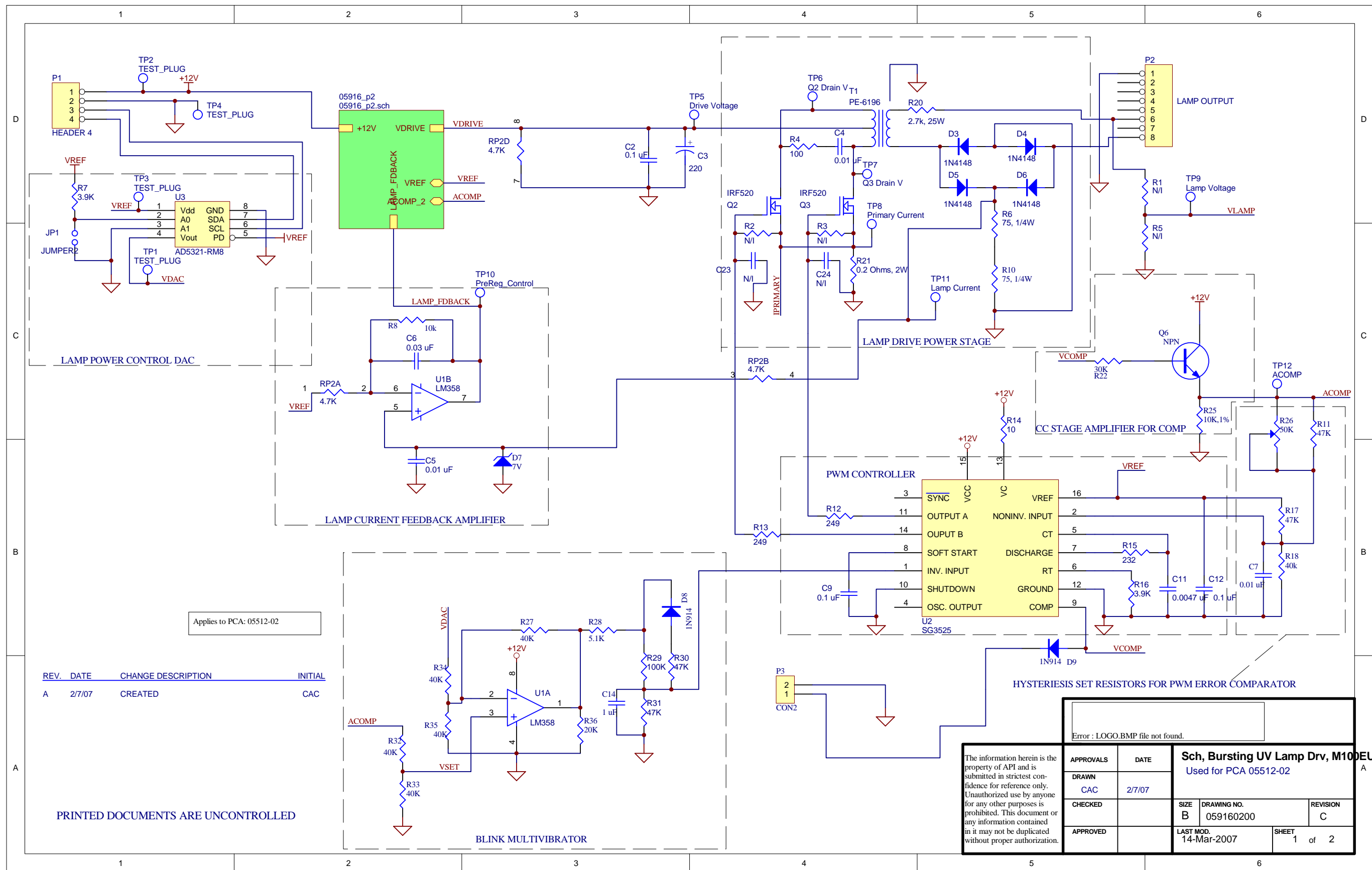

Applies to PCA: 05512-02

REV.	DATE	CHANGE DESCRIPTION	INITIAL
A	27/07	CREATED	CAC

PRINTED DOCUMENTS ARE UNCONTROLLED

The information herein is the property of API and is submitted in strictest confidence for reference only. Unauthorized use by anyone for any other purposes is prohibited. This document or any information contained in it may not be duplicated without proper authorization.

APPROVALS		DATE	Sch, Bursting UV Lamp Drv, M10DEU Used for PCA 05512-02	
DRAWN	CAC	2/7/07	SIZE	DRAWING NO.
CHECKED			B	059160200
APPROVED			REVISION	C
LAST MOD.			SHEET	
14-Mar-2007			1 of 2	

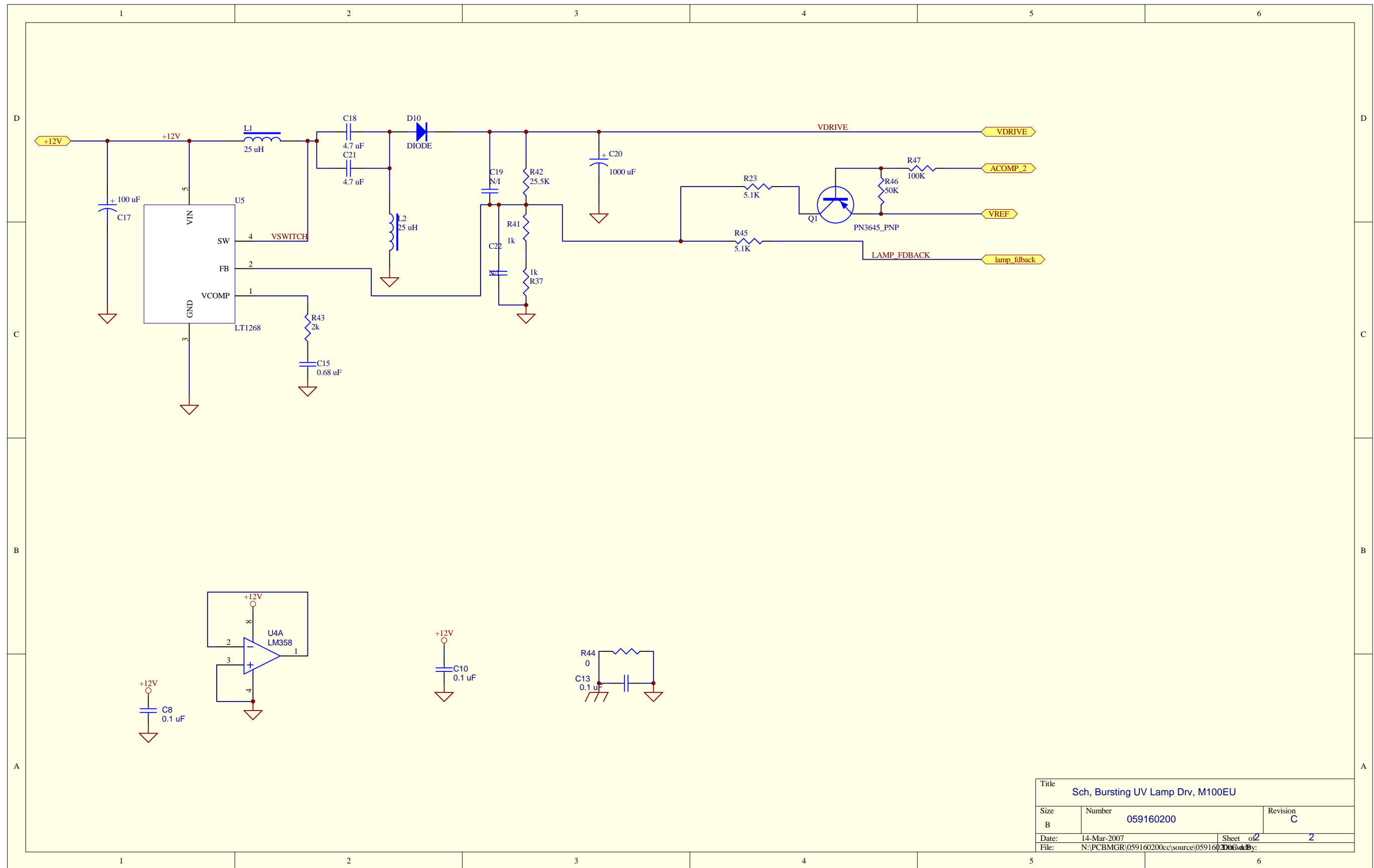

Title		
Sch, Bursting UV Lamp Drv, M100EU		
Size	Number	Revision
B	059160200	C
Date:	14-Mar-2007	Sheet of 2
File:	N:\PCBMGR\059160200\source\059160200.dwg	