

**09-003 Rev A**  
9 March, 2009

**M701 ADDING A SECONDARY (CO) SCRUBBER**

- I. PURPOSE:**  
To inform the customer on how to add a CO scrubber to a M701 that has an existing Hydrocarbon Scrubber.
- II. TOOLS:**  
Philips screwdriver
- III. PARTS:**  
KIT000288



The electronics used in T-API analyzers are sensitive to Electrostatic Discharge (ESD). When working on any T-API device, please ensure that you are properly grounded prior to handling or touching any electronic circuitry in the analyzers! For more information on how to protect sensitive components from ESD during handling, please contact T-API customer service and ask for the ESD Service note number 03-022A.

**IV. PROCEDURE:**

**CAUTION THE HC SCRUBBER IS HOT ENSURE PROPER COOL DOWN**

1. Turn off the M701, remove power cord & wait for the HC Scrubber to cool down.
2. Take the cover off of the M701.
3. Locate the Hydrocarbon Scrubber Assembly. The Hydrocarbon Scrubber is located behind the front panel on the left. See Figure 1.

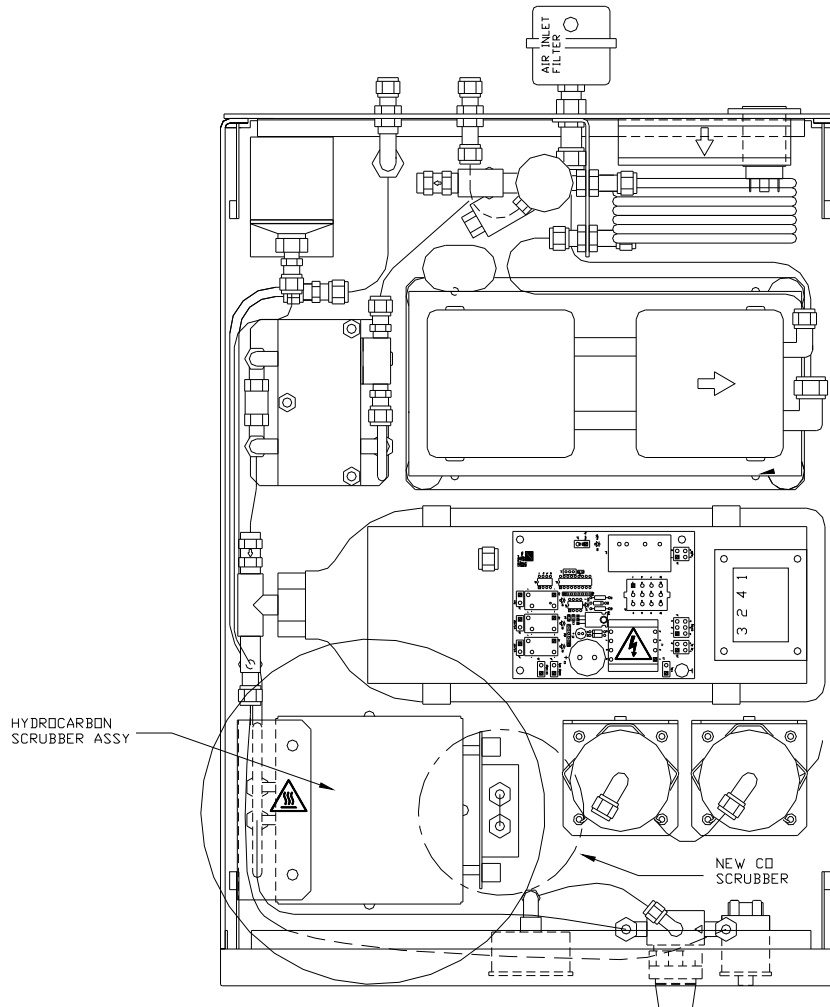

**FIGURE 1**

4. Locate the HC Scrubber temperature control board.
5. If the temperature control board already has the CO scrubber bracket on it skip to step 10. If not go to step 6.
6. Remove the CO scrubber bracket and standoffs from the KIT.
7. Remove the (4) four screws that hold the Temperature control board on to the HC scrubber and set aside.
8. Install the (4) four standoffs contained in the kit by screwing the male side of the standoffs into the same locations.
9. Next attach the CO bracket to the standoffs and screw in the (4) four screws removed in step 8.
10. Attach the CO scrubber as shown in Figure 2 with the (4) remaining screws contained in the kit.

## M701 ADDING A SECONDARY (CO) SCRUBBER

09-003 Rev A (DCN 5346) 03/12/09

Page 2 of 4

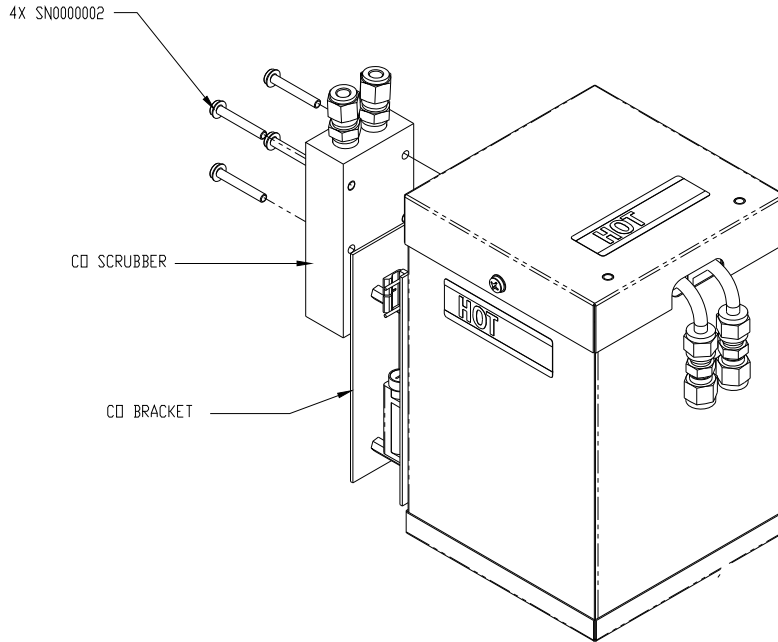

**FIGURE 2**

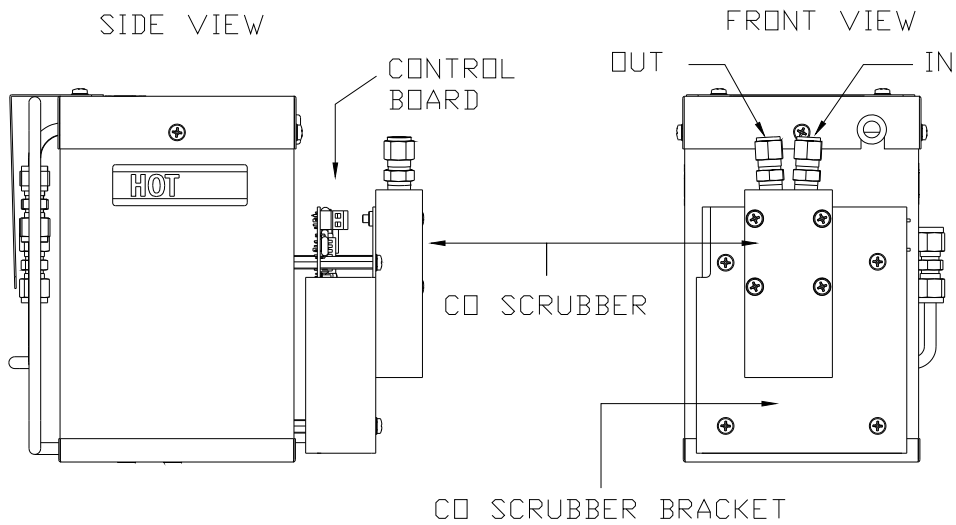

**FIGURE 3**

**M701 ADDING A SECONDARY (CO) SCRUBBER**

09-003 Rev A (DCN 5346) 03/12/09  
Page 3 of 4

## CONNECTING THE PNEUMATICS

1. Remove the pneumatic line that connects the rear panel filter to the charcoal scrubber.
2. Cut a piece of tubing long enough so that it reaches from the rear panel filter to the OUTLET port of new CO SCRUBBER.
3. Cut another piece of tubing long enough so that it reaches from the BOTTOM of the CHARCOAL SCRUBBER to the INLET of the CO SCRUBBER.
4. See FIGURE 4 for pneumatic connections.

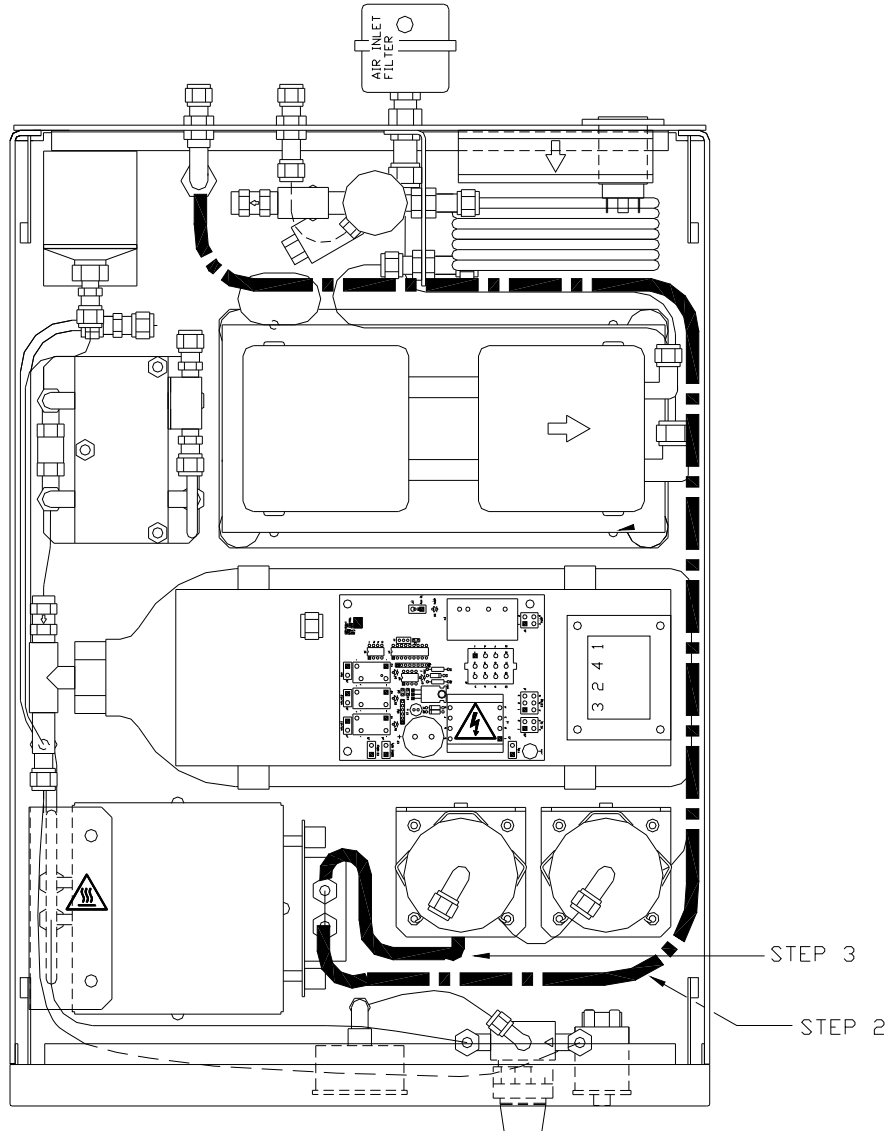

**FIGURE 4**

5. Perform a leak check on the M701.
6. The M701 is now ready for use.

If you have any questions regarding this service note please contact a Customer Service Representative at [api-customerservice@teledyne.com](mailto:api-customerservice@teledyne.com) or 858.657.9800.

### M701 ADDING A SECONDARY (CO) SCRUBBER

09-003 Rev A (DCN 5346) 03/12/09

Page 4 of 4