



**05-002A
7 October 2005**

RELAY BOARD RETROFIT (M200EX with MOLY CONVERTER)

I. PURPOSE:

To give instructions on How to install the relay board retrofit kit with MOLY converter in an M200E/EH/EM, 201E analyzer.

II. TOOLS:

Diagonal Cutters
Phillips head screwdriver

III. PARTS:

KIT000218



The electronics used in T-API analyzers are sensitive to Electrostatic Discharge (ESD). When working on any T-API device, please ensure that you are properly grounded prior to handling or touching any electronic circuitry in the analyzers! For more information on how to protect sensitive components from ESD during handling, please contact T-API customer service and ask for the ESD Service note number 03-022A.

IV. PROCEDURE:

1. Power down the instrument and remove the power plug from the instrument.
2. Remove the top cover from the instrument
3. Locate the relay board in Figure 1



FIGURE 1
M200E LAYOUT

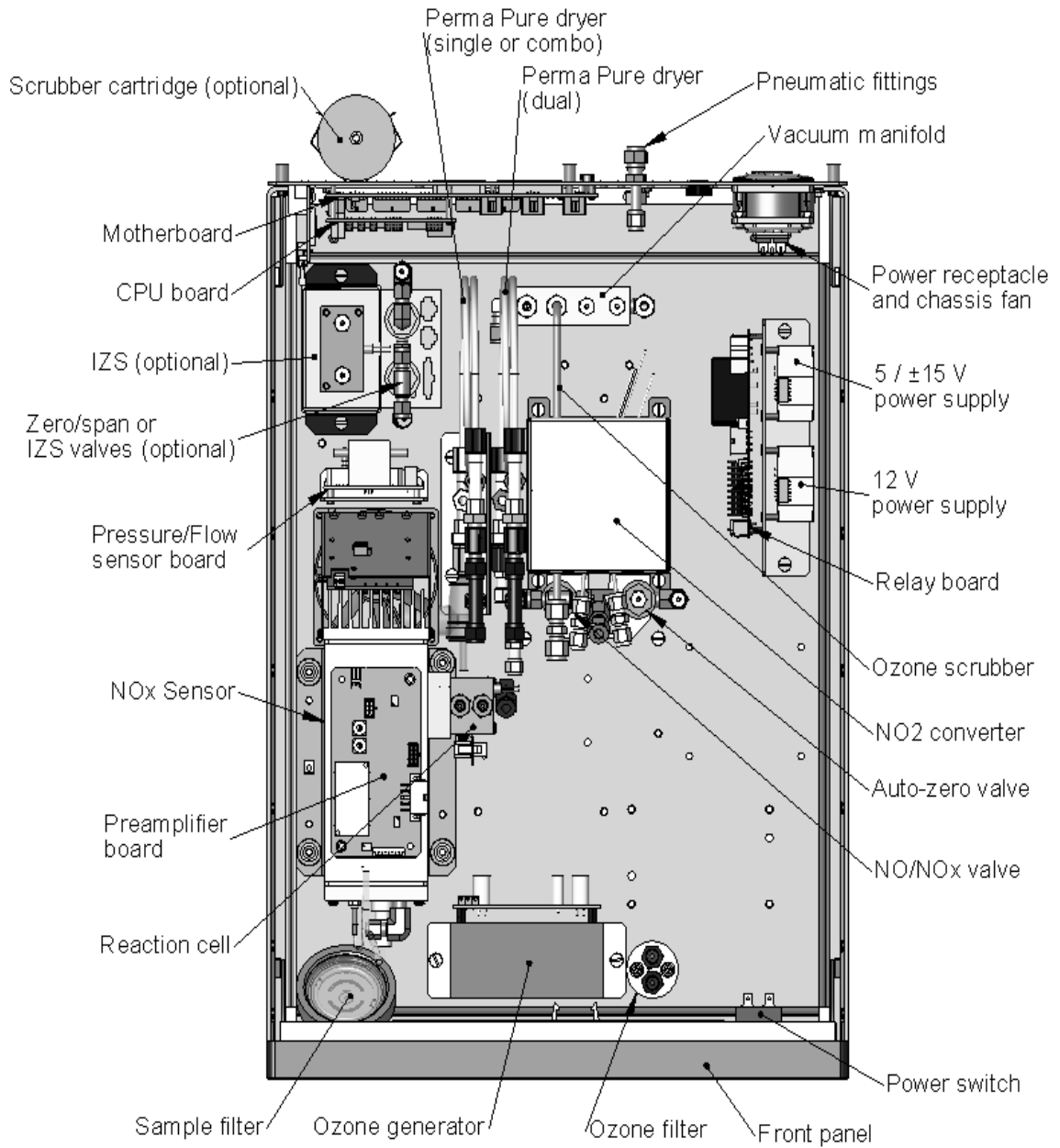



Removing the old Relay Board.

1. Remove each of the cables attached to the relay board.
2. Remove the (4) screws that hold the relay board to the mounting bracket.
3. Take the relay board and put it into an anti-static bag.

**FIGURE 2
OLD RELAY BOARD**

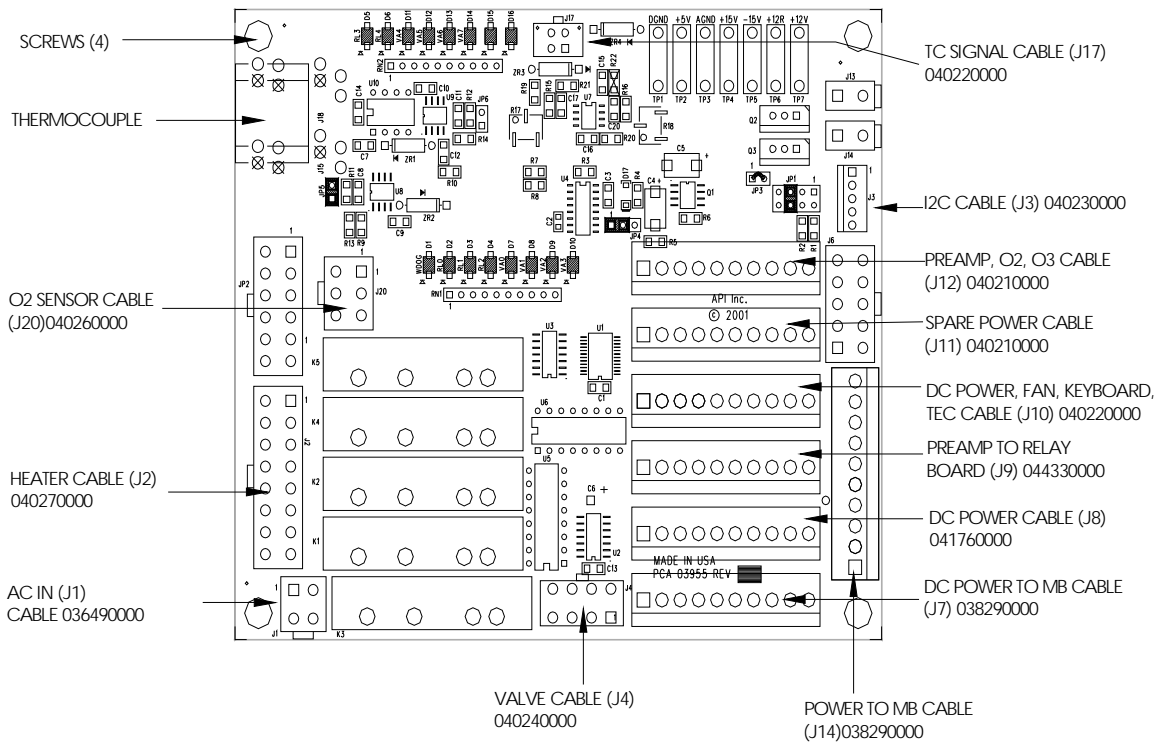



Installation of the new relay board.

1. Ensure that the 3 configuration plugs are installed, as shown in FIGURE 3 below.

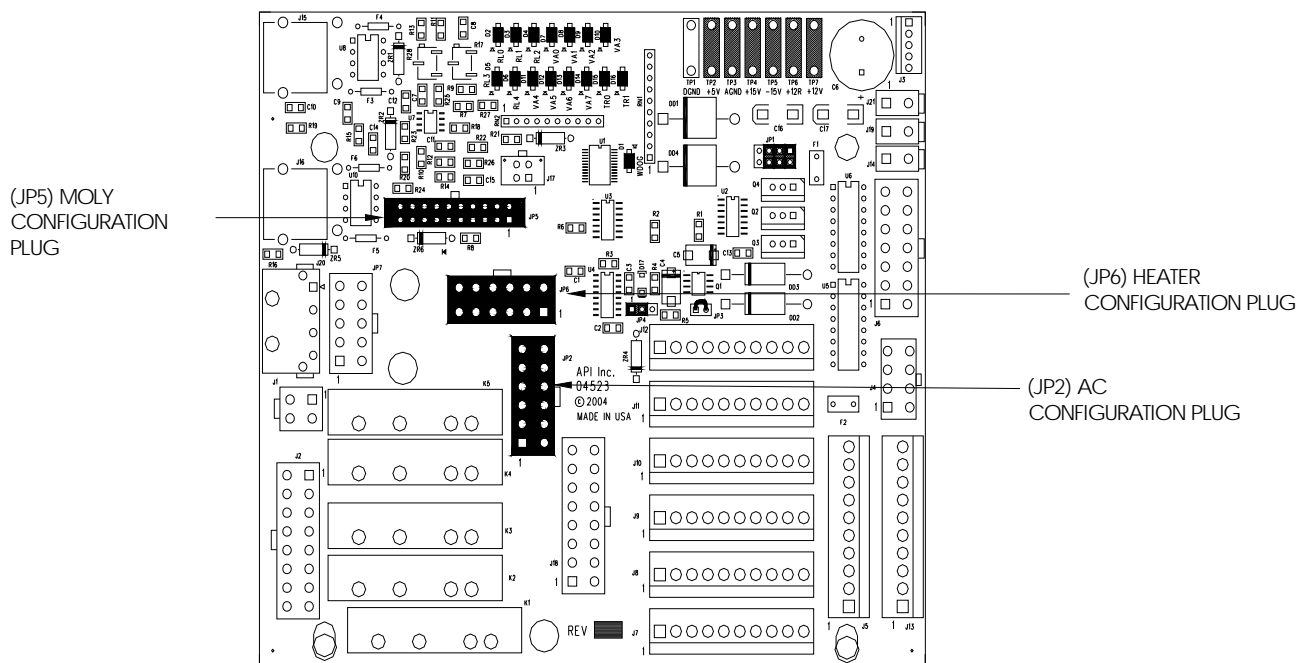

FIGURE 3

2. Position the new relay board as shown in Figure 3.
3. Tighten the 4 screws to fasten the relay board to the bracket.
4. Reconnect all of the cable assemblies except for the heater cable 040260000.
5. All of the connectors for each cable should be labeled (i.e. The cable with P5 on the connector connects to J5 on the relay board)
6. Take the 050570000 adapter cable from the KIT and connect the 6 pin connector to the 6 pin connector on the 040260000 cable.
7. Connect the 16pin connector on the 050570000 adapter cable to J18 on the relay board.
8. Turn on the instrument and give the instrument at least an hour for all of the temperatures to come up.



FIGURE 4
NEW RELAY BOARD 045230200

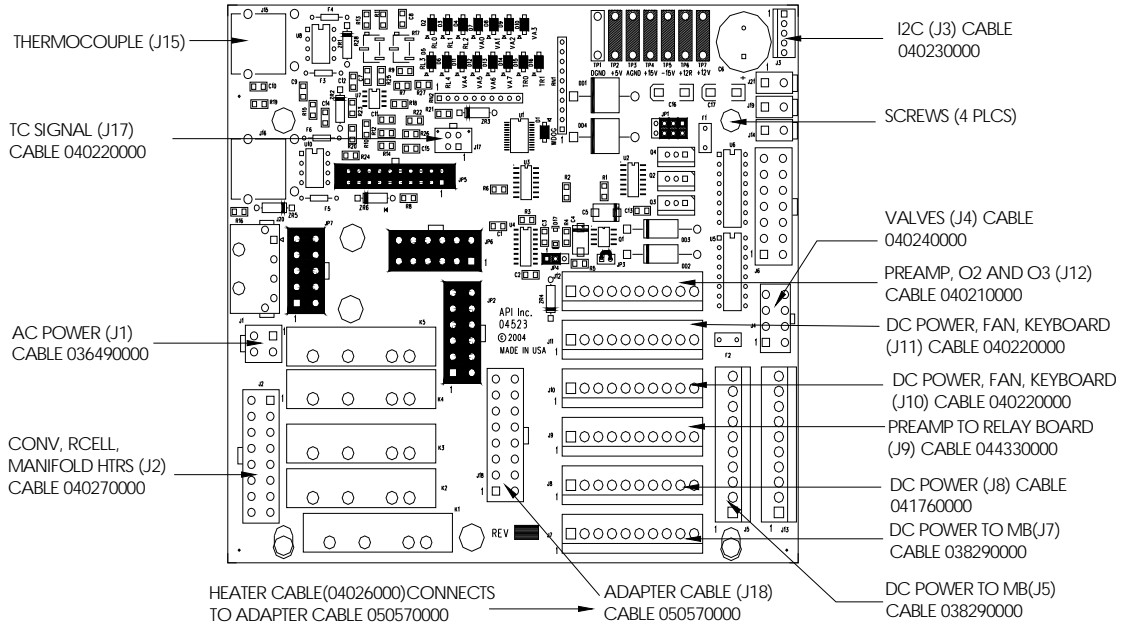
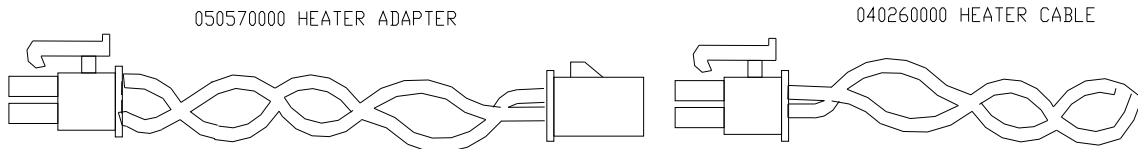

FIGURE 4
CONNECTING THE ADAPTER CABLE



9. Connect the adapter cable supplied in the KIT p/n 050570000 to the heater cable p/n 040260000. Attach the remaining connector to the relay board at J18.
10. Turn on the instrument and ensure that all the voltages are present on the relay board test points.
11. If the instrument has valves turn on each valve in the signal I/O and ensure that they are working.
12. Give the instrument at least an hour to warm up.
13. Verify that all temperatures are correct
14. The instrument is ready for normal operation.

If you experience problems with this retrofit or have any questions regarding this service note please contact API CUSTOMER SERVICE at api-customerservice@teledyne.com or call 800-324-5190.