



04-007C

1 October, 2008

ETHERNET RETROFIT KIT INSTALLATION PROCEDURE (NEW INSTRUMENTS)

I. PURPOSE:

How to install the Ethernet retrofit kit into an E-Series analyzer with the new version of rear panel. This kit is to be used with analyzers that have the Ethernet cut out on the rear panel. .

II. TOOLS:

Phillips screwdriver

9/16" wrench

5/8" wrench

Adjustable wrench

III. PARTS:

KIT000199 - ETHERNET RETROFIT KIT

IV. PROCEDURE:

1. Power down the instrument and remove the power cord.
2. Remove the instrument cover by removing the Phillips head screws on each side of the instrument.
3. Locate the rear panel of the instrument and lower it. This will give you easy access to the install the Ethernet board.
4. Remove the Ethernet card from the KIT and place it so that the connectors fit into the proper cut outs on the rear panel.
5. Fasten the Ethernet card using the two (2) screws provided in the KIT
6. Remove the cable provided in the kit.
7. Connect one end of the cable on the Ethernet board at PL101
8. Connect the other end of the ribbon cable to **CN4** on the CPU board.
9. You will need to find the power connector for the Ethernet board. It is located in the main wiring harness of the instrument.
10. The power connector is a red and black wire with a connector on it. The connector and wires should be tie wrapped into the instrument's main cable harness.

11. You may have to cut some tie wraps in order to free the connector from the harness. **BE SURE NOT TO CUT ANY WIRES, ONLY THE TIE WRAPS!**
12. Once the connector is free, plug it in to the mating connector at the top of the Ethernet board PL102. This is shown in Figure 1.
13. Figure 2 shows the complete installation of the boards to the rear panel.
14. Once the Ethernet option has been installed you must now enable the Ethernet interface and setup the configuration through the front panel of the instrument.

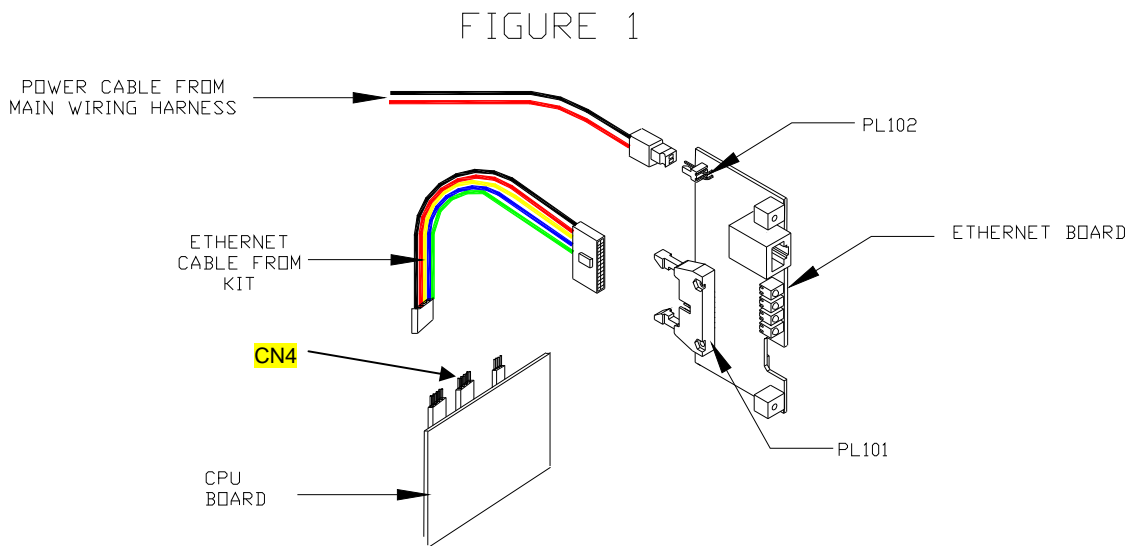

ETHERNET RETROFIT KIT INSTALLATION PROCEDURE (NEW INSTRUMENTS)

04-007 Rev C (DCN5141) 10/01/08

Page 2 of 7

FIGURE 2.
ETHERNET INSTALLATION

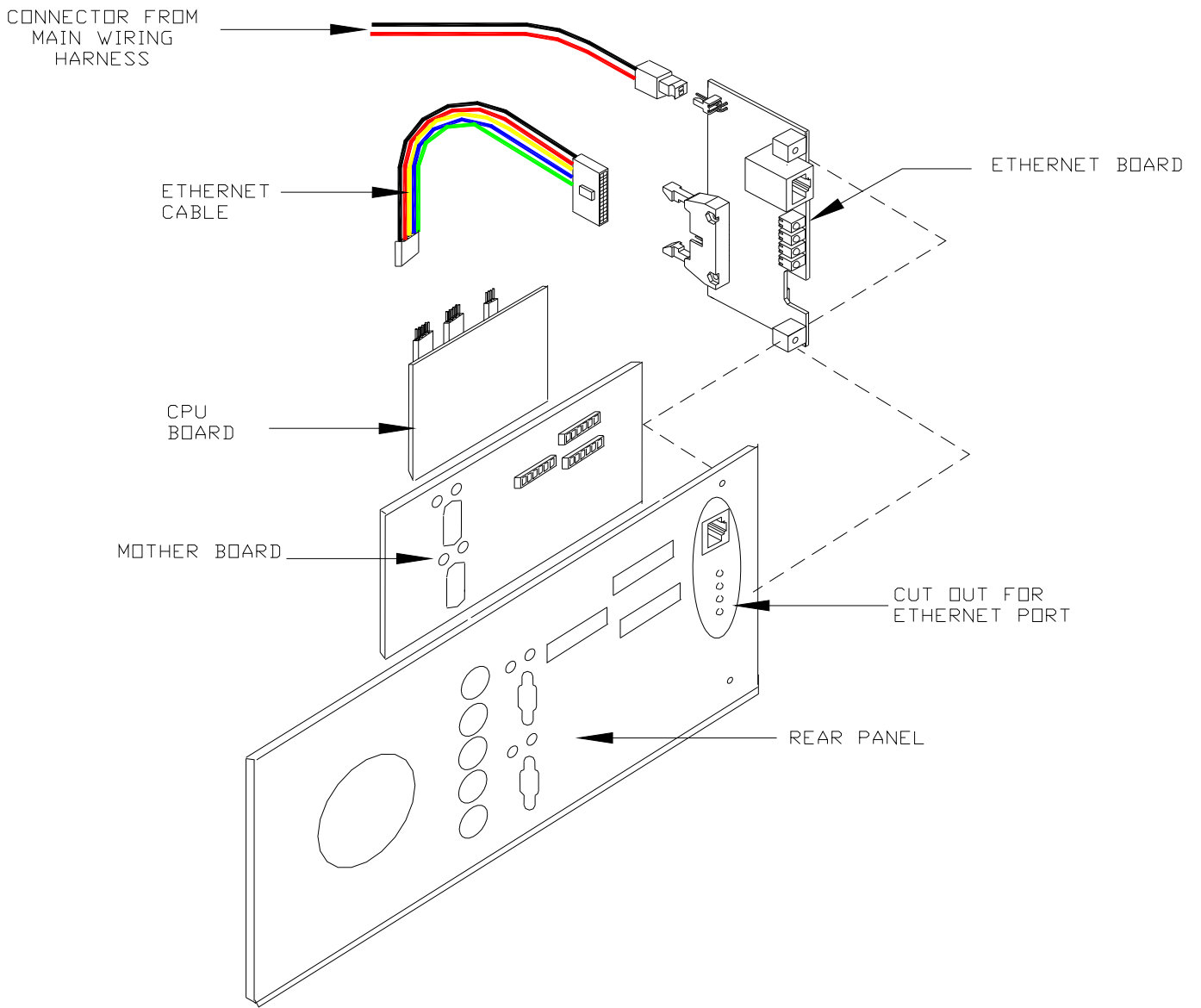

ETHERNET RETROFIT KIT INSTALLATION PROCEDURE (NEW INSTRUMENTS)

04-007 Rev C (DCN5141) 10/01/08

Page 3 of 7

ENABLING THE ETHERNET

1. From the main menu press SETUP-MORE-COM select COMB or COM2 depends on what version of software you have..
2. The baud rate for COMB/COM2 must be set to 115000 baud.
3. Each channel in COMB/COM2 must also be configured before proceeding.
4. Below is a table that explains each of the channels.

Mode	ID	Description
Quiet mode	1	Quiet mode suppresses any feedback from the analyzer (iDAS reports, and warning messages) to the remote device and is typically used when the port is communicating with a computer program such as APICOM. Such feedback is still available but a command must be issued to receive them.
Computer mode	2	Computer mode inhibits echoing of typed characters and is used when the port is communicating with a computer program, such as APICOM.
Security mode	4	When enabled, the serial port requires a password before it will respond. The only command that is active is the help screen (? CR).
Enable Internet	8	Enables the use and configuration of the Ethernet interface. When enabled, a new menu item INET will appear in the respective COM port menu.
Hessen protocol	16	The Hessen communications protocol is used in some European countries. T-API part number 02252 contains more information on this protocol.
Multidrop Protocol	32	Multidrop protocol allows a multi-instrument configuration on a single communications channel. Multidrop requires the use of instrument IDs.
Enable modem	64	Enables to send a modem initialization string at power-up. Asserts certain lines in the RS-232 port to enable the modem to communicate.
Ignore Errors	128	Fixes certain types of parity errors at certain Hessen protocol installations.
Disable XON/XOFF	256	Disables XON/XOFF data flow control.
	512	Unused
RS-485 mode	1024	Configures the COM2 Port for RS-485 communication. RS-485 mode has precedence over multidrop mode if both are enabled.
E, 7, 1	2048	This setting selects even parity, 7 data bits, and 1 stop bit for this com port; the default setting is always no parity, 8 data bits, and 1 stop bit. Used in conjunction with the Hessen protocol, hence, it is listed after ID 16
Command Prompt	4096	Enables a command prompt when in terminal mode.

5. Once you have set each channel to your specific needs you may proceed with the Ethernet card Configuration procedure.

Ethernet Card Configuration

The optional Ethernet card communicates with the analyzer through the COMB/COM2 serial port. The Ethernet card has two operational modes: Pass-through mode: This is the normal operation mode in which the card actively passes data between the RS-232 port and the RJ-45 connector on the analyzer's rear panel. This enables all remote commands to be passed to the analyzer.

ETHERNET RETROFIT KIT INSTALLATION PROCEDURE (NEW INSTRUMENTS)

04-007 Rev C (DCN5141) 10/01/08

Page 4 of 7

Configuration mode: The card stops passing data and is ready to accept and store configuration parameters and firmware upgrades. The use of a terminal window or separate configuration program is needed for these low-level configuration changes. The iChip configuration utility is available at <http://www.teledyne-api.com/software/> and provides a convenient, graphical user interface, which runs only on Microsoft Windows™ operating systems. All commands can also be issued via Terminal window using the AT+i protocol. Instructions for AT+i commands are also available at the website along with other pertinent information.

The Ethernet card has four LEDs that are visible on the rear panel of the analyzer, indicating its current operating status (Table 6-18).

Table 6-18: Ethernet Status Indicators

LED	Function
LNK (green)	ON when connection to the LAN is valid.
ACT (yellow)	Flickers on any activity on the LAN.
TxD (green)	Flickers when the RS-232 port is transmitting data.
RxD (yellow)	Flickers when the RS-232 port is receiving data.

As soon as the Ethernet option is enabled in the COMM menu, a new sub-menu **INET** will appear. This sub-menu is enabled by default when the analyzer was ordered with built-in Ethernet and is used to set configuration parameters that enable the Ethernet card to communicate with your local area network. To perform this configuration, you will need to get the following information from your network administrator:

- Gateway IP address, typically a string of numbers with four packets of 1 to 3 numbers each: nnn.nnn.nnn.nnn, for example: 192.168.76.1
- Instrument IP address, typically a string of numbers very similar to the Gateway IP address, for example: 192.168.76.55. Note that this instrument IP address must be a static address and cannot be a dynamic IP address. DHCP and analyzer host names are not supported at this time.
- Subnet Mask, typically a string of numbers such as 255.255.252.0
- The communications port number is set to 3000 by default and should not be changed.

The following procedures assume that the Ethernet card is already installed in your analyzer. If you are retro-fitting the analyzer with an Ethernet Option 63, please make sure to enable the internet option as described in the Enabling the

Ethernet procedure on the previous page. Ensure that the baud rate is set to 115000.

Once Ethernet is enabled for the COM2 port, the first step in configuring the Ethernet option is to set the card from pass-through mode to configuration mode, so that TCP/IP parameters can be edited.

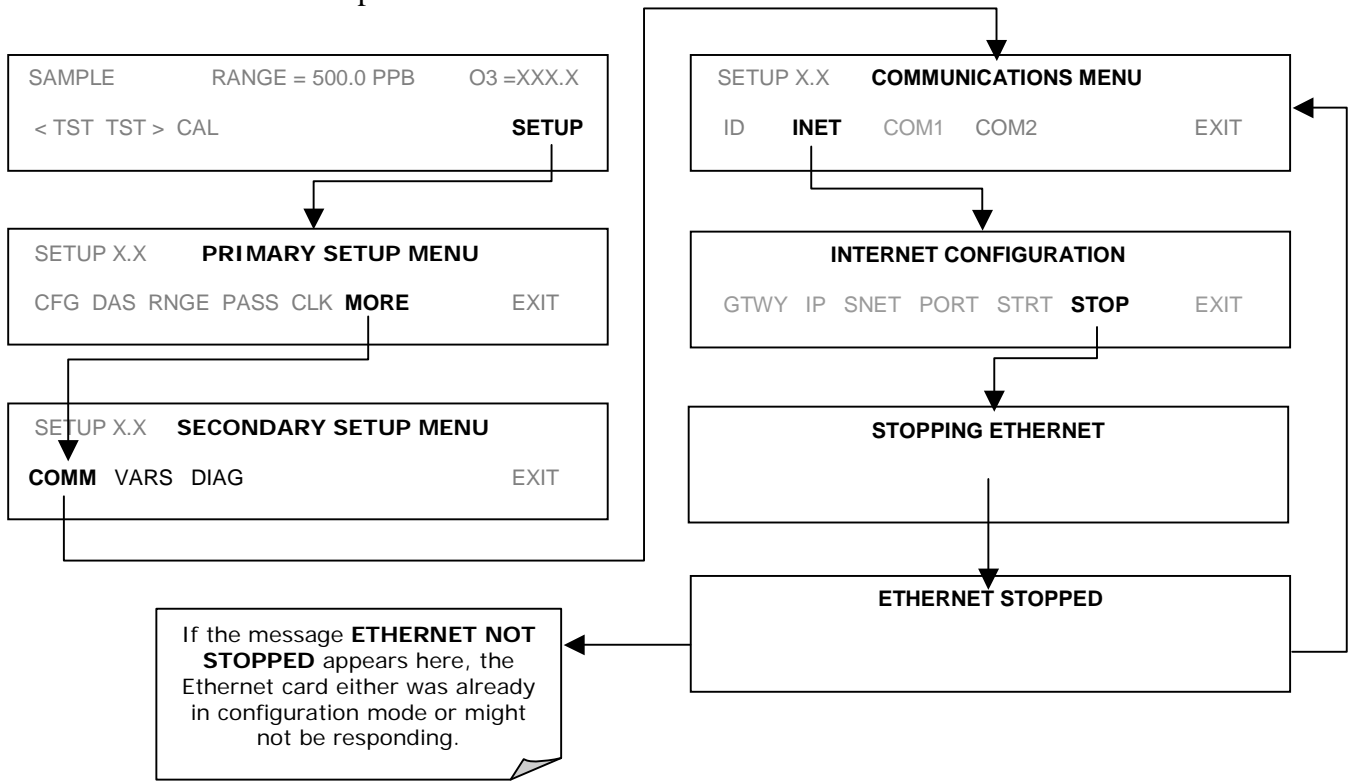

Step two in the configuration process is to edit the TCP/IP parameters.

Step three in the configuration process is to restart the pass-through mode for normal operation.

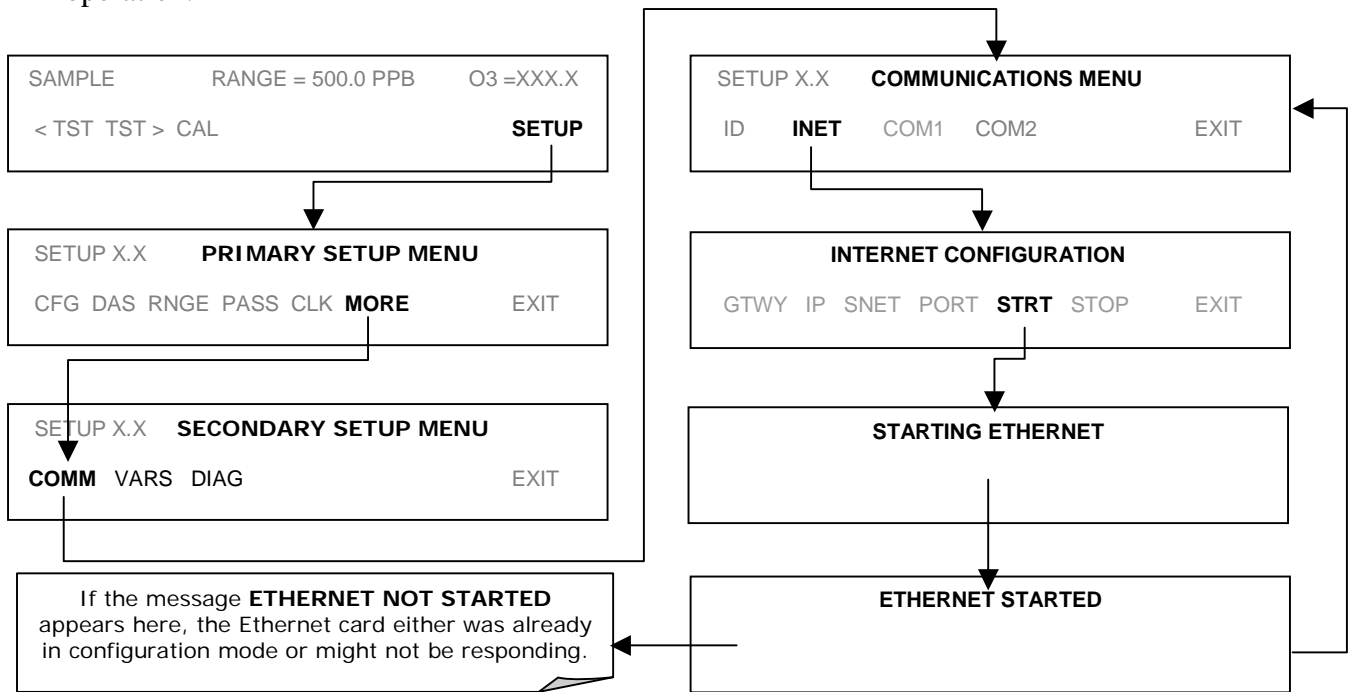

ETHERNET RETROFIT KIT INSTALLATION PROCEDURE (NEW INSTRUMENTS)

04-007 Rev C (DCN5141) 10/01/08