



**TELEDYNE**  
ADVANCED POLLUTION INSTRUMENTATION  
A Teledyne Technologies Company

# T200U-NO<sub>y</sub> ANALYZER

## ADDENDUM

(for use with T200 Operators Manual, PN 06858  
and with the T200U Addendum, PN 06861)

© TELEDYNE ADVANCED POLLUTION INSTRUMENTATION  
9480 CARROLL PARK DRIVE  
SAN DIEGO, CA 92121-5201  
USA

Toll-free Phone: 800-324-5190  
Phone: 858-657-9800  
Fax: 858-657-9816  
Email: [api-sales@teledyne.com](mailto:api-sales@teledyne.com)  
Website: <http://www.teledyne-api.com/>

Copyright 2011  
Teledyne Advanced Pollution Instrumentation

Part Number 07303A  
(DCN5948)  
03 January 2011







## Safety Messages

Important safety messages are provided throughout this manual for the purpose of avoiding personal injury or instrument damage. Please read these messages carefully. Each safety message is associated with a safety alert symbol, and are placed throughout this manual and inside the instrument. The symbols with messages are defined as follows:



**WARNING:** Electrical Shock Hazard



**HAZARD:** Strong oxidizer



**GENERAL WARNING/CAUTION:** Read the accompanying message for specific information.



**CAUTION:** Hot Surface Warning



**Do Not Touch:** Touching some parts of the instrument without protection or proper tools could result in damage to the part(s) and/or the instrument.



**Technician Symbol:** All operations marked with this symbol are to be performed by qualified maintenance personnel only.



**Electrical Ground:** This symbol inside the instrument marks the central safety grounding point for the instrument.

### CAUTION



This instrument should only be used for the purpose and in the manner described in this manual. If you use this instrument in a manner other than that for which it was intended, unpredictable behavior could ensue with possible hazardous consequences.

**NEVER** use any gas analyzer to sample combustible gas(es)!

### Note

For Technical Assistance regarding the use and maintenance of this instrument or any other Teledyne API product, contact Teledyne API's Customer Service Department:

Telephone: 800-324-5190

Email: [api-customerservice@teledyne.com](mailto:api-customerservice@teledyne.com)

or access any of the service options on our website at <http://www.teledyne-api.com/>

# CONSIGNES DE SÉCURITÉ

Des consignes de sécurité importantes sont fournies tout au long du présent manuel dans le but d'éviter des blessures corporelles ou d'endommager les instruments. Veuillez lire attentivement ces consignes. Chaque consigne de sécurité est représentée par un pictogramme d'alerte de sécurité; ces pictogrammes se retrouvent dans ce manuel et à l'intérieur des instruments. Les symboles correspondent aux consignes suivantes :



**AVERTISSEMENT** : Risque de choc électrique



**DANGER** : Oxydant puissant



**AVERTISSEMENT GÉNÉRAL / MISE EN GARDE** : Lire la consigne complémentaire pour des renseignements spécifiques



**MISE EN GARDE** : Surface chaude



**Ne pas toucher** : Toucher à certaines parties de l'instrument sans protection ou sans les outils appropriés pourrait entraîner des dommages aux pièces ou à l'instrument.



**Pictogramme « technicien »** : Toutes les opérations portant ce symbole doivent être effectuées uniquement par du personnel de maintenance qualifié.



**Mise à la terre** : Ce symbole à l'intérieur de l'instrument détermine le point central de la mise à la terre sécuritaire de l'instrument.

## MISE EN GARDE



Cet instrument doit être utilisé aux fins décrites et de la manière décrite dans ce manuel. Si vous utilisez cet instrument d'une autre manière que celle pour laquelle il a été prévu, l'instrument pourrait se comporter de façon imprévisible et entraîner des conséquences dangereuses.

**NE JAMAIS** utiliser un analyseur de gaz pour échantillonner des gaz combustibles!

# Table of Contents

Safety Messages .....	i
<b>CONSIGNES DE SÉCURITÉ .....</b>	<b>II</b>
Table of Contents.....	iii
List of Figures .....	iv
List of Tables.....	iv
<b>1.0 INTRODUCTION .....</b>	<b>5</b>
<b>2.0 GETTING STARTED .....</b>	<b>7</b>
2.1 Unpacking and Inspection .....	7
2.2 Electrical and Pneumatic Connections .....	7
2.3 Initial Operation.....	11
<b>3.0 SPECIFICATIONS, WARRANTY .....</b>	<b>13</b>
3.1 Specifications.....	13
3.2 Warranty.....	14
<b>4.0 THE T200U-NOY EXTERNAL CONVERTER.....</b>	<b>15</b>
4.1 Principle of Operation .....	15
<b>5.0 CALIBRATION AND ZERO/SPAN (OPTION) CHECKS .....</b>	<b>17</b>
5.1 Calibration or Cal Check Procedure .....	18
<b>6.0 MAINTENANCE .....</b>	<b>21</b>
6.1 Maintenance Schedule .....	21
6.2 Replacing the Sample Particulate Filters .....	22
6.3 Checking Analyzer Flow Rate .....	24
6.4 Replacing the Converter .....	24
6.5 Inspecting Pneumatic Lines .....	26
6.6 Checking for Leaks.....	28
<b>7.0 TROUBLESHOOTING, ADJUSTMENTS.....</b>	<b>31</b>
7.1 Operation Verification – Diagnostic Techniques .....	31
7.1.1 Pneumatic System.....	31
7.1.2 Leak Check.....	33
7.1.3 501Y Bypass Pump Diagnostic Procedures .....	33
7.1.4 Electrical Fault Isolation.....	33

---

<b>7.2 Setting the Converter Temperature .....</b>	<b>33</b>
7.2.1 Temperature Controller Setup .....	34
<b>8.0 T200U-NOY SPARE PARTS LIST .....</b>	<b>37</b>

## ***List of Figures***

<b>FIGURE 1. REAR PANELS: T200U NOY (TOP) AND 501Y (CENTER); CONVERTER (BOTTOM).....</b>	<b>9</b>
<b>FIGURE 2. REAR PANEL PNEUMATIC CONNECTIONS .....</b>	<b>10</b>
<b>FIGURE 3 REPLACING THE PARTICULATE FILTER .....</b>	<b>23</b>
<b>FIGURE 4 NOY CONVERTER GUTS ASSEMBLY LOCATION.....</b>	<b>25</b>
<b>FIGURE 5. PNEUMATICS DIAGRAM .....</b>	<b>27</b>
<b>FIGURE 6 LOCATION OF O<sub>3</sub> GENERATOR AIR INLET .....</b>	<b>28</b>
<b>FIGURE 7 PNEUMATIC DIAGRAM.....</b>	<b>32</b>
<b>FIGURE 8 ELECTRICAL DIAGRAM.....</b>	<b>36</b>

## ***List of Tables***

<b>TABLE 1 FINAL TEST AND CALIBRATION VALUES .....</b>	<b>11</b>
<b>TABLE 2 SPECIFICATIONS FOR THE EXTERNAL CONVERTER AND THE BYPASS PUMP .....</b>	<b>13</b>
<b>TABLE 3 MANUAL ZERO CALIBRATION PROCEDURE - ZERO GAS THROUGH SAMPLE PORT .....</b>	<b>18</b>
<b>TABLE 4 ENTER EXPECTED SPAN GAS CONCENTRATIONS PROCEDURE FOR NO &amp; NOY .....</b>	<b>19</b>
<b>TABLE 5 SPAN CALIBRATION PROCEDURE .....</b>	<b>19</b>
<b>TABLE 6 PREVENTATIVE MAINTENANCE CALENDAR.....</b>	<b>21</b>
<b>TABLE 7 TEMPERATURE CONTROLLER PROGRAMMING GUIDE.....</b>	<b>34</b>



## **1.0 INTRODUCTION**

The T200U-NO<sub>y</sub> analyzer consists of an external Converter designed to support a NO<sub>x</sub> analyzer by converting multiple, unstable compounds grouped under the name **NO<sub>y</sub>**. The converter is mounted externally at the sample inlet to minimize flow time between sample in and converter, thereby optimizing measurement accuracy.

This manual addendum is to be used in conjunction with two additional documents with operation instructions:

- T200 operation manual (part number 06858)
- T200U addendum (part number 06861).

It is recommended that you read/familiarize yourself with all sets of instructions in order to use the analyzer and converter correctly.

This page intentionally left blank.

## 2.0 GETTING STARTED

The NOy converter has been designed to operate with the T200U low level NOx analyzer, with some additional modification. The combination is referred to as the T200U-NOy analyzer.

### 2.1 Unpacking and Inspection



#### CAUTION!

Avoid personal injury: use two persons each to lift and carry the analyzer and the Model 501 Pump Pack chassis.

The T200U- NOy comes in three boxes:

- The analyzer with AC power cord
  - 501Y Bypass Pump Chassis (typically referred to as “501Y herein) with AC power cord
  - External Converter housed in a stainless steel shelter, and an umbilical cable assembly (herein referred to as “Converter” or “external Converter”)
  - External Pump (herein referred to as “external Pump” not to be confused with the 501Y Bypass Pump)
1. Verify that there is no apparent shipping damage. If damage has occurred please advise shipper first, then TAPI. (Keep original container and packaging for shipper’s inspection).
  2. Before operating the analyzer, remove the shipping screws as shown in the T200 Manual.
  3. Please check the voltage and frequency label on the rear panel of the instrument for compatibility with the local power before connecting the instruments to a power source.

### 2.2 Electrical and Pneumatic Connections

#### NOTE

To maintain compliance with EMC standards, it is required that the cable length (at the rear of the analyzer) be no greater than 3 meters for all I/O connections, which include Analog In, Analog Out, Status Out, Control In, Ethernet/LAN, USB, RS-232, and RS-485.

1. Mount the Converter (**Figure 1**, bottom) on a suitable mast.
2. Route the umbilical cable assembly into the shelter of the Converter.
3. Locate the analyzer and 501Y Bypass Pump Chassis in close proximity, preferably mounting one over the other in a 19” rack.
4. Connect the T200U-NOy analyzer rear panel electrical connectors per the T200 operation manual.
5. Connect the pneumatic cable fittings from the analyzer rear panel (**Figure 1**, top) to the 501Y rear panel (**Figure 1**, center) and from the 501Y rear panel to the Converter (**Figure 1**, bottom).

Refer to **Figure 2** for an illustration of the connections; refer to the tags on each tube to

match up the correct tube with the appropriate rear panel fitting. Please note that the dashed lines in **Figure 2** show optional Zero/Span Valve configuration connections.

6. Also connect the EXHAUST port of the analyzer rear panel to the external Pump.
7. Connect the 7-pin power and signal cable from the external Converter's umbilical cable assembly to the CONVERTER POWER connector on the rear of the 501Y.
8. Connect the analyzer and 501Y AC power cords from their AC power receptacles to the correct line voltage (refer to power specs on the respective rear panel label).

### **WARNING!**



- Lethal voltages are present inside the chassis.
- Do not operate with cover off during normal operation
- Before operation, check for correct input voltage and frequency.
- Do not operate without proper chassis grounding
- Do not defeat the ground wire on power plug
- Turn off power before disconnecting electrical subassemblies

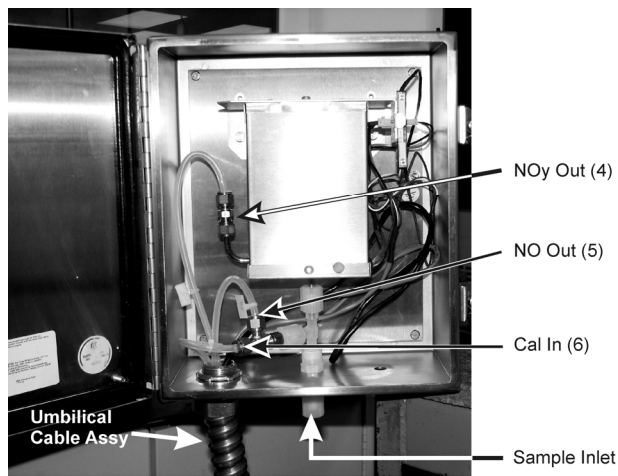
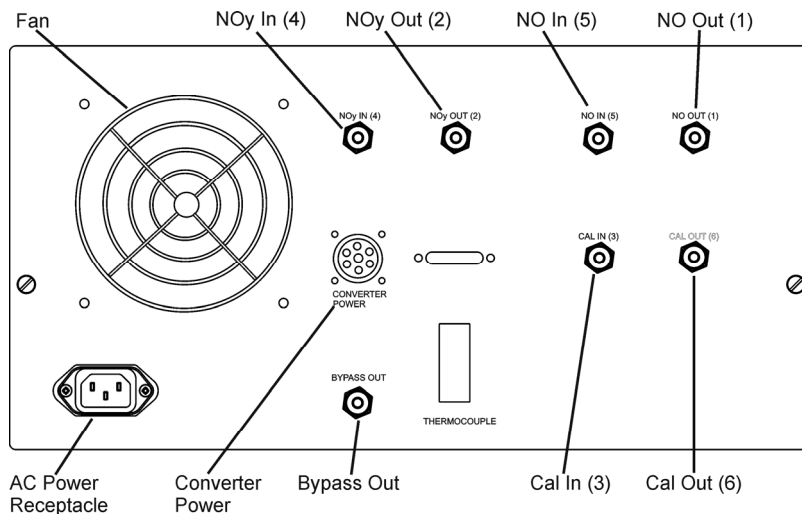
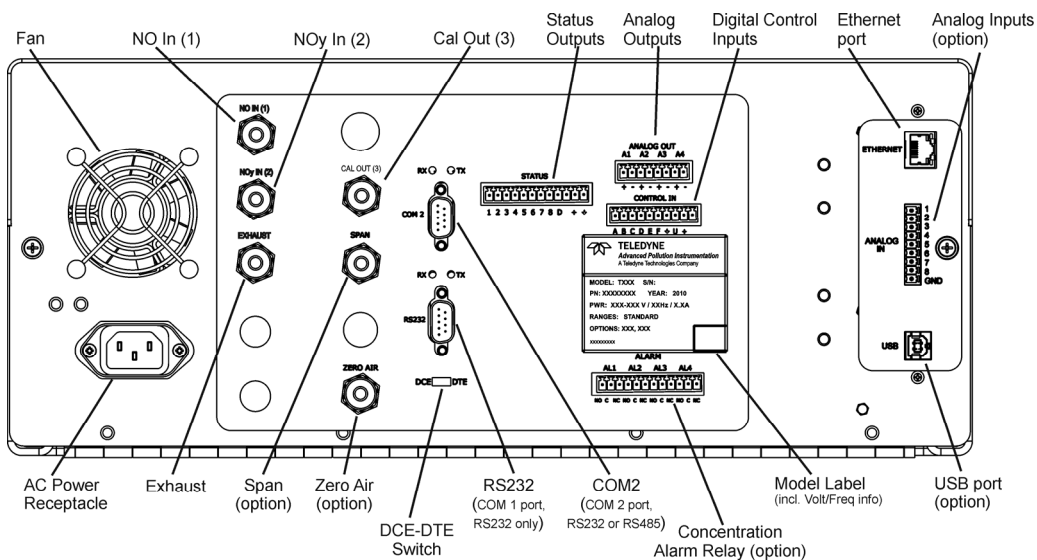
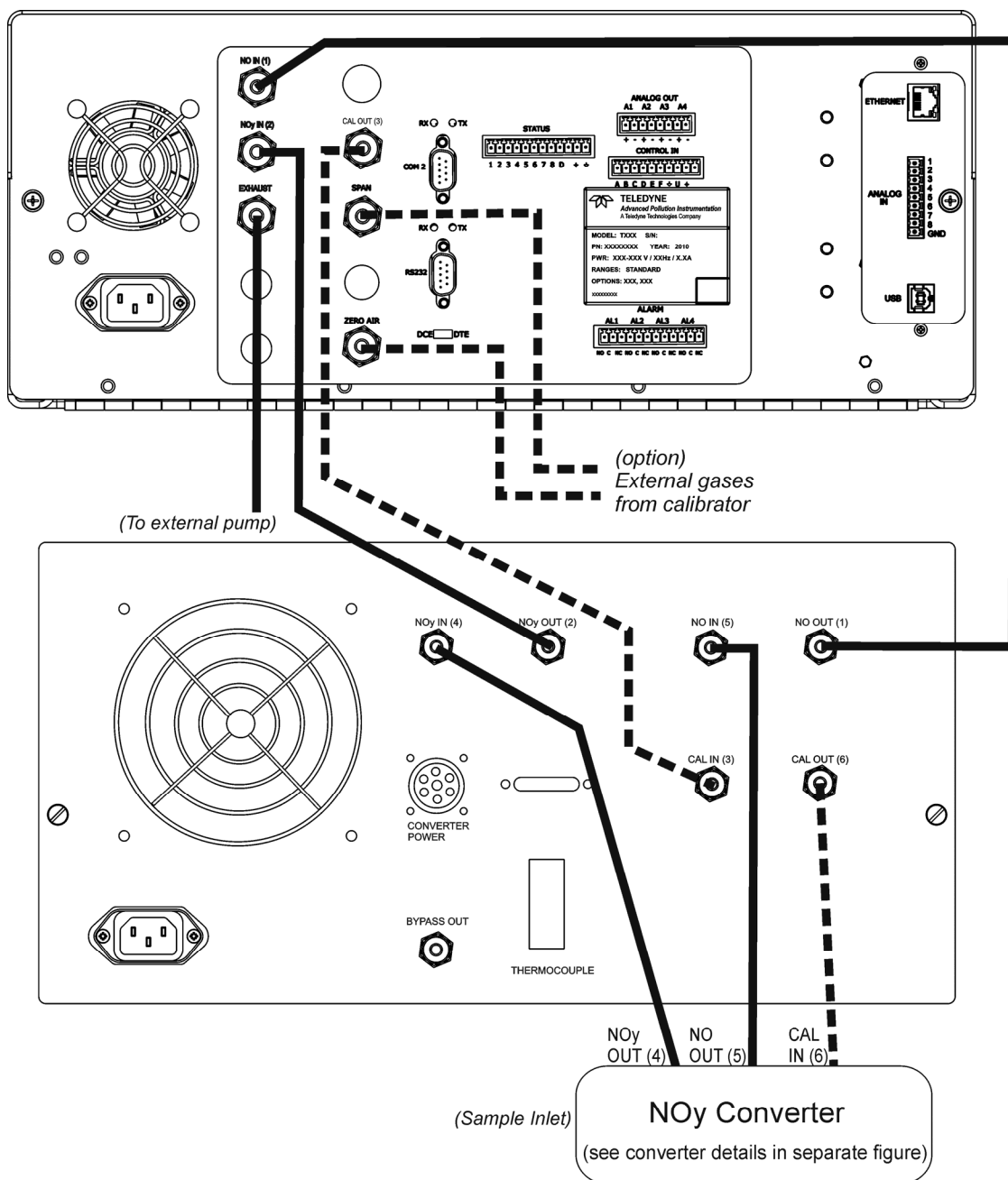

Figure 1. Rear Panels: T200U-NOy Analyzer (top) and 501Y (center); Converter (bottom)



**Figure 2. Rear Panel Pneumatic Connections**

**Note:** Pneumatic tubes and rear panel labels include numbers to facilitate matching connections between instruments.

**Connections from Analyzer to Pump to Converter:**

Analyzer	Pump Chassis	Converter
NO IN (1)	NO OUT (1)	
NOY IN (2)	NOY OUT (2)	
(option) CAL OUT (3)	(option) CAL IN (3)	
	NOY IN (4)	NO OUT (4)
	NO IN (5)	NOY OUT (5)
	(option) CAL OUT (6)	(option) CAL IN (6)

## 2.3 Initial Operation

1. After confirming proper supply voltage, turn on the power to the analyzer and the 501Y bypass pump, and plug in the external Pump. If you are unfamiliar with the T200U-NOy analyzer, we recommend that you read the overview in Section 3 of its operation manual before proceeding.
  - The front panel displays should immediately light as the instruments start up.
  - The 501Y requires about 30 minutes for the external Converter to come up to operating temperature.
  - The T200U-NOy requires about 30 minutes for the ozone generator to start up. During that time the instrument will not respond to span gas.
  - After 30 min, the display on the 501Y front panel should read 315°C, indicating that the external Converter is at operating temperature.
  - Follow the instructions in the T200 Manual and the T200U Addendum to confirm proper operation of the analyzer.
2. Proceed to Section 4 of this manual to perform a Zero/Span check.

**Table 1 Final Test and Calibration Values**

Test Values	Observed Value	Units	Nominal Range
CONVERTER TEMP		°C	315 ±7
BYPASS FLOW – NO CHANNEL		CC/MIN	800 ± 80
BYPASS FLOW – NOy CHANNEL		CC/MIN	800 ± 80

Converter Serial # \_\_\_\_\_

Date \_\_\_\_\_

Technician \_\_\_\_\_

This page intentionally left blank.



## 3.0 SPECIFICATIONS, WARRANTY

### 3.1 Specifications

**Table 2 Specifications for the External Converter and the the 501Y Bypass Pump**

Converter	Remotely mounted molybdenum external Converter with temperature controller in a NEMA – 4 enclosure.
Converter Temperature	315°C ± 7°C with read-out on front panel of bypass pump chassis.
Tube/Electrical Cable Assembly	Up to 50 feet (15 m) maximum length
Power, 501Y Bypass Pump Assembly	120V~ 60 Hz, 230V~ 50 Hz 360 watts
Power, Converter Assembly	120V~ 50/60 Hz, 60 watts
Converter Efficiency	>96% for NO2
Weight, 501Y Bypass Pump Assembly	35 lbs (16 kg)
Weight, Remote Converter	30 lbs (11 kg)
501Y Bypass Pump Chassis Dimensions HxWxD	9" x17" x23.6" (23cm x 43cm x 61cm)
Remote Converter Assy Dimensions HxWxD	12"x19"x7" (31cm x 48cm x 18cm)
Environmental	Installation Category (Over-voltage Category) II Pollution Degree 2
Bypass Flow rate Cal gas Flow rate	800 cc/min ± 10%, each channel 4000 cc/min (approx.)

## **3.2 Warranty**

### **TELEDYNE ADVANCED POLLUTION INSTRUMENTATION, INC.**

*02024c*

Prior to shipment, API equipment is thoroughly inspected and tested. Should equipment failure occur, API assures its customers that prompt service and support will be available.

#### **COVERAGE**

After the warranty period and throughout the equipment lifetime, API stands ready to provide on-site or in-plant service at reasonable rates similar to those of other manufacturers in the industry. All maintenance and the first level of field troubleshooting are to be performed by the customer.

#### **NON-API MANUFACTURED EQUIPMENT**

Equipment provided but not manufactured by API is warranted and will be repaired to the extent and according to the current terms and conditions of the respective equipment manufacturers warranty.

#### **GENERAL**

API warrants each Product manufactured by API to be free from defects in material and workmanship under normal use and service for a period of one year from the date of delivery. All replacement parts and repairs are warranted for 90 days after the purchase.

If a Product fails to conform to its specifications within the warranty period, API shall correct such defect by, in API's discretion, repairing or replacing such defective Product or refunding the purchase price of such Product.

The warranties set forth in this section shall be of no force or effect with respect to any Product:

(i) that has been altered or subjected to misuse, negligence or accident, or (ii) that has been used in any manner other than in accordance with the instruction provided by API or (iii) not properly maintained.

THE WARRANTIES SET FORTH IN THIS SECTION AND THE REMEDIES THEREFORE ARE EXCLUSIVE AND IN LIEU OF ANY IMPLIED WARRANTIES OF MERCHANTABILITY, FITNESS FOR PARTICULAR PURPOSE OR OTHER WARRANTY OF QUALITY, WHETHER EXPRESSED OR IMPLIED. THE REMEDIES SET FORTH IN THIS SECTION ARE THE EXCLUSIVE REMEDIES FOR BREACH OF ANY WARRANTY CONTAINED HEREIN. API SHALL NOT BE LIABLE FOR ANY INCIDENTAL OR CONSEQUENTIAL DAMAGES ARISING OUT OF OR RELATED TO THIS AGREEMENT OF API'S PERFORMANCE HEREUNDER, WHETHER FOR BREACH OF WARRANTY OR OTHERWISE.

#### **TERMS AND CONDITIONS**

*All units or components returned to Teledyne API should be properly packed for handling and returned freight prepaid to the nearest designated Service Center. After the repair, the equipment will be returned, freight prepaid.*

## 4.0 THE T200U-NO<sub>y</sub> EXTERNAL CONVERTER

### 4.1 Principle of Operation

The T-API Model T200U-NO<sub>y</sub> is designed to measure the concentration of NO, NO<sub>2</sub>, and other compounds that are too unstable to be measured when taken in through the normal ambient air sample inlet system. Please refer to the T200U manual supplied with this system for a general discussion of the operation of a NO<sub>x</sub> analyzer. The suite of compounds known collectively as NO<sub>y</sub> is composed of roughly 30 compounds. The NO<sub>y</sub> measurement is generally done in conjunction with a standard NO<sub>x</sub> measurement, with the difference between the two being the concentration of the unstable compounds, sometimes referred to as NO<sub>z</sub>.

The analyzer measures two independent gas streams. One bypasses the external Converter and measures NO in the sample. The other pulls the sample through the external Converter and is displayed as NO<sub>y</sub>. Under normal calibration conditions the NO<sub>y</sub> measurement is equivalent to the delivered NO<sub>x</sub> calibration gases.

The system is composed of four modules:

- The T200U-NO<sub>y</sub> analyzer, without a Moly converter (includes optional Zero/Span valves if ordered).
- A 501Y Bypass Pump containing:
  - bypass pump
  - flow control
  - sample filtration
  - moly temperature control
  - pneumatic provisions for calibration
- Externally mounted molybdenum converter (external Converter)
- External Pump

The T200U-NO<sub>y</sub> system allows the point of sampling to be located in close proximity to the Converter. This configuration provides minimal time delay between the sample inlet and the remotely mounted (~10 meters above ground) external Converter. Minimizing the transit time between the sample inlet and Converter enables the conversion of labile components of NO<sub>y</sub>. The equation for the conversion is:

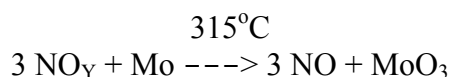

This page intentionally left blank.

## **5.0 CALIBRATION AND ZERO/SPAN (Option) CHECKS**

Unlike most NO<sub>x</sub> analyzers, the T200U-NO<sub>y</sub> does not have a sample inlet port on its rear panel. The sample inlet is located on the external Converter. Also, if a fitting is located at the CAL OUT (3), SPAN and ZERO AIR ports, then the analyzer is equipped with the Zero/Span option.

Follow the steps in the T200U manual to:

- a. Enter the expected NO and NO<sub>y</sub> span gas concentrations in the analyzer.
- b. Do the zero calibration procedure
- c. Do the span calibration procedure

The analyzer always routes the zero/span gas through the external Converter. In standard configuration, the calibration gas needs to be input at the CAL IN (3) port of the 501Y bypass pump. When the Zero/Span valve option is installed, zero and span gases are to be provided at the analyzer ZERO and SPAN ports. In all cases, the calibration gas delivered must be under a small amount of pressure (2-5 psig) to overcome the resistance of the tubing.

### **NOTE**

**There must be no venting of the Zero or Span gas to atmosphere prior to the analyzer. The gases actually vent at the external Converter.**

Calibration gas must be provided for both the 501Y bypass system and the analyzer. Flow requirements are 0.80 LPM for NO bypass, 0.80 LPM for NO<sub>y</sub> bypass and 1 LPM for the analyzer. Calibration gas flow must be in sufficient excess (~4 LPM) to prevent any ambient air from entering the sample inlet of the external Converter.

The maximum 50 ft length of tubing between the 501Y and the remote Converter has been proven to generate too much backpressure for some brands of calibrators. Teledyne calibrators are designed to overcome this potential issue.

We strongly recommend that span calibration be done with NO span gas. Span checks can be done with one of: NO only, NO<sub>2</sub> only, or a mixture of NO and NO<sub>2</sub> (GPT).

Zero air used for all calibration procedures, including GPT, should have <1 ppt NO and NO<sub>2</sub>, less than 1 ppt of major interferents such as SO<sub>2</sub>, NH<sub>3</sub>, hydrocarbons and a dew point of -5°C or less. The calibration gasses should be from a reliable supplier, since the quality of the tank concentration values ultimately determines the accuracy of the analyzer.

**NOTE**  
**The T200U-NOy does NOT have equivalency approval.**

## 5.1 Calibration or Cal Check Procedure

Calibration of the analyzer can be checked or adjusted using gas introduced either through the ZERO and SPAN ports of the analyzer (if option installed) or through the CAL IN (3) port on the 501Y rear panel. The calibration gas is routed to a tee fitting (see CAL IN (6) in **Figure 4**), near the sample inlet on the external Converter assembly.

Since the zero gas concentration is defined as 0 ppb, it is not necessary to enter the expected zero value. **Table 3** details the zero calibration procedure.

**Table 3 Manual Zero Calibration Procedure**

Step Number	Action	Comment
1.	Press CAL	The analyzer enters the calibrate mode.
2.	Wait For Stability Type STB < 0.1 PPB	Wait for reading to stabilize at zero value.
3.	Press ZERO	If you change your mind after pressing ZERO, you can still press EXIT here without zeroing the instrument.
4.	Press ENTR	Pressing ENTR actually changes the calculation equations.
5.	Press EXIT	The analyzer returns to sampling. Immediately after calibration, data is not added to the DAS averages.

**Table 4 Enter Expected Span Gas Concentrations Procedure For NO & NOy**

Step	Action	Comment
1.	Press CAL>CONC>NOy	This menu sequence causes the analyzer to prompt for the expected NOy concentration. Enter the NOy span concentration value by pressing the applicable touchscreen buttons to set the expected value.
2.	Press ENTR	ENTR stores the expected NOy span value.
3.	Press CAL>CONC>NO	Now enter the expected NO span concentration as in step one.
4.	Press ENTR	Pressing ENTR stores the NO span value and returns the prompt to the CONC menu.
5.	Press EXIT	Returns instrument to SAMPLE mode.

If desired, compensation for converter efficiency (CE) can be included in the NOy concentration calculation. Prior to calibration, the converter efficiency should either be set to 1.0 or determined per the procedure in the T200 manual.

**Table 5 Span Calibration Procedure**

Step	Action	Comment
1.	Press CAL	The analyzer enters the calibrate mode.
2.	Wait For Stability Type STB < 2 PPB	Wait for reading to stabilize at span value.
3.	Press SPAN	If you change your mind after pressing SPAN, you can still press EXIT here without spanning the instrument.
4.	Press ENTR	Pressing ENTR actually changes the calculation equations and causes the instrument to read the NO and NOy span concentrations.
5.	Press EXIT	The analyzer returns to sampling. Immediately after calibration, data is not added to the DAS averages.

This page intentionally left blank.



## 6.0 MAINTENANCE

### 6.1 Maintenance Schedule

The schedule for preventative maintenance is presented in Table 6 below.



**Table 6 Preventative Maintenance Calendar**

Item	Maintenance Interval
Zero/Span Calibration	Annually or after maintenance or repairs
Zero/Span Checks	Daily
Particulate Filter	Weekly as needed
Ozone Flow	Check every year and replace o-ring and orifice in reaction cell
Ozone Dryer Filter-DFU	Replace every year
Sample Flow	Check every 2 months
Converter	Check efficiency every 2 months
Pneumatic Lines	Check every 3 months
Factory Calibration	Calibrate each year or after repairs
Leak Check	Check every 6 months
Replace bypass flow orifices	Every year / as needed
Rebuild 501Ybypass pump	Every year (check part number on pump label)

## **6.2 Replacing the Sample Particulate Filters**

The particulate filter should be inspected often for signs of plugging or contamination. It is also common for dirt particles to cause instrument drift, and affect accuracy.

To check and change the filter:

1. Fold down the 501Y front panel.
2. Locate both filters on the left and right side of the 501Y front panel. See Figure 3 for an exploded view of the filter assembly.
3. Visually inspect the filter through the glass window.
4. If the filter appears dirty, unscrew the hold-down ring, remove the Teflon o-ring and then the filter.
5. Replace the filter, being careful that the element is fully seated in the bottom of the holder. Replace the Teflon o-ring, then screw on the hold-down ring and hand tighten.

**NOTE:**

**Handle the wetted surfaces as little as possible and clean with cloth prior to assembly**

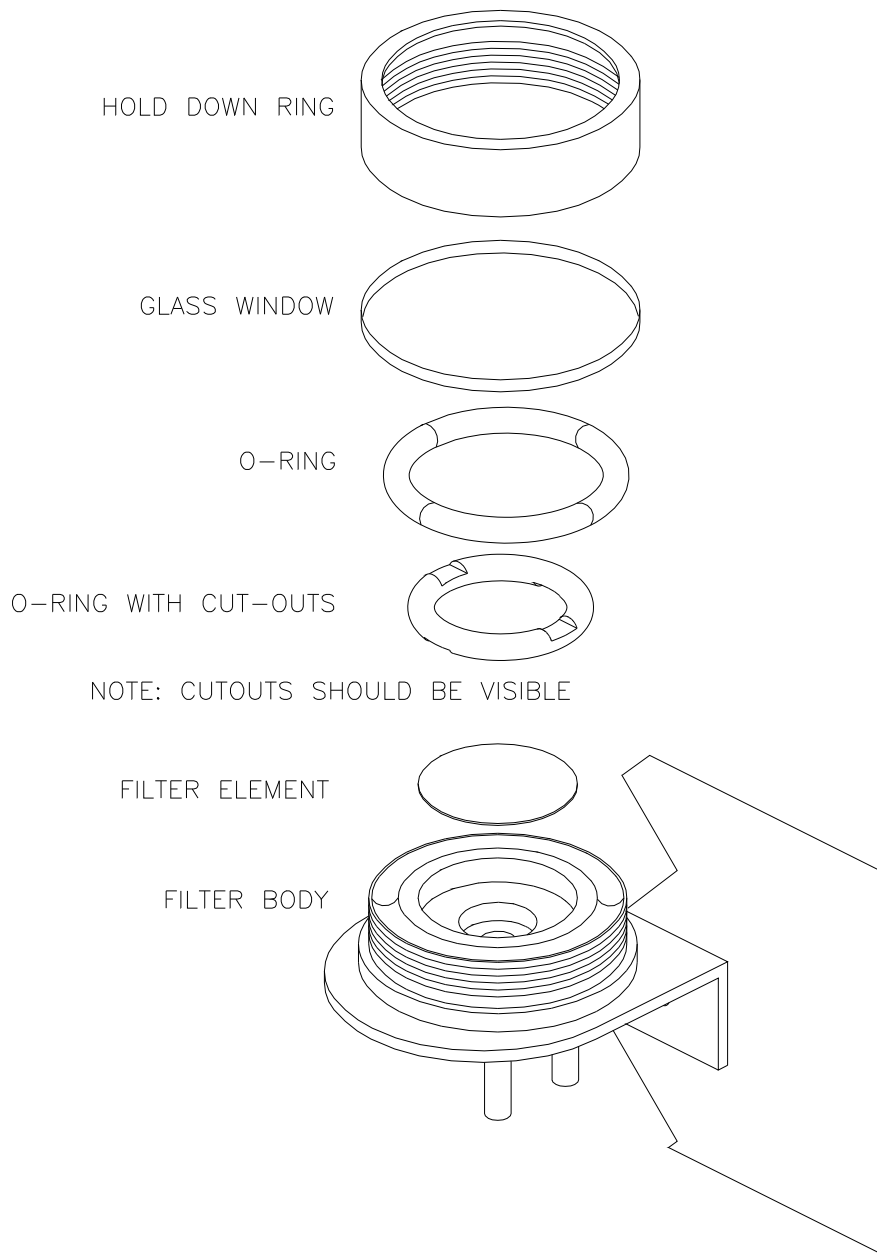

**Figure 3 Replacing the Particulate Filter**

## 6.3 Checking Analyzer Flow Rate

The external Pump is capable of maintaining the reaction cell pressure at less than 5.0 In-Hg-A. If a higher pressure is noted, the Pump may need servicing. Check the Pump and pneumatic system for leaks or rebuild the Pump.

### CAUTION!



Never operate the analyzer without the ozone destruct component properly seated and connected within the pneumatic path. The ozone destruct is integrated into the converter case, at the exhaust of the reaction cell, inside the instrument.

The sample flow as measured at ports NO IN (1) and NOy IN (2) at the rear of the analyzer should be  $1000 \pm 100$  cc/min.

See Figure 1 for component locations.

## 6.4 Replacing the Converter

The heater, thermocouple, and converter guts assembly is designed to be replaced as a single unit. Check Figure 4 for the assembly location.

### CAUTION!



The converter operates at 315°C. Severe burns can result if not enough time is allowed for the assembly to cool. Do not handle assembly until it is at room temperature.

1. Turn off the power to the 501Y at its front panel ON/OFF switch.
2. Allow the external Converter to cool.
3. Disconnect the gas fittings and power cable from the internal box containing the heater, thermocouple and converter guts assembly (**Figure 4**).
4. Remove the entire box from the Converter shelter.
  - a. Remove the pneumatic fittings.
  - b. Remove the guts assembly box from the chassis by loosening the 4 captive screws that secures the assembly to the chassis.
5. Remove bottom bracket and re-attach it to the replacement guts assembly.
6. Install the box with guts assembly back into the analyzer.
7. Re-attach the electrical and pneumatic fittings. Leak check the assembly when completed.
8. Turn the 501Y power back on. The insulation can emit a burnt odor for the first 24 hours; this is normal. Allow the Converter to burn-in for 24 hours, then re-calibrate the instrument.

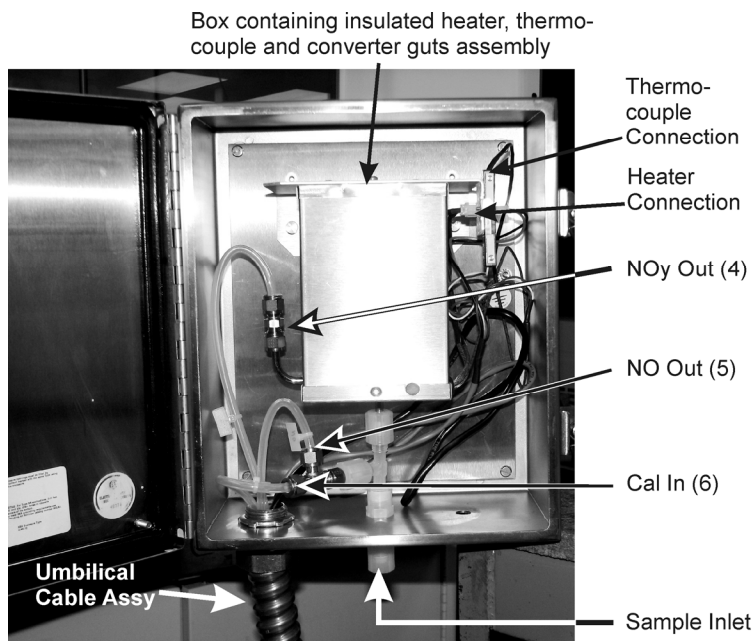

**Figure 4 NOy Converter Guts Assembly Location**

## ***6.5 Inspecting Pneumatic Lines***

Particulate matter in the pneumatic lines will affect both flow rate and response time. It is important that the pneumatic system be periodically inspected and thoroughly cleaned if necessary. Clean by disassembling and passing methanol through three times. Dry with clean zero air.

Also inspect all pneumatic lines for cracks and abrasion on a regular basis. Replace as necessary.

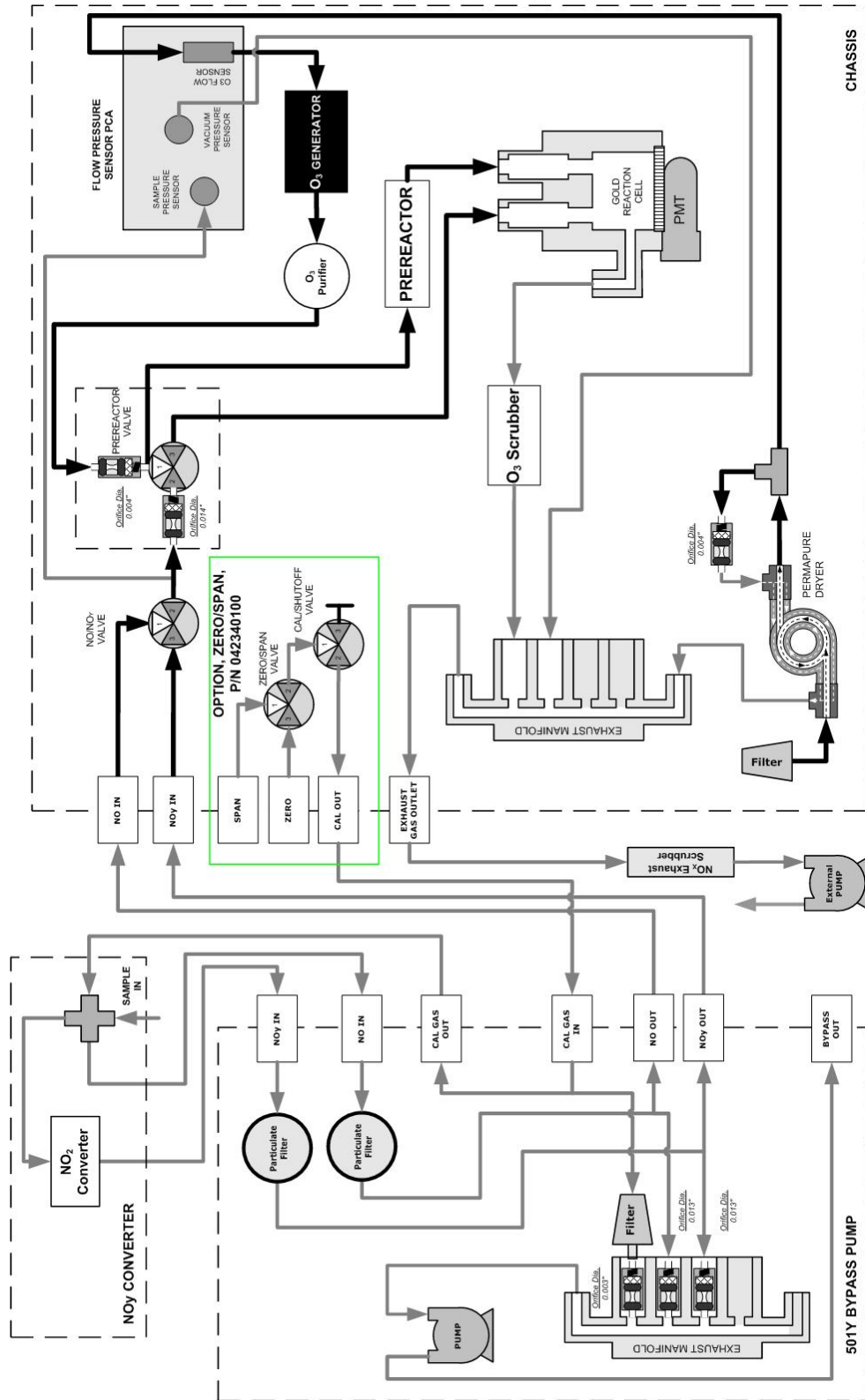

Figure 5. Pneumatics Diagram

## 6.6 Checking for Leaks

If a leak checker is not available, it is possible to leak check the instrument using the sample pump plus a shut-off valve.

1. Turn off power to the analyzer and the 501Y, and unplug the external Pump.
2. Cap the sample inlet of the external Converter, the BYPASS OUT port of the 501Y, the ozone generator air inlet (located inside the analyzer, Figure 6), and the analyzer rear panel ZERO AIR/SPAN ports (if Z/S valve option present).

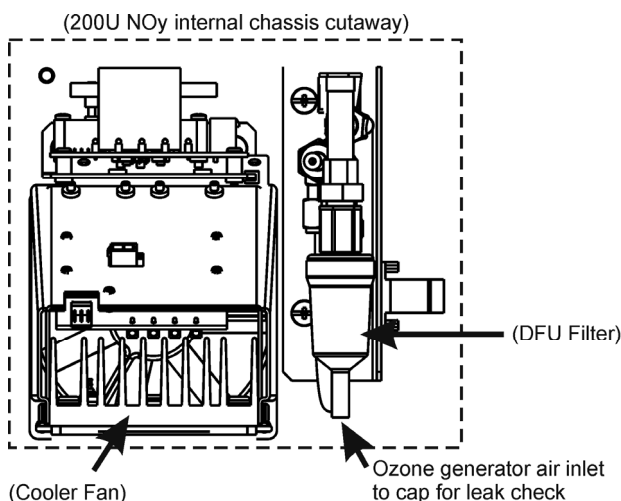



Figure 6 Location of O<sub>3</sub> Generator Air Inlet

3. Insert a shut-off valve between the external Pump and the EXHAUST port at the rear of the analyzer.
4. Turn on the analyzer power and plug in the external Pump. Set the TEST function to RCEL, which measures the reaction cell pressure. Close the shutoff valve and monitor the cell pressure. The pressure should not increase more than 1"Hg (.5psi) in 5 minutes. If there is a leak, you'll need to locate it by using a pressure leak checker described below.

If you have a leak checker:

1. Turn off power to the analyzer and 501Y, and unplug the external Pump.
2. Disconnect the external Pump from the analyzer's rear panel. Cap the sample inlet of the external Converter, the BYPASS OUT port of the 501Y, the ozone generator air inlet (located inside the analyzer, Figure 6), and the analyzer rear panel ZERO AIR/SPAN ports (if Z/S valve option present), and connect the leak checker to the instrument exhaust port.

	<p><b>CAUTION!</b></p> <p>Pressure must be less than 15 PSI.</p>
---	--



3. Pressurize the system and check for leaks by watching overall pressure. The pressure should not drop more than 1"Hg (.5psi) in 5 minutes.

If the instrument fails the pressure test, each fitting needs to be leak checked to find the location.

NOTE

Be careful that the system is always pressurized so as not to draw soap solution into the plumbing system. Make sure you dry off any accumulated bubble solution. Start by checking the external fittings first.

This page intentionally left blank.

## 7.0 TROUBLESHOOTING, ADJUSTMENTS



### CAUTION!

The operations outlined in this section must be performed by qualified maintenance personnel only!

This section of the manual contains information on diagnosing and repairing instrument performance problems. It provides troubleshooting procedures that address problems to the board level.

As a guide to troubleshooting, think of the T200U-NOy as two systems:  
Pneumatics and Electronics.

- Pneumatics - Over 50% of all instrument problems are traced to pneumatic leaks. Suspect a leak first.
- Electronics – external Converter temp control board or DC power supply for the converter temperature readout.

Another trouble-shooting tip has to do with incorrect span gas concentration:

- This could come either from the calibrator itself or from incorrectly entering the expected span gas concentration in the instrument.
- If the instrument does not respond to span gas, check troubleshooting section in the T200 manual.

The above should get you started in diagnosing and repairing the most common faults. If these reasons have been eliminated and there are still problems with the unit, the next thing to do is a Factory Calibration covered in the T200 manual. If difficulties persist, contact our service department. The 800 telephone number is on the cover page of this manual.

## 7.1 Operation Verification – Diagnostic Techniques

### 7.1.1 Pneumatic System

**Figure 7** illustrates the pneumatics of the analyzer, 501Y bypass pump and Converter system.

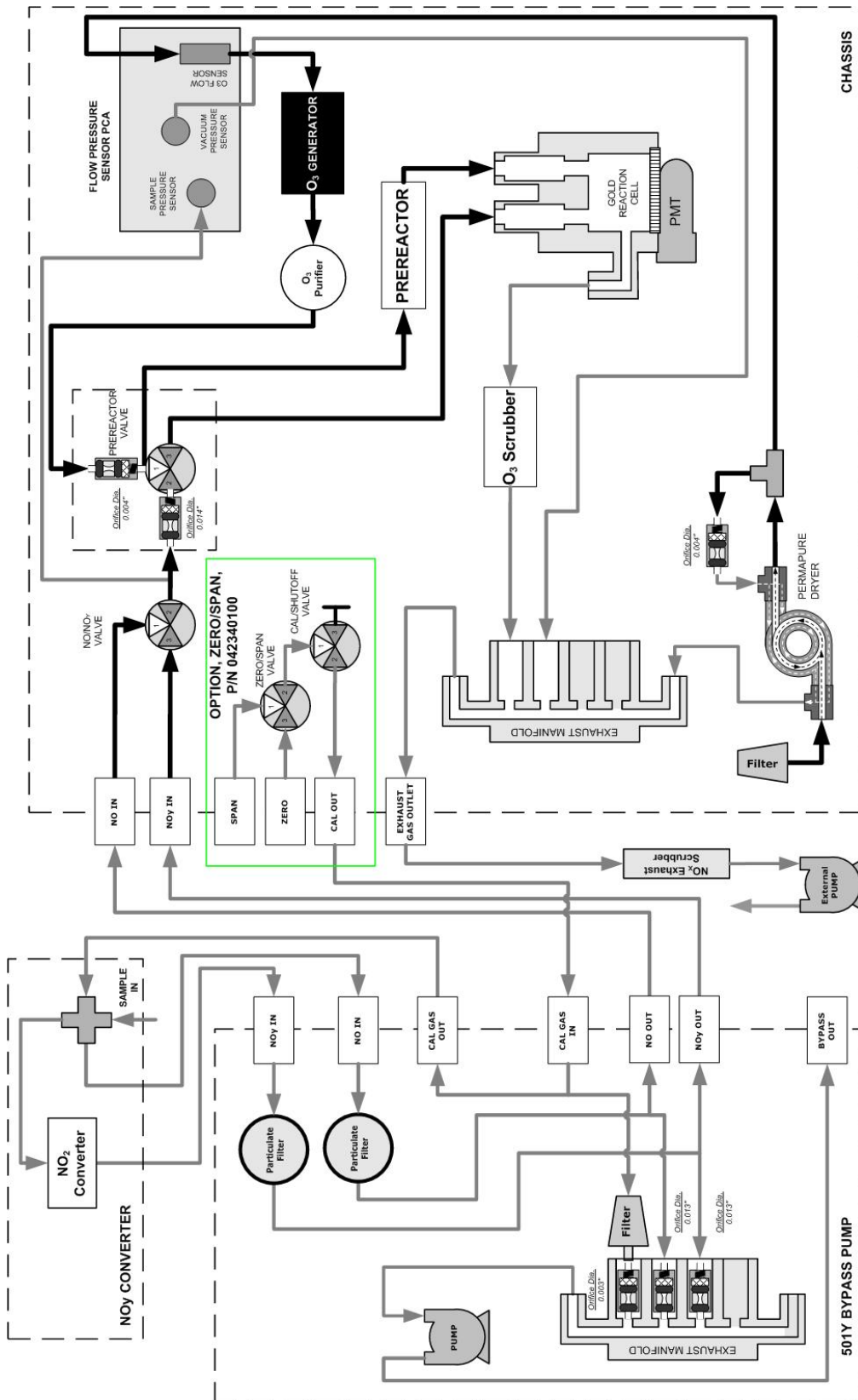

Figure 7 Pneumatic Diagram

### **7.1.2 Leak Check**

Refer to Section 5.6 for the leak check procedure.

### **7.1.3 501Y Bypass Pump Diagnostic Procedures**

The 501Y bypass pump is capable of maintaining a total bypass flow rate of ~2.2 lpm. If flow checks indicate a fall off in bypass flow, the pump may need servicing. Check the pump, inlet fittings, and analyzer for leaks first. If other causes have been eliminated, rebuild the pump.

### **7.1.4 Electrical Fault Isolation**

115 VAC is supplied to:

- the bypass pump
- the +5 volt and +24 volt switcher supplies
- the input power to the converter temperature controller

Refer to Figure 8 to check the 115 VAC supply voltage to each of these components.

The converter temperature is controlled by the FUJI controller located on the 501Y front panel.

The controller cycles power to the external converter, thereby maintaining the temperature at 315 °C, using the solid state relay.

## **7.2 Setting the Converter Temperature**

A front panel-mounted programmable controller maintains the temperature of the remote external Converter. By pressing the PV/SV button in the lower left corner of the controller, you can see the Present Value (actual temperature) or the Set Value (temperature set point). The temperature and PID (proportional, integral and derivative) control parameters have been set at the factory and no further adjustment should be necessary. Should you need to adjust the temperature, follow these steps:

1. Select **SV** with the PV/SV button.
2. Press the "up-arrow" under the digit you want to change (the digit will flash),
3. Press the "up-arrow" under the digit or the "down-arrow" at the left to scroll the digit to the desired value.
4. Repeat for the other two digits.
5. Press the ENTER button.
6. Select **PV** with the PV/SV button to observe the actual temperature.

### 7.2.1 Temperature Controller Setup

The FUJI temperature controller has been programmed at the factory and should not need to be altered under normal usage.

Indications that would require re-programming are:

- Failure / replacement of controller.
- Replacement of thermocouple element.
- Controller's loss of PID parameters leading to instability of the temp setpoint.

In the event that the control parameters are changed or in the event that a new controller is installed, it must be reprogrammed to suit the thermal characteristics of the instrument. The controller includes an Autotuning feature, which can be used to properly set the PID factors.

To start the Autotune procedure:

1. Press SEL until A7 (AT) is displayed
2. Press Data until value = 1 (enable Autotune)
  - While Autotuning, the decimal point LED will blink.
  - NOTE: During the procedure, it is normal for the temp to overshoot up to 100°C.
  - When the decimal point LED turns off, Autotune is complete. No further adjustment should be necessary.

**Table 7 Temperature Controller Programming Guide**

PRESS	DISPLAY	ACTION
SEL DATA	<b>P</b> PROP BAND	UP/DOWN SET TO 5.0 (ENTER)
SEL DATA	<b>i</b> INTEGRAL	SET TO 50
SEL DATA	<b>d</b> DERIVATIVE TIME	SET TO 15
SEL DATA	<b>AL</b> LOW ALARM SETP	SET TO 300
SEL DATA	<b>AH</b> HIGH ALARM SETP	SET TO 330
SEL DATA	<b>7C</b> CYCLE TIME	SET TO 2 (FOR FAST SYSTEM)
SEL	<b>HYS</b> HYSTERESIS	SET TO 0.3
SEL	<b>LOC</b> LOCK	0 = OPEN 1 = LOCKED 2 = SV ONLY OPEN

**NOTE:**  
**DO NOT SET THE TEMPERATURE (SV) HIGHER THAN 320°C.**

SECONDARY MENU (The fixed characteristics of the system).

<b>PRESS</b>	<b>DISPLAY</b>	<b>ACTION</b>
SEL <i>hold until</i>	<b>p-n1</b>	SET TO 0 – REVERSE ACTION
SEL <i>hold until</i>	<b>p-n2</b>	SET TO 2 = TYPE J THERMOCOUPLE
SEL	<b>p-dF</b> DIGITAL FILTER	SET TO 5
SEL	<b>P-SL</b> LOWER LIMIT	SET TO -40 (-40°C)
SEL	<b>P-SU</b> UPPER LIMIT	SET TO 350 (350°C)
SEL	<b>P-AH</b> ALARM	SET TO 0
SEL	<b>P-An</b> HYTERESIS	SET TO 5
SEL	<b>P-dP</b> PROG DECIMAL	SET TO 0
SEL	<b>PVOF</b> PROCESS OFFSET	LEAVE AT 0
SEL	<b>SVOF</b> SET POINT OFFS	LEAVE AT 0
SEL	<b>P-F</b>	SET TO 0 (0 = °C, 1 = °F)
SEL	<b>P-n1</b>	ALREADY CONFIGURED
SEL <i>hold until</i>	RETURNS TO MAIN MENU	
SEL	<b>PV/SV</b>	SET DISPLAY TO 315 °C
SEL <i>hold until</i>	<b>P</b> PROP BAND	ALREADY CONFIGURED
SEL	SCROLL TO <b>A7</b>	SET TO 1 (AUTOTUNE )

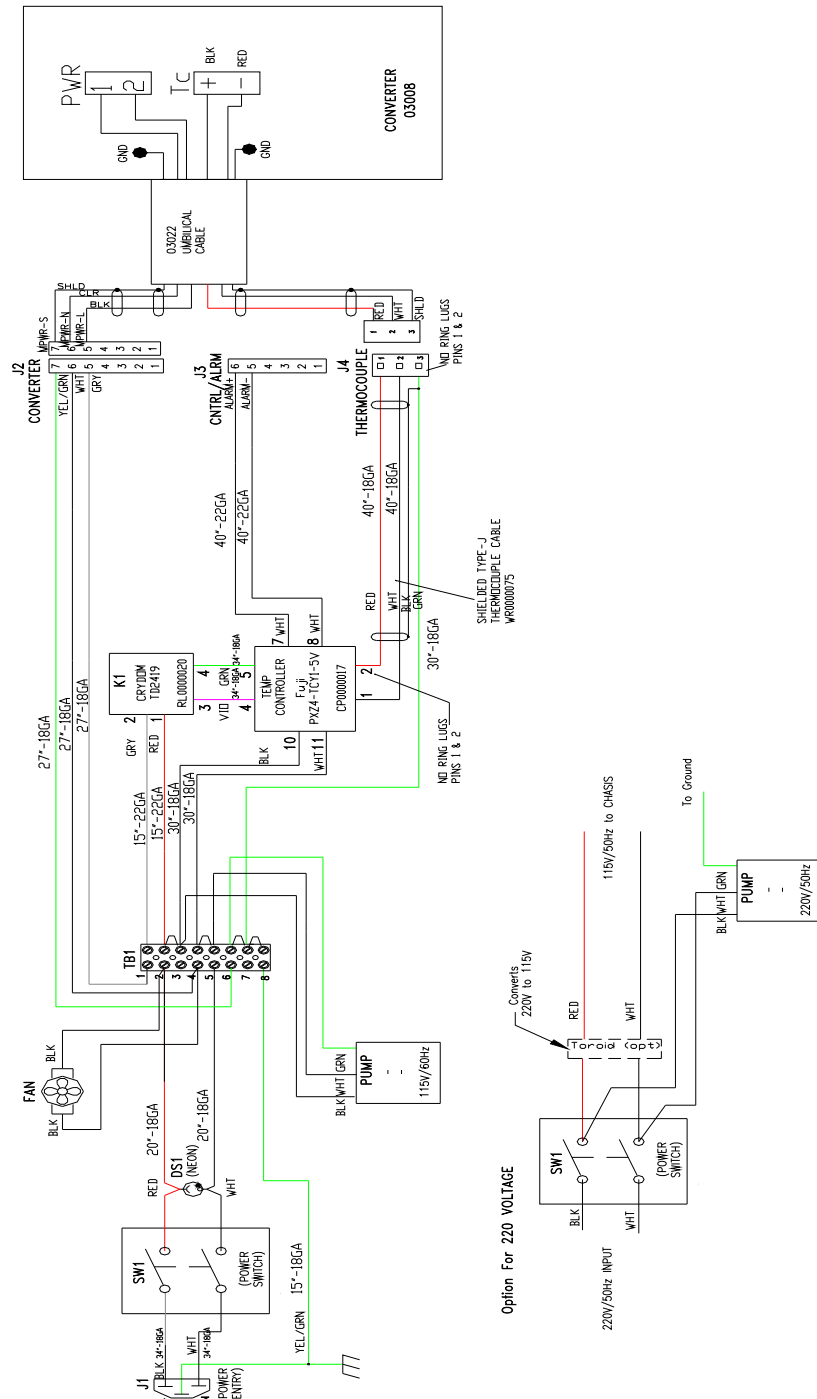

Figure 8 Electrical Diagram



## 8.0 T200U-NOY SPARE PARTS LIST

The following spare parts list supplements the spare parts list for the T200U analyzer.

Note
Use of replacement parts other than those supplied by API may result in non-compliance with European Standard EN 61010-1.

Note
Due to the dynamic nature of part numbers, please refer to the TAPI Website at <a href="http://www.teledyne-api.com">http://www.teledyne-api.com</a> or call Customer Service at 800-324-5190 for more recent updates to part numbers.

Reference: 06848 11/8/2010 1:13:10 PM	
PARTNUMBER	DESCRIPTION
000940100	CD, ORIFICE, .003 GREEN
000940400	CD, ORIFICE, .004 BLUE
000941100	CD, ORIFICE, .014 ORG/VIOLET
001330001	SLEEVE, GOLD PLATED, NOX
001761800	ASSY, FLOW CTL, 90CC, 1/4" TEE-TMT, B
002270100	AKIT, GASKETS, WINDOW, (12 GASKETS = 1)
002730000	CD, FILTER, 665NM (KB)
004330000	ZERO AIR SCRUBBER (NO/NO2)
005960000	AKIT, EXP, 6LBS ACT CHARCOAL (2 BT=1)
005970000	AKIT, EXP, 6LB PURAFIL (2BT=1)
009690200	AKIT, TFE FLTR ELEM (FL19,100=1) 47mm
009690300	AKIT, TFE FLTR ELEM (FL19, 30=1) 47mm
011310000	ASSY, DRYER, NOX
011630000	HVPS INSULATOR GASKET (KB)
013140000	ASSY, COOLER FAN (NOX/SOX)
014030000	AKIT, NOX EXPENDABLES, IZS
014080200	ASSY, HVPS, NOX
016290000	WINDOW, SAMPLE FILTER, 47MM (KB)
016300900	ASSY, SAMPLE FILTER, 47MM, ANG BKT, 5UM
024600100	ASSY, PREREACTION NO/NOX VALVE
024930000	CD, PMT, NOX
037860000	ORING, TEFLON, RETAINING RING, 47MM (KB)
039700100	HEATER, BAND, TYPE K, DUAL VOLTAGE(KB)
040010000	ASSY, FAN REAR PANEL
040030800	PCA, PRESS SENSORS (2X), FLOW, (NOX)
040400000	ASSY, HEATERS/THERMAL SWITCH, RX CELL
040410500	ASSY, VACUUM MANIFOLD
040420200	ASSY, O3 GEN BRK, HIGH-O/P
041510200	ASSY, PRESS/FLOW SENSOR, NOX
041800300	PCA, PMT PREAMP, (OBS)

Reference: 06848 11/8/2010 1:13:10 PM	
PARTNUMBER	DESCRIPTION
041800600	PCA, PMT PREAMP, VR,
041920000	ASSY, THERMISTOR
042340100	OPTION, ZERO/SPAN VALVES, (KB)
042680100	ASSY, VALVE (SS)
043420000	ASSY, HEATER/THERM, O2 SEN
044340000	ASSY, HTR, BYPASS MANIFOLD
044540000	ASSY, THERMISTOR, NOX
044600000	AKIT, SPARES, NOX
045230100	PCA, RELAY CARD
045230200	PCA, RELAY CARD
045430000	ASSY, DRYER, O3, W/RELAYS & BRKT *
04550010A	ASSY, ORIFICE HOLDER, 4 MIL
04550030A	ASSY, ORIFICE HOLDER, 10 MIL, (NOX) (KB)
045500400	ASSY, ORIFICE HOLDER, 3 MIL
046030000	AKIT, CH-43, 3 REFILLS
046480000	ASSY, DILUTION MANIFOLD, (KB)
046490000	OPTION, DILUTION MANIFOLD (KB)
047150000	AKIT, EXPENDABLES, NOX
049310100	PCA,TEC DRIVER,PMT,(KB)
049760300	ASSY, TC PROG PLUG, MOLY,TYP K, TC1
050700200	KIT, RELAY BD NOX CONFIGURATION
051210000	DESTRUCT w/FTGS, O3 *
051990000	ASSY, SCRUBBER, INLINE EXHAUST, DISPOS
052820000	ASSY, IZS, HEATER/THERM, NOX
052930200	ASSY, BAND HEATER TYPE K, NOX
055300000	AKIT, PUMP REBUILD, THOMAS 2688, DUAL HD
055740000	ASSY, PUMP, NOx PUMP PACK, 115V/60HZ
055740100	ASSY, PUMP, NOx PUMP PACK, 220V/60HZ
055740200	ASSY, PUMP, NOx PUMP PACK, 220V/50HZ
056490000	FILTER, DFU, DESORBER (SOAKED)
058021100	PCA, MOTHERBD, GEN 5-ICOP
058230000	ASSY, O3 CLEANSER, ALUMINUM
059940000	OPTION, SAMPLE GAS CONDITIONER, NOX*
062390000	ASSY, MOLY GUTS w/WOOL
064540000	ASSY, PUMP NOX INTERNAL, 115V/60HZ
064540100	ASSY, PUMP NOX INTERNAL, 230V/60HZ
064540200	ASSY, PUMP NOX INTERNAL, 230V/50HZ
066970000	PCA, INTRF. LCD TOUCH SCRN, F/P
067240000	CPU, PC-104, VSX-6154E, ICOP *
067300000	PCA, AUX-I/O BD, ETHERNET, ANALOG & USB
067300100	PCA, AUX-I/O BOARD, ETHERNET
067300200	PCA, AUX-I/O BOARD, ETHERNET & USB
067900000	LCD MODULE, W/TOUCHSCREEN
068250100	DOM, w/SOFTWARE, STD, T200U *
068810000	PCA, LVDS TRANSMITTER BOARD
069500000	PCA, SERIAL & VIDEO INTERFACE BOARD
072150000	ASSY. TOUCHSCREEN CONTROL MODULE
072820000	KIT, T200U MANUAL

Reference: 06848 11/8/2010 1:13:10 PM

<b>PARTNUMBER</b>	<b>DESCRIPTION</b>
CN0000073	POWER ENTRY, 120/60 (KB)
FL0000001	FILTER, SS (KB)
FL0000003	FILTER, DFU (KB)
FM0000004	FLOWMETER (KB)
FT0000010	CONNECTOR-ORING, SS, 1/8" (HK)
HW0000005	FOOT
HW0000020	SPRING
HW0000030	ISOLATOR
HW0000036	TFE TAPE, 1/4" (48 FT/ROLL)
HW0000099	STANDOFF, #6-32X.5, HEX SS M/F
HW0000101	ISOLATOR
HW0000453	SUPPORT, CIRCUIT BD, 3/16" ICOP
KIT000051	AKIT, REBUILD, RX CELL AMBIENT
KIT000095	AKIT, REPLACEMENT COOLER
KIT000115	OPTION, SAMPLE GAS COND, (KB)
KIT000156	OPTION, CARRYING HANDLE
KIT000253	ASSY & TEST, SPARE PS37
KIT000254	ASSY & TEST, SPARE PS38
OR0000001	ORING, 2-006VT *(KB)
OR0000002	ORING, 2-023V
OR0000025	ORING, 2-133V
OR0000027	ORING, 2-042V
OR0000034	ORING, 2-011V FT10
OR0000039	ORING, 2-012V
OR0000044	ORING, 2-125V
OR0000046	ORING, 2-019V
OR0000083	ORING, 105M, 1MM W X 5 MM ID, VITON
OR0000086	ORING, 2-006, CV-75 COMPOUND(KB)
OR0000094	ORING, 2-228V, 50 DURO VITON(KB)
PU0000047	PUMP, THOMAS 2688VE44, 2 HEAD, 115V/60HZ
PU0000048	PUMP, THOMAS 2688VGH144, 230V 50/60HZ CE
PU0000083	KIT, REBUILD, PU80, PU81, PU82
RL0000015	RELAY, DPDT, (KB)
SW0000025	SWITCH, POWER, CIRC BREAK, VDE/CE *(KB)
WR0000008	POWER CORD, 10A(KB)