



TELEDYNE
ADVANCED POLLUTION INSTRUMENTATION
Everywhereyoulook™

USER MANUAL

MODELS T703 and T703U ***PHOTOMETRIC O₃ CALIBRATOR***

© TELEDYNE ADVANCED POLLUTION INSTRUMENTATION (TAPI)
9480 CARROLL PARK DRIVE
SAN DIEGO, CALIFORNIA 92121-5201
USA

Toll-free Phone: 800-324-5190
Phone: 858-657-9800
Fax: 858-657-9816
Email: api-sales@teledyne.com
Website: <http://www.teledyne-api.com/>

NOTICE OF COPYRIGHT

© 2010-2015 Teledyne Advanced Pollution Instrumentation, Inc. All rights reserved.

TRADEMARKS

All trademarks, registered trademarks, brand names or product names appearing in this document are the property of their respective owners and are used herein for identification purposes only.

This page intentionally left blank.

SAFETY MESSAGES

Important safety messages are provided throughout this manual for the purpose of avoiding personal injury or instrument damage. Please read these messages carefully. Each safety message is associated with a safety alert symbol, and placed throughout this manual and inside the instrument. The symbols with messages are defined as follows:



WARNING: Electrical Shock Hazard



HAZARD: Strong oxidizer



GENERAL WARNING/CAUTION: Read the accompanying message for specific information.



CAUTION: Hot Surface Warning



Do Not Touch: Touching some parts of the instrument without protection or proper tools could result in damage to the part(s) and/or the instrument.



Technician Symbol: All operations marked with this symbol are to be performed by qualified maintenance personnel only.



Electrical Ground: This symbol inside the instrument marks the central safety grounding point for the instrument.

CAUTION



This instrument should only be used for the purpose and in the manner described in this manual. If you use this instrument in a manner other than that for which it was intended, unpredictable behavior could ensue with possible hazardous consequences.

NEVER use a gas analyzer to sample any combustible gas(es)!

Note

Technical Assistance regarding the use and maintenance of this instrument or any other Teledyne API product can be obtained by contacting Teledyne API's Technical Support Department:

Telephone: 800-324-5190

Email: sda_techsupport@teledyne.com

or by accessing various service options on our website at <http://www.teledyne-api.com/>

CONSIGNES DE SÉCURITÉ

Des consignes de sécurité importantes sont fournies tout au long du présent manuel dans le but d'éviter des blessures corporelles ou d'endommager les instruments. Veuillez lire attentivement ces consignes. Chaque consigne de sécurité est représentée par un pictogramme d'alerte de sécurité; ces pictogrammes se retrouvent dans ce manuel et à l'intérieur des instruments. Les symboles correspondent aux consignes suivantes :



AVERTISSEMENT : Risque de choc électrique



DANGER : Oxydant puissant



AVERTISSEMENT GÉNÉRAL / MISE EN GARDE : Lire la consigne complémentaire pour des renseignements spécifiques



MISE EN GARDE : Surface chaude



Ne pas toucher : Toucher à certaines parties de l'instrument sans protection ou sans les outils appropriés pourrait entraîner des dommages aux pièces ou à l'instrument.



Pictogramme « technicien » : Toutes les opérations portant ce symbole doivent être effectuées uniquement par du personnel de maintenance qualifié.



Mise à la terre : Ce symbole à l'intérieur de l'instrument détermine le point central de la mise à la terre sécuritaire de l'instrument.

MISE EN GARDE



Cet instrument doit être utilisé aux fins décrites et de la manière décrite dans ce manuel. Si vous utilisez cet instrument d'une autre manière que celle pour laquelle il a été prévu, l'instrument pourrait se comporter de façon imprévisible et entraîner des conséquences dangereuses.

NE JAMAIS utiliser un analyseur de gaz pour échantillonner des gaz combustibles!

WARRANTY

WARRANTY POLICY (02024G)

Teledyne Advanced Pollution Instrumentation (TAPI), a business unit of Teledyne Instruments, Inc., provides that:

Prior to shipment, TAPI equipment is thoroughly inspected and tested. Should equipment failure occur, TAPI assures its customers that prompt service and support will be available.

COVERAGE

After the warranty period and throughout the equipment lifetime, TAPI stands ready to provide on-site or in-plant service at reasonable rates similar to those of other manufacturers in the industry. All maintenance and the first level of field troubleshooting are to be performed by the customer.

NON-TAPI MANUFACTURED EQUIPMENT

Equipment provided but not manufactured by TAPI is warranted and will be repaired to the extent and according to the current terms and conditions of the respective equipment manufacturer's warranty.

PRODUCT RETURN

All units or components returned to Teledyne API should be properly packed for handling and returned freight prepaid to the nearest designated Service Center. After the repair, the equipment will be returned, freight prepaid.

The complete Terms and Conditions of Sale can be reviewed at http://www.teledyne-api.com/terms_and_conditions.asp



CAUTION – Avoid Warranty Invalidation

Failure to comply with proper anti-Electro-Static Discharge (ESD) handling and packing instructions and Return Merchandise Authorization (RMA) procedures when returning parts for repair or calibration may void your warranty. For anti-ESD handling and packing instructions please refer to the manual, Fundamentals of ESD, PN 04786, in its "Packing Components for Return to Teledyne API's Customer Service" section. The manual can be downloaded from our website at <http://www.teledyne-api.com> under Help Center > Product Manuals in the Special Manuals section; RMA procedures are under Help Center > Return Authorization.

ABOUT THIS MANUAL

Presented here is information regarding the documents that are included with this manual (Structure), its history of release and revisions (Revision History), how the content is organized (Organization), and the conventions used to present the information in this manual (Conventions Used).

STRUCTURE

This T703/T703U manual, PN 07223, is comprised of multiple documents, assembled in PDF format, as listed below.

Part No.	Rev	Name/Description
07223	D	T703 and T703U Photometric Calibrator Operation Manual (the main body of this manual)
05745	F	Menu trees and software documentation (inserted as Appendix A of this manual)
07224	A	T703 Spare Parts List (located in Appendix B of this manual)
07747	A	T703U Spare Parts List (located in Appendix B of this manual)
05747	E	Appendix C, Repair Questionnaire

Documents and Schematics included in Appendix D of this manual:

073600100	A	T703 Interconnect List
07360	A	T703 Interconnect Diagram
04354	D	SCH, PCA 04003, PRESS/FLOW
04420	B	SCHEMATIC, UV DET PREAMP
04421	A	SCHEMATIC, UV LAMP SUPPLY
04422	A	SCHEMATIC, DC HEATER/THERMISTOR
04524	E	SCHEMATIC, RELAY CARD
05803	B	SCH, PCA 05802, MOTHERBOARD, GEN-5
06698	D	SCH, PCA 06697, INTRFC, LCD TCH SCRN
06882	B	SCH, LVDS TRANSMITTER BOARD
06731	A	SCH, AUXILLIARY-I/O BOARD

Note

We recommend that this manual be read in its entirety before any attempt is made to operate the instrument.

TABLE OF CONTENTS

1. INTRODUCTION	15
1.1. T703/T703U Calibrator Overview	15
1.2. Options	16
2. SPECIFICATIONS AND APPROVALS	17
2.1. Specifications	17
2.2. Approvals and Certifications.....	18
2.2.1. Safety	18
2.2.2. EMC.....	18
2.2.3. Other Type Certifications.....	18
3. GETTING STARTED	19
3.1. Unpacking and Initial Setup.....	19
3.1.1. Front, Rear, and Internal Calibrator Description	20
3.2. Electrical Connections	28
3.2.1. Power Connection	28
3.2.2. Analog output Test Channel Connections.....	28
3.2.3. Connecting the Status Outputs	29
3.2.4. Connecting the Control Inputs.....	30
3.2.5. Connecting the Control Outputs	32
3.2.6. Communication Connections	33
3.2.6.1. Ethernet Connection	33
3.2.6.2. USB Option Connection.....	33
3.2.6.3. RS-232 and RS485 Connection.....	33
3.2.6.4. Multidrop Network Connection.....	33
3.3. Pneumatic Connections.....	34
3.3.1. Dry Air In.....	34
3.3.2. Zero Air In.....	34
3.3.3. Output Manifold	35
3.3.4. Exhaust.....	35
3.3.5. Measuring An External Ozone Source	35
3.4. Initial Operation	35
3.4.1. Start-Up	35
3.4.2. Warm Up	35
3.4.3. Warning Messages.....	36
3.4.4. Functional Check.....	38
3.4.5. Operating Modes for the O ₃ Generator	39
3.4.5.1. CNST (CONSTANT)	39
3.4.5.2. BNCH (BENCH).....	39
3.4.6. Setting the O ₃ Generator Mode.....	39
3.4.7. Setting the output Flow Rate	40
3.4.7.1. Calculating Output Flow Rate	40
3.4.7.2. Output Flow Setup	40
4. OPERATING THE CALIBRATOR	41
4.1. Test Functions	42
4.2. Overview of Operating modes.....	43
4.3. Standby Mode	44
4.4. General Information about the GENERATE mode.....	45
4.4.1. GENERATE > AUTO: Basic Generation of Calibration Gas.....	45
4.5. Automatic Calibration Sequences	45
4.5.1. SETUP > SEQ: Programming Calibration Sequences.....	46
4.5.1.1. Activating a Sequence from the T703/T703U Front Panel	47
4.5.1.2. Naming a Sequence	48
4.5.1.3. Setting the Repeat Count for a Sequence	49

4.5.1.4. Using the Internal Clock to Trigger Sequences	50
4.5.1.5. Setting Up Control Inputs for a Sequence	53
4.5.1.6. Setting Up Control Outputs for a Sequence	54
4.5.1.7. Setting the Progress Reporting Mode for the Sequences	55
4.5.2. Adding Sequence Steps	56
4.5.2.1. The GENERATE Step	57
4.5.2.2. The STANDBY Step	58
4.5.2.3. The DURATION Step	58
4.5.2.4. The EXECSEQ Step	59
4.5.2.5. The CC OUTPUT Step	60
4.5.2.6. Deleting or Editing an Individual Step in a Sequence	61
4.5.3. Deleting a Sequence	62
4.6. SETUP > CFG	63
4.7. SETUP > CLK	64
4.7.1. Setting the Internal Clock's Time and Day	64
4.7.2. Adjusting the Internal Clock's speed	65
4.8. SETUP > PASS	66
4.9. SETUP > DIAG > TEST CHAN OUTPUT: Using the TEST Channel Analog Output	68
4.9.1. Configuring the TEST Channel Analog Output	68
4.9.1.1. The Analog I/O Configuration Submenu	68
4.9.1.2. Selecting a TEST Channel Function to Output	70
4.9.1.3. TEST Channel Voltage Range Configuration	72
4.9.1.4. Turning the TEST Channel Over-Range Feature ON/OFF	73
4.9.1.5. Adding a Recorder Offset to the TEST Channel	74
4.9.2. TEST Channel Calibration	75
4.9.2.1. Enabling or Disabling the TEST CHANNEL Auto-Cal Feature	76
4.9.2.2. Automatic TEST Channel Calibration	77
4.9.2.3. Manual Calibration of the TEST Channel Configured for Voltage Ranges	79
4.9.3. AIN Calibration	81
4.10. SETUP > MORE > VARS: Internal Variables (VARS)	82
4.11. Operating the Calibrator as an O ₃ Photometer	83
4.11.1. Set up for Operation as an O ₃ Photometer	84
4.12. SETUP > LVL: Setting up and using LEADS (Dasibi) Operating Levels	86
4.12.1. General Information about LEADS LEVELS	86
4.12.2. Dot commands	86
4.12.3. Levels	86
4.12.4. Activating an existing LEVEL	87
4.12.5. Programming New LEVELS	88
4.12.5.1. Creating a Generate LEVEL	89
4.12.5.2. Editing or Deleting a LEVEL	90
4.12.6. Configuring LEVEL Status Blocks	91
5. COMMUNICATIONS	93
5.1. Using the Analyser's Communication Ports	93
5.1.1. RS-232 DTE and DCE Communication	93
5.1.2. Serial COM Port Default Settings and Connector Pin Assignments	94
5.1.3. COM Port Baud Rate	96
5.1.4. COM Port Communication Modes	96
5.1.5. COM Port Testing	99
5.1.6. Machine ID	100
5.1.7. Terminal Operating Modes	101
5.1.7.1. Help Commands in Terminal Mode	101
5.1.7.2. Command Syntax	102
5.1.7.3. Data Types	103
5.1.7.4. Status Reporting	103
5.1.7.5. General Message Format	104
5.1.7.6. COM Port Password Security	104

5.2. Remote Access by Modem.....	105
5.3. Multidrop RS-232 Set Up.....	107
5.4. RS-485 Configuration of COM2.....	109
5.5. Remote Access via the USB Port (Option).....	109
5.6. Remote Access via the Ethernet	111
5.6.1. Configuring the Ethernet Interface using DHCP	112
5.6.1.1. Manually Configuring the Network IP Addresses	114
5.6.2. Changing the Calibrator's Hostname	116
5.7. APICOM Remote Control Program	117
6. CALIBRATION AND VERIFICATION.....	119
6.1. Verifying/Calibrating the O ₃ Photometer	119
6.1.1. Setup for Verifying and Calibrating the O ₃ Photometer.....	119
6.1.1.1. Calibration Manifold Exhaust/Vent Line	121
6.1.2. Verifying O ₃ Photometer Performance	122
6.1.3. Calibrating the O ₃ Photometer.....	122
6.1.3.1. Photometer Zero Calibration.....	123
6.1.3.2. Photometer Span Calibration.....	124
6.1.4. O ₃ Photometer Dark Calibration.....	125
6.1.5. O ₃ Photometer Backpressure Compensation Calibration	126
6.2. Calibrating the O ₃ Generator	126
6.2.1. O ₃ Generator Calibration table	127
6.2.2. Viewing O ₃ Generator Calibration Points	128
6.2.3. Adding or Editing O ₃ Generator Calibration Points	129
6.2.4. Deleting O ₃ Generator Calibration Points.....	130
6.2.5. Turning O ₃ Generator Calibration Points ON / OFF.....	131
6.2.6. Performing an Automatic Calibration of the O ₃ Generator	132
6.3. Calibrating Gas Pressure Sensors	133
6.3.1. Gas Pressure Sensor Calibration Set Up.....	133
6.3.2. Calibrating the Pressure Sensors.....	135
6.4. Gas Flow Calibration	136
6.4.1. Calibrating the Photometer's Sample Gas Flow	138
6.4.2. Calibrating the Output Gas Flow	139
6.4.2.1. Output Gas Flow Set Up	139
6.4.2.2. Performing an Output Gas Flow Calibration	140
7. MAINTENANCE SCHEDULE & PROCEDURES	141
7.1. Maintenance Schedule	141
7.2. Performing Leak Checks	145
7.2.1. Pressure Leak Check	145
7.3. Cleaning or replacing the Absorption Tube	147
7.4. Rebuilding the Dry Air Pump	147
7.5. Photometer UV Source Lamp Adjustment	148
7.6. Photometer UV Source Lamp Replacement	150
7.7. Adjustment or Replacement of Ozone Generator UV Lamp	151
8. GENERAL TROUBLESHOOTING & SERVICE	153
8.1. General Troubleshooting	153
8.1.1. Fault Diagnosis with WARNING Messages	154
8.1.2. Fault Diagnosis With Test Functions.....	157
8.1.3. Using the Diagnostic Signal I/O Function.....	158
8.2. Using the Analog Output Test Channel.....	160
8.3. Using the Internal Electronic Status LEDs	161
8.3.1. CPU Status Indicator.....	161
8.3.2. Relay PCA Status LEDs.....	161
8.3.2.1. I ² C Bus Watchdog Status LEDs.....	161
8.3.2.2. Troubleshooting with Relay Board Status LEDs	162
8.4. Subsystem Checkout.....	163

8.4.1. Verify Subsystem Calibration	163
8.4.2. AC Main Power	163
8.4.3. DC Power Supply	163
8.4.4. I ² C Bus	165
8.4.5. Touchscreen Interface	165
8.4.6. LCD Display Module	165
8.4.7. Relay PCA	165
8.4.8. Photometer O ₃ Generator Pressure /Flow Sensor Assembly	166
8.4.9. Motherboard	168
8.4.9.1. A/D Functions	168
8.4.9.2. Test Channel / Analog Outputs Voltage	169
8.4.9.3. Status Outputs	170
8.4.9.4. Control Inputs	171
8.4.9.5. Control Outputs	171
8.4.10. CPU	172
8.4.11. RS-232 Communications	172
8.4.11.1. General RS-232 Troubleshooting	172
8.4.11.2. Troubleshooting Calibrator/Modem or Terminal Operation	173
8.4.12. Temperature Problems.....	173
8.4.12.1. Box / Chassis Temperature	173
8.4.12.2. Photometer Sample Chamber Temperature.....	173
8.4.12.3. UV Lamp Temperature	174
8.4.12.4. Ozone Generator Temperature.....	174
8.5. Troubleshooting the O ₃ Photometer	174
8.5.1. Dynamic Problems with the O ₃ Photometer	174
8.5.1.1. Noisy or Unstable O ₃ Readings at Zero	175
8.5.1.2. Noisy, Unstable, or Non-Linear Span O ₃ Readings	175
8.5.1.3. Slow Response to Changes in Concentration	175
8.5.1.4. The Analog Output Signal Level Does Not Agree With Front Panel Readings	175
8.5.1.5. Cannot Zero	176
8.5.1.6. Cannot Span	176
8.5.2. Checking Measure / Reference Valve	176
8.6. Trouble Shooting the O ₃ Generator.....	176
8.6.1. Troubleshooting the O ₃ Generator in the T703	177
8.6.2. Troubleshooting the O ₃ Generator in the T703U	177
8.7. Repair Procedures.....	178
8.7.1. Repairing Sample Flow Control Assembly.....	178
8.7.2. Disk-On-Module Replacement Procedure	178
8.8. FAQ's.....	180
8.9. Technical Assistance.....	180
9. PRINCIPLES OF OPERATION.....	181
9.1. Pneumatic Operation.....	181
9.1.1. Gas Flow Control.....	181
9.1.1.1. Photometer Critical Flow Orifice	182
9.1.2. Internal Gas Pressure Sensors	182
9.2. Electronic Operation	183
9.2.1. Overview.....	183
9.2.2. Central Processing Unit (CPU).....	184
9.2.2.1. Disk On Module (DOM).....	185
9.2.2.2. Flash Chip	185
9.2.3. Relay PCA.....	185
9.2.3.1. Valve Control.....	186
9.2.3.2. Heater Control.....	187
9.2.3.3. Relay PCA Status LEDs and Watch Dog Circuitry	187
9.2.3.4. Relay PCA Watchdog Indicator (D1)	188
9.2.4. Motherboard	189

9.2.4.1. A to D Conversion	189
9.2.4.2. Sensor Inputs	189
9.2.4.3. Thermistor Interface	189
9.2.4.4. Analog Outputs	189
9.2.4.5. External Digital I/O	190
9.2.4.6. I ² C Data Bus	190
9.2.4.7. Power-up Circuit.....	190
9.2.5. Power Supply and Circuit Breaker	190
9.2.6. AC Power Configuration	192
9.2.6.1. AC Configuration – Internal Pump (JP7)	193
9.3. Front Panel Touchscreen/Display Interface	194
9.3.1.1. Front Panel Interface PCA	195
9.4. Software Operation.....	195
9.5. O ₃ Generator Operation	196
9.5.1. Principle of Photolytic O ₃ Generation	196
9.5.2. Generator Pneumatic Operation	198
9.5.3. O ₃ Generator Electronic Operation.....	198
9.5.3.1. O ₃ Generator Temperature Control	200
9.6. Photometer Operation	200
9.6.1. Measurement Method	200
9.6.1.1. Calculating O ₃ Concentration.....	200
9.6.1.2. The Measurement / Reference Cycle	202
9.6.1.3. The Absorption Path	204
9.6.1.4. Interferent Rejection.....	205
9.6.2. Photometer Layout	205
9.6.3. Photometer Pneumatic Operation	206
9.6.4. Photometer Electronic Operation	207
9.6.4.1. O ₃ Photometer Temperature Control	207
9.6.4.2. Pneumatic Sensors for the O ₃ Photometer.....	208

LIST OF FIGURES

Figure 3-1:	Front Panel Layout.....	20
Figure 3-2:	Display Screen and Touch Control	21
Figure 3-3:	Display/Touch Control Screen Mapped to Menu Charts.....	22
Figure 3-4:	Rear Panel Layout.....	23
Figure 3-5:	T703 Internal Layout – Top View	24
Figure 3-6:	T703 Pneumatic Diagram.....	25
Figure 3-7:	T703U Internal Layout - Top View	26
Figure 3-8:	T703U Pneumatic Diagram	27
Figure 3-9:	TEST CHANNEL Connector	28
Figure 3-10:	Status Output Connector.....	29
Figure 3-11:	Digital Control Input Connectors	31
Figure 3-12:	Digital Control Output Connector	32
Figure 3-13:	Basic Pneumatic Setup	34
Figure 3-14:	Output Pressure Regulator Assembly.....	40
Figure 4-1:	Front Panel Display	43
Figure 4-2:	TEST CHANNEL Connector	68
Figure 4-3:	Setup for Calibrating the TEST CHANNEL	79
Figure 4-4:	Set up to Measure an External O ₃ Source	84
Figure 4-5:	LEADS Level Display Format.....	90
Figure 5-1:	Default Pin Assignments for Rear Panel COM Port connectors (RS-232 DCE & DTE).....	94
Figure 5-2:	CPU COM1 & COM2 Connector Pin-Outs for RS-232 Mode	95
Figure 5-3:	Jumper and Cables for Multidrop Mode	108
Figure 5-4:	RS232-Multidrop PCA Host/Calibrator Interconnect Diagram	109
Figure 5-5:	APICOM Remote Control Program Interface	117
Figure 6-1:	Set up for Verifying Optional O ₃ Photometer Using Internal O ₃ Generator.....	120
Figure 6-2:	Set up for Verifying Optional O ₃ Photometer Using an External O ₃ Generator	121
Figure 6-3:	Pressure Calibration Monitor Point – T703	133
Figure 6-4:	Pressure Calibration Monitor Points – T703U.....	134
Figure 6-5:	Pressure Regulator Monitor Connection Point (T703 and T703U)	134
Figure 6-6:	O ₃ Regulator Pressure Monitor Point (T703U only)	135
Figure 6-7:	Output Flow Calibration Monitor Point – T703	139
Figure 7-1:	T703 Pneumatic setup for performing Pressure Leak Checks	146
Figure 7-2:	T703U Pneumatic Setup for Performing Pressure Leak Checks.....	146
Figure 7-3:	Photometer – Location of UV Detector Gain Adjustment & UV Lamp Set Screw.....	150
Figure 7-4:	O ₃ Generator Temperature Thermistor and DC Heater Locations	151
Figure 8-1:	Example of Signal I/O Function.....	159
Figure 8-2:	CPU Status Indicator.....	161
Figure 8-3:	Relay PCA Status LEDs Used for Troubleshooting	162
Figure 8-4:	Location of DC Power Test Points on Relay PCA	164
Figure 8-5:	Critical Flow Restrictor Assembly Disassembly	178
Figure 9-3:	Electronic Block Diagram	183
Figure 9-4:	CPU Board Annotated.....	184
Figure 9-5:	Relay Board PCA with AC Relay Retainer Removed	186
Figure 9-6:	Heater Control Loop Block Diagram.	187
Figure 9-7:	Status LED Locations – Relay PCA	187
Figure 9-8:	Power Distribution Block diagram	192
Figure 9-9:	Location of the AC Configuration Jumper for the Dry Air Pump	193
Figure 9-10:	Pump AC Power Jumpers (JP7)	194
Figure 9-11:	Front Panel Layout.....	195
Figure 9-12:	Schematic of Basic Software Operation.....	196
Figure 9-13:	O ₃ Generator Internal Pneumatics	197
Figure 9-14:	O ₃ Generator Valve and Gas Fixture Locations	198
Figure 9-15:	O ₃ Generator Electronic Block Diagram.....	199
Figure 9-16:	O ₃ Generator Electronic Components Location	199

Figure 9-17:	O ₃ Generator Temperature Thermistor and DC Heater Locations	200
Figure 9-18:	T703 O ₃ Photometer Gas Flow – Measure Cycle	203
Figure 9-19:	T703 O ₃ Photometer Gas Flow – Reference Cycle	203
Figure 9-20:	T703U O ₃ Photometer Gas Flow – Measure Cycle	204
Figure 9-21:	T703U O ₃ Photometer Gas Flow – Reference Cycle	204
Figure 9-22:	O ₃ Photometer Absorption Path	205
Figure 9-23:	O ₃ Photometer Layout – Top Cover Removed	206
Figure 9-24:	O ₃ Photometer Electronic Block Diagram	207

LIST OF TABLES

Table 2-1:	T703/T703U System Specifications	17
Table 2-2:	T703/T703U Specifications for Ozone Generator	17
Table 2-3:	T703/T703U Specifications for O ₃ Photometer	18
Table 3-1:	Display Screen and Touch Control Description	21
Table 3-2:	Rear Panel Description	23
Table 3-3:	Status Output Pin Assignments	29
Table 3-4:	Control Input Pin Assignments	30
Table 3-5:	Control Output Pin Assignments	32
Table 3-6:	Possible Warning Messages at Start-Up	37
Table 4-1:	Test Functions Defined	42
Table 4-2:	Calibrator Operating Modes	43
Table 4-3:	Automatic Calibration SEQUENCE Set Up Attributes	46
Table 4-4:	Calibration SEQUENCE Step Instruction	46
Table 4-5:	Sequence Progress Reporting Mode	55
Table 4-6:	Password Levels	66
Table 4-7:	DIAG - Analog I/O Functions	68
Table 4-8:	Test Channels Functions Available on the Analog Output	70
Table 4-9:	Analog Output Voltage Range Min/Max	72
Table 4-10:	Voltage Tolerances for the TEST CHANNEL Calibration	79
Table 4-11:	Variable Names (VARS)	82
Table 5-1:	COM Port Communication Modes	97
Table 5-2:	Terminal Mode Software Commands	101
Table 5-3:	Teledyne API Serial I/O Command Types	102
Table 5-4:	Ethernet Status Indicators	111
Table 5-5:	LAN/Internet Configuration Properties	112
Table 6-1:	T703/T703U Pressure Sensors	133
Table 6-2:	T703/T703U Gas Pressure to Output Flow conversion Table	137
Table 7-1:	T703 Maintenance Schedule	143
Table 8-1:	Front Panel Warning Messages	156
Table 8-2:	Test Functions - Indicated Failures	157
Table 8-3:	Test Channel Outputs as Diagnostic Tools	160
Table 8-4:	Relay PCA Watchdog LED Failure Indications	161
Table 8-5:	Relay PCA Status LED Failure Indications	162
Table 8-6:	DC Power Test Point and Wiring Color Codes	164
Table 8-7:	DC Power Supply Acceptable Levels	164
Table 8-8:	Relay PCA Control Devices	166
Table 8-9:	Analog Output Test Function - Nominal Values Voltage Outputs	170
Table 8-10:	Status Outputs Check	170
Table 8-11:	T703 Control Input Pin Assignments and Corresponding Signal I/O Functions	171
Table 8-12:	Control Outputs Pin Assignments and Corresponding Signal I/O Functions Check	171
Table 9-1:	Relay Board Status LEDs	188
Table 9-2:	AC Power Configuration for Internal Pumps (JP7)	193
Table 9-3:	Photometer Measurement / Reference Cycle	202

LIST OF APPENDICES

APPENDIX A - SOFTWARE DOCUMENTATION

APPENDIX B - SPARE PARTS LIST

APPENDIX C - WARRANTY REPAIR QUESTIONNAIRE

APPENDIX D - ELECTRONIC SCHEMATICS

1. INTRODUCTION

This manual provides information and operation instructions for the Model T703 and the Model T703U calibrators. For simplicity the information and instructions in this manual refer to both models except where the Model T703U diverges in technical or operational aspects, in which case the T703U is clearly defined.

1.1. T703/T703U CALIBRATOR OVERVIEW

The Model T703 and the T703U are microprocessor controlled ozone calibrators for calibration of precision ambient ozone instruments, such as the TAPI T400. They feature an internal ozone photometer that provides very accurate closed loop feedback control of the ozone concentration. However, the T703U is capable of generating ozone in a low range (fractional mode), for ultra-low ozone production.

As many as 50 independent calibration sequences may be programmed into the T703/T703U, covering time periods of up to one year. The setup of sequences is simple and intuitive. These sequences may be actuated manually, automatically, or by a remote signal. The sequences may be uploaded remotely, including remote editing. All programs are maintained in non-volatile memory.

The T703/T703U design emphasizes fast response, repeatability, overall accuracy and ease of operation. It may be combined with the Model 701 Zero Air Generator to provide the ultimate in easy to use, precise calibration for your ozone instruments.

Some of the exceptional features of your T703/T703U Photometric O₃ Calibrator are:

- Advanced T-Series electronics
- LCD Graphical User Interface with capacitive touch screen
- Bi directional RS-232 and 10/100Base-T Ethernet, optional USB and RS-485, ports for remote operation
- Front panel USB ports for peripheral devices
- 12 independent timers for sequences
- Nested sequences (up to 5 levels)
- Internal ozone generator and photometer allows use as primary or transfer standard
- UV Lamp Feedback modes: current control; photometer control
- Lightweight for transportability
- T703U: ultra-low ozone production down to 3ppb

1.2. OPTIONS

Option	Option Number	Description/Notes														
Rack Mounting		For mounting the analyzer in standard 19" racks														
	20A	Rack mount brackets with 26 in. (660 mm) chassis slides														
	20B	Rack mount brackets with 24 in. (610 mm) chassis slides														
	21	Rack mount brackets only														
		 <ul style="list-style-type: none"> • The T703/T703U WEIGHS about 16.3 kg (36 pounds). To avoid personal injury we recommend two persons lift and carry the calibrator. • Disconnect all cables and tubing from the calibrator before carrying it. 														
Carrying Handle		Strap to carry unit														
	29	Carrying handle (strap)														
Parts Kits		Spare parts and expendables for 1-year operation														
	42A	Kit, Spares for One Unit														
Communications		For remote serial, network and Internet communication with the analyzer.														
		<table border="1"> <thead> <tr> <th>Type</th> <th>Description</th> </tr> </thead> <tbody> <tr> <td>60A</td> <td>RS-232</td> <td>Shielded, straight-through DB-9F to DB-25M cable, about 1.8 m long. Used to interface with older computers or code activated switches with DB-25 serial connectors.</td> </tr> <tr> <td>60B</td> <td>RS-232</td> <td>Shielded, straight-through DB-9F to DB-9F cable of about 1.8 m length.</td> </tr> <tr> <td>60C</td> <td>Ethernet</td> <td>Patch cable, 2 meters long, used for Internet and LAN communications.</td> </tr> <tr> <td>60D</td> <td>USB</td> <td>Cable for direct connection between instrument (rear panel USB port) and personal computer.</td> </tr> </tbody> </table>	Type	Description	60A	RS-232	Shielded, straight-through DB-9F to DB-25M cable, about 1.8 m long. Used to interface with older computers or code activated switches with DB-25 serial connectors.	60B	RS-232	Shielded, straight-through DB-9F to DB-9F cable of about 1.8 m length.	60C	Ethernet	Patch cable, 2 meters long, used for Internet and LAN communications.	60D	USB	Cable for direct connection between instrument (rear panel USB port) and personal computer.
Type	Description															
60A	RS-232	Shielded, straight-through DB-9F to DB-25M cable, about 1.8 m long. Used to interface with older computers or code activated switches with DB-25 serial connectors.														
60B	RS-232	Shielded, straight-through DB-9F to DB-9F cable of about 1.8 m length.														
60C	Ethernet	Patch cable, 2 meters long, used for Internet and LAN communications.														
60D	USB	Cable for direct connection between instrument (rear panel USB port) and personal computer.														
Cables																
USB Port	64A	For rear panel connection to personal computer.														
RS-232 Multidrop	62	Multidrop/LVDS card seated on the analyzer's CPU card. Each instrument in the multidrop network requires this card and a communications cable (Option 60B).														
External Valve Driver Capability - For driving up to eight, 8-watt valves																
	48A	12V External Valve Driver Capability														
	48B	24V External Valve Driver Capability														
NIST Traceable, Primary Standard Certification for use as a Primary Ozone Standard if purchased with the O₃ generator and photometer options, 1A and 2A, respectively.																
	95C	Calibration to NIST-SRP														
	95D	Calibration as a Transfer Standard (6x6)														
<p>The Model T703 can be used as a Primary Ozone Standard. For this application the performance of the T703 Photometric Calibrator is calibrated to Standard Reference Photometer (SRP) Calibrators ordered with this option are verified and validated in accordance with the procedures prescribed by the U.S. Environmental Protection Agency (EPA) under Title 40 of the Code of Federal Regulations, Part 50, Appendix D (40 CFR Part 50).</p>																
Special Features		Built in features, software activated														
	N/A	Maintenance Mode Switch , located inside the instrument, places the analyzer in maintenance mode where it can continue sampling, yet ignore calibration, diagnostic, and reset instrument commands. This feature is of particular use for instruments connected to Multidrop or Hessen protocol networks. Call Technical Support for activation.														
	N/A	Second Language Switch activates an alternate set of display messages in a language other than the instrument's default language. Call Technical Support for a specially programmed Disk on Module containing the second language.														

2. SPECIFICATIONS AND APPROVALS

2.1. SPECIFICATIONS

Table 2-1: T703/T703U System Specifications

PARAMETER	SPECIFICATION	
Linearity	± 1.0% of full scale	
Precision	1.0 ppb	
Response Time	T703	T703U
	<180 seconds to 95%	240 seconds to 95%
Stability (7-days)	<1% photometer feedback; <3% without photometer feedback (CNST or REF)	
Operating Temperature Range	5-40°C	
Humidity Range	0 - 95% RH, non-condensing	
Environmental Conditions	Installation Category (Over Voltage Category) II Pollution Degree 2 Intended for Indoor Use Only at Altitudes ≤ 2000m	
Dimensions (H x W x D)	7" (178 mm) x 17" (432 mm) x 24" (609 mm)	
Weight	35.5 lbs (16.1 kg) including internal zero air pump	
AC Power	Rating	Typical Power Consumption
	100V – 120V, 60Hz, 3.0 A 220V – 240V, 50/60Hz, 3.0 A	75 W (with Zero Air Pump 150 W) 95 W (with Zero Air Pump 170 W)
Analog Output Ranges	0.1 V, 1 V, 5 V or 10 V (selectable) Range with 5% under/over-range	
Standard I/O	1 Ethernet: 10/100Base-T 2 RS-232 (300 – 115,200 baud) 2 USB device ports 8 opto-isolated digital control outputs 12 opto-isolated digital control inputs 8 opto-isolated digital status outputs	
Optional I/O	1 USB com port 1 RS485 Multidrop RS232	

Table 2-2: T703/T703U Specifications for Ozone Generator

	T703	T703U
Flow Rate	1 to 5 LPM adjustable	w/internal zero air source: 1 to 5 LPM adjustable w/external zero air source: 1 to 15 LPM adjustable
Concentration	Min: 50 ppb at 2 LPM Max: 5 ppm at 1 LPM	Min: 3 ppb at 5 LPM Max: 5 ppm at 1 LPM
Output	Min: 100 ppb LPM Max: 5 ppm LPM	Min: 15 ppb LPM Max: 5 ppm LPM
Response Time:	<180 sec. to 98%	<240 sec. to 98%
Optical Feedback	Standard	

Table 2-3: T703/T703U Specifications for O₃ Photometer

Ranges	0-100 ppb to 0-10 ppm, user selectable
Zero Noise	0.3ppb (RMS)
Span Noise	<0.5%
Lower Detectable Limits	0.6 ppb (RMS)
Precision	1.0 ppb
Linearity	1.0% of Full Scale
Lag Time	<10 seconds
Rise/Fall Time	<20 sec (photometer response)
Zero Drift	<1.0 ppb / 7 days
Span Drift	<1% / 24 hours; <2% / 7 days
Flow Rate	800 cc ³ /min +/- 10%

2.2. APPROVALS AND CERTIFICATIONS

The Teledyne API Models T703 and T703U Photometric O₃ Calibrators were tested and certified for Safety and Electromagnetic Compatibility (EMC). This section presents the compliance statements for those requirements and directives.

2.2.1. SAFETY

IEC 61010-1:2001, Safety requirements for electrical equipment for measurement, control, and laboratory use.

CE: 2006/95/EC, Low-Voltage Directive

2.2.2. EMC

EN 61326-1 (IEC 61326-1), Class A Emissions/Industrial Immunity

EN 55011 (CISPR 11), Group 1, Class A Emissions

FCC 47 CFR Part 15B, Class A Emissions

CE: 2004/108/EC, Electromagnetic Compatibility Directive

2.2.3. OTHER TYPE CERTIFICATIONS

For additional certifications, please contact Technical Support:

Toll-free Phone: 800-324-5190

Phone: 858-657-9800

Fax: 858-657-9816

Email: sda_techsupport@teledyne.com

3. GETTING STARTED

3.1. UNPACKING AND INITIAL SETUP



CAUTION

THE T703 WEIGHS ABOUT 16.1 KG (35.5 POUNDS) WITHOUT OPTIONS INSTALLED. TO AVOID PERSONAL INJURY, WE RECOMMEND USING TWO PERSONS TO LIFT AND CARRY THE CALIBRATOR.



CAUTION – Avoid Warranty Invalidation

Printed circuit assemblies (PCAs) are sensitive to electro-static discharges too small to be felt by the human nervous system. Damage resulting from failure to use ESD protection when working with electronic assemblies will void the instrument warranty.

For more information on preventing ESD damage see *A Primer on Electro-Static Discharge*; the manual can be downloaded from our website at <http://www.teledyne-api.com> under Help Center > Product Manuals in the Special Manuals section.



CAUTION – Avoid Damage to the Instrument

Do not operate the instrument without first removing dust plugs from pneumatic ports.

NOTE

It is recommended that you store shipping containers/materials for future use if/when the instrument should be returned to the factory for repair and/or calibration service. See Warranty section in this manual and shipping procedures on our Website at <http://www.teledyne-api.com> under Customer Support > Return Authorization.



WARNING!

NEVER DISCONNECT ELECTRONIC CIRCUIT BOARDS, WIRING HARNESSSES OR ELECTRONIC SUBASSEMBLIES WHILE THE UNIT IS UNDER POWER.

1. Inspect the received packages for external shipping damage. If damaged, please advise the shipper first, then Teledyne API.
2. Included with your calibrator is a printed record of the final performance characterization performed on your instrument at the factory. This record, titled *Final Test and Validation Data Sheet* (P/N 05760) is an important quality assurance and calibration record for this instrument. It should be placed in the quality records file for this instrument.
3. Carefully remove the top cover of the calibrator and check for internal shipping damage.
 - Remove the set-screw located in the top, center of the front panel.

- Remove the 2 screws fastening the top cover to the unit (one per side towards the rear).
 - Slide the cover backwards until it clears the calibrator's front bezel.
 - Lift the cover straight up.
4. Inspect the interior of the instrument to make sure all circuit boards and other components are in good shape and properly seated.
 5. Check the connectors of the various internal wiring harnesses and pneumatic hoses to make sure they are firmly and properly seated.
 6. Verify that all of the optional hardware ordered with the unit has been installed. These are checked on the paperwork accompanying the calibrator.

VENTILATION CLEARANCE: Whether the calibrator is set up on a bench or installed into an instrument rack, be sure to leave sufficient ventilation clearance.

AREA	MINIMUM REQUIRED CLEARANCE
Back of the instrument	10 cm / 4 inches
Sides of the instrument	2.5 cm / 1 inch
Above and below the instrument.	2.5 cm / 1 inch

3.1.1. FRONT, REAR, AND INTERNAL CALIBRATOR DESCRIPTION

Figure 3-1 shows the location of the front panel components. Figure 3-2 shows the display screen, which is described in Table 3-1.

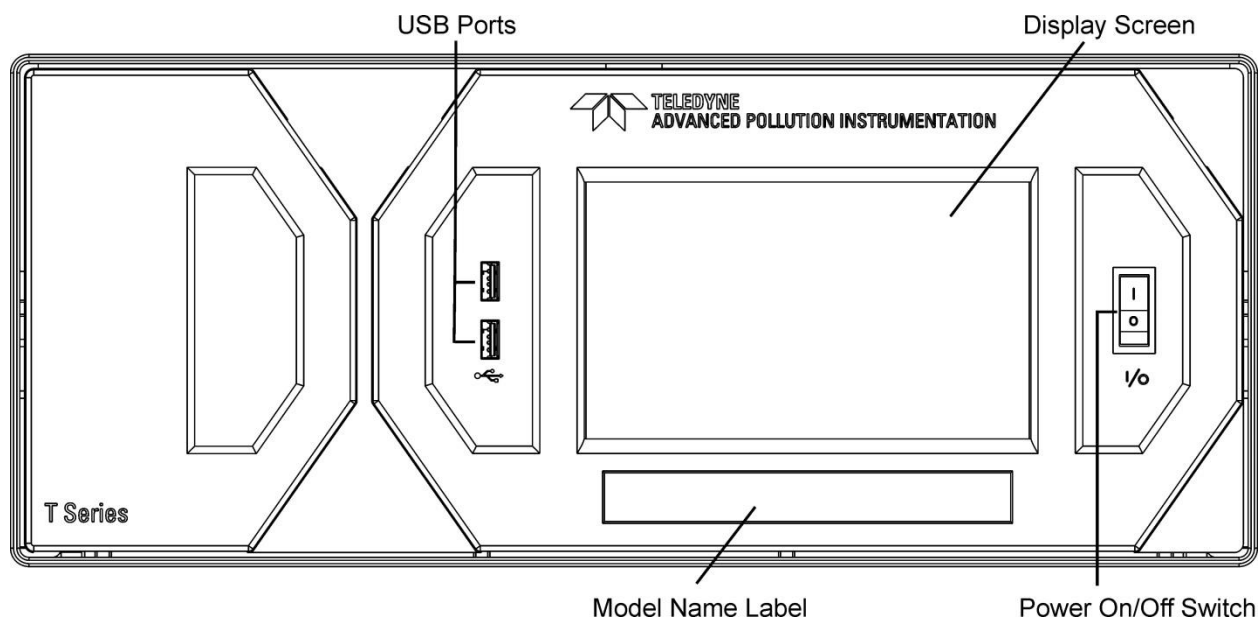

Figure 3-1: Front Panel Layout



Figure 3-2: Display Screen and Touch Control

The front panel liquid crystal display (LCD) screen includes touch control. Upon calibrator start-up, the LCD shows a splash screen and other initialization indicators before the main display appears.



CAUTION – Avoid Damaging Touchscreen
Do not use hard-surfaced instruments such as pens to operate the touch screen buttons.

Table 3-1: Display Screen and Touch Control Description

Field	Description/Function			
LEDs indicating the states of the calibrator:				
	Name	Color	State	Definition
	Active	Green	off	Unit is operating in STANDBY mode. This LED is lit when the instrument is actively producing calibration gas (GENERATE mode).
	Auto Timer	Yellow	off	This LED is lit only when the calibrator is performing an automatic calibration sequence.
	Fault	Red	blinking	The calibrator is warming up and therefore many of its subsystems are not yet operating within their optimum ranges. Various warning messages may appear in the Param field.
Target/ Actual	Gas concentrations, Cal gas MFC and Diluent MFC values with unit of measure			
Mode	Displays the name of the calibrator's current operating mode (default is STANDBY at initial startup).			
Param	Displays a variety of informational messages such as warning messages, operational data, test function values and response messages during interactive tasks.			
Touchscreen control: row of eight buttons with dynamic, context sensitive labels; buttons are blank when inactive/inapplicable.				

Figure 3-3 shows how the front panel display is mapped to the menu charts that are illustrated throughout this manual. The Mode, Param (parameters), and Target/Actual (gas concentration) fields in the display screen are represented across the top row of each menu chart. The eight touch control buttons along the bottom of the display screen are represented in the bottom row of each menu chart.

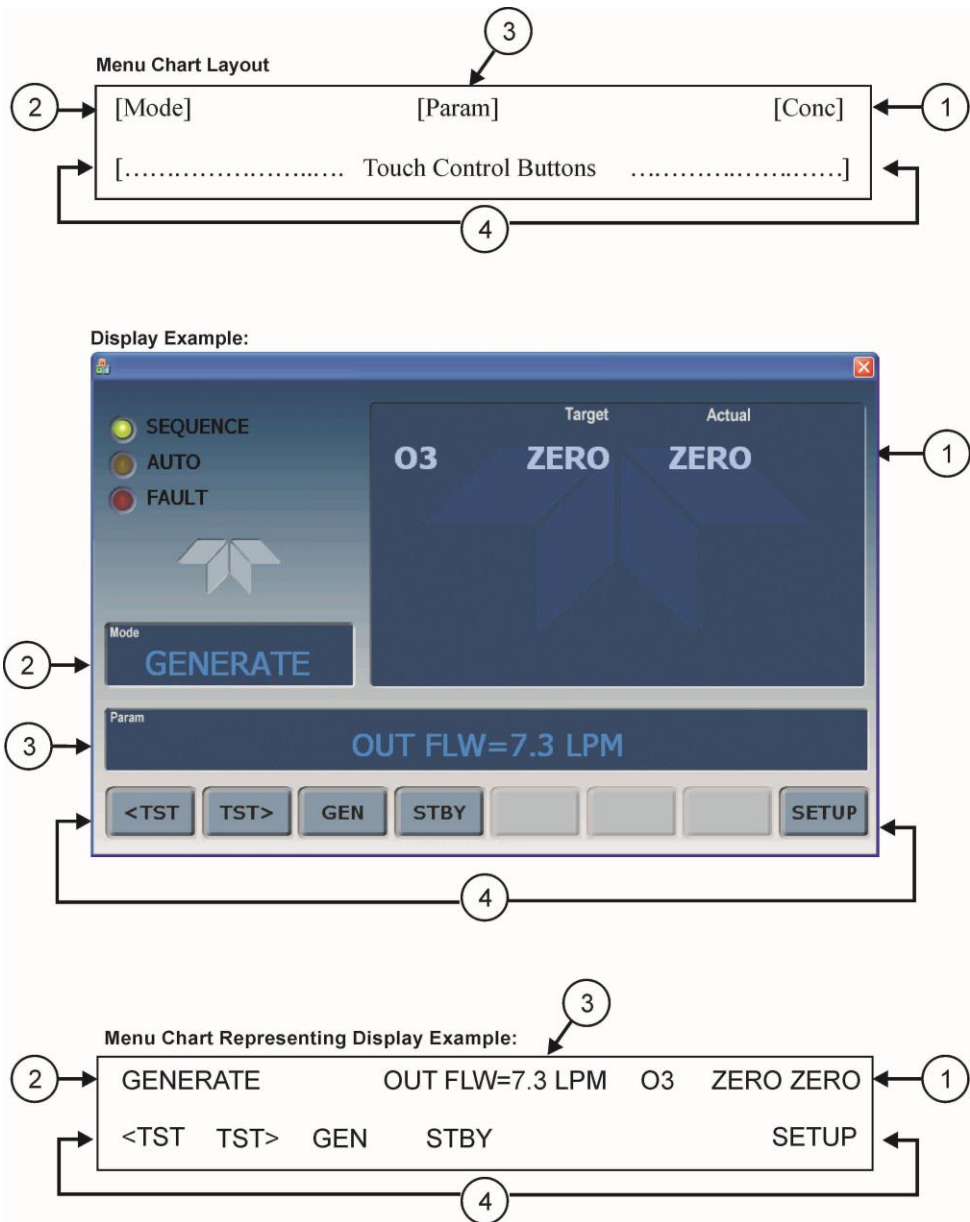

Figure 3-3: Display/Touch Control Screen Mapped to Menu Charts

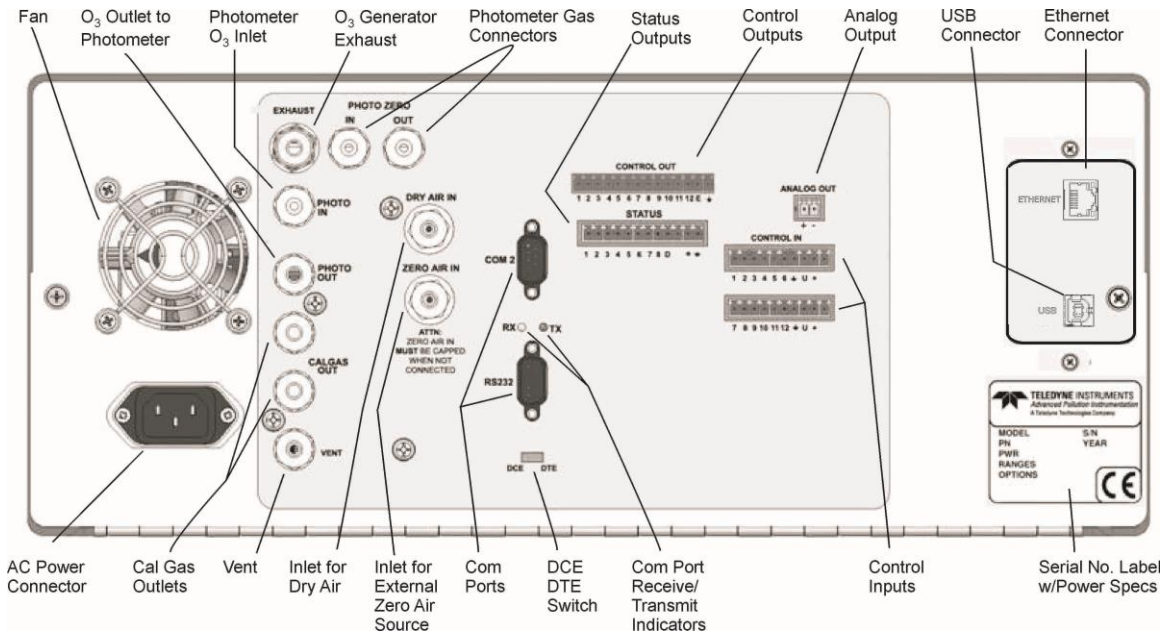



Figure 3-4: Rear Panel Layout

Table 3-2. Rear Panel Description

Component	Function
Fan	For cooling: pulls ambient air through chassis from side vents; exhausts through rear.
 AC Power Connector	Connector for three-prong cord to apply AC power to the instrument CAUTION! The cord's power specifications (specs) MUST comply with the power specs on the calibrator's rear panel Model number label.
 EXHAUST	Exhaust gas from ozone generator and photometer (option) CAUTION! Exhaust gas must be vented outside.
PHOTO ZERO IN	Inlet for photometer Zero Gas (option)
PHOTO ZERO OUT	Outlet for photometer Zero Gas (option)
PHOTO IN	Measurement gas input for O ₃ photometer (option)
PHOTO OUT	Calibration gas outlet to O ₃ photometer (option)
CAL GAS OUT	Two outlets for calibration gas.
VENT	Vent port for output manifold
DRY AIR IN	Inlet for dry air.
ZERO AIR IN	Inlet for external zero air source – MUST BE CAPPED WHEN NOT CONNECTED.
COM 2	Serial communications port for RS-232 or RS-485 (option).
RX TX	LEDs indicate receive (RX) and transmit (TX) activity on the when blinking.
RS-232	Serial communications port for RS-232 only.
DCE DTE	Switch to select either data terminal equipment or data communication equipment during RS-232 communication. (Section 5.1.1)
CONTROL OUT	For outputs to devices such as Programmable Logic Controllers (PLCs).
STATUS	For outputs to devices such as Programmable Logic Controllers (PLCs).
ANALOG OUT	For voltage or current loop outputs to a strip chart recorder and/or a data logger.
CONTROL IN	For remotely activating the zero and span calibration modes.
ETHERNET	Connector for network or Internet remote communication, using Ethernet cable.
USB	Connector for direct connection (option) to a personal computer, using USB cable.
Label w/power specs	Identifies the instrument model number and lists voltage and frequency specifications

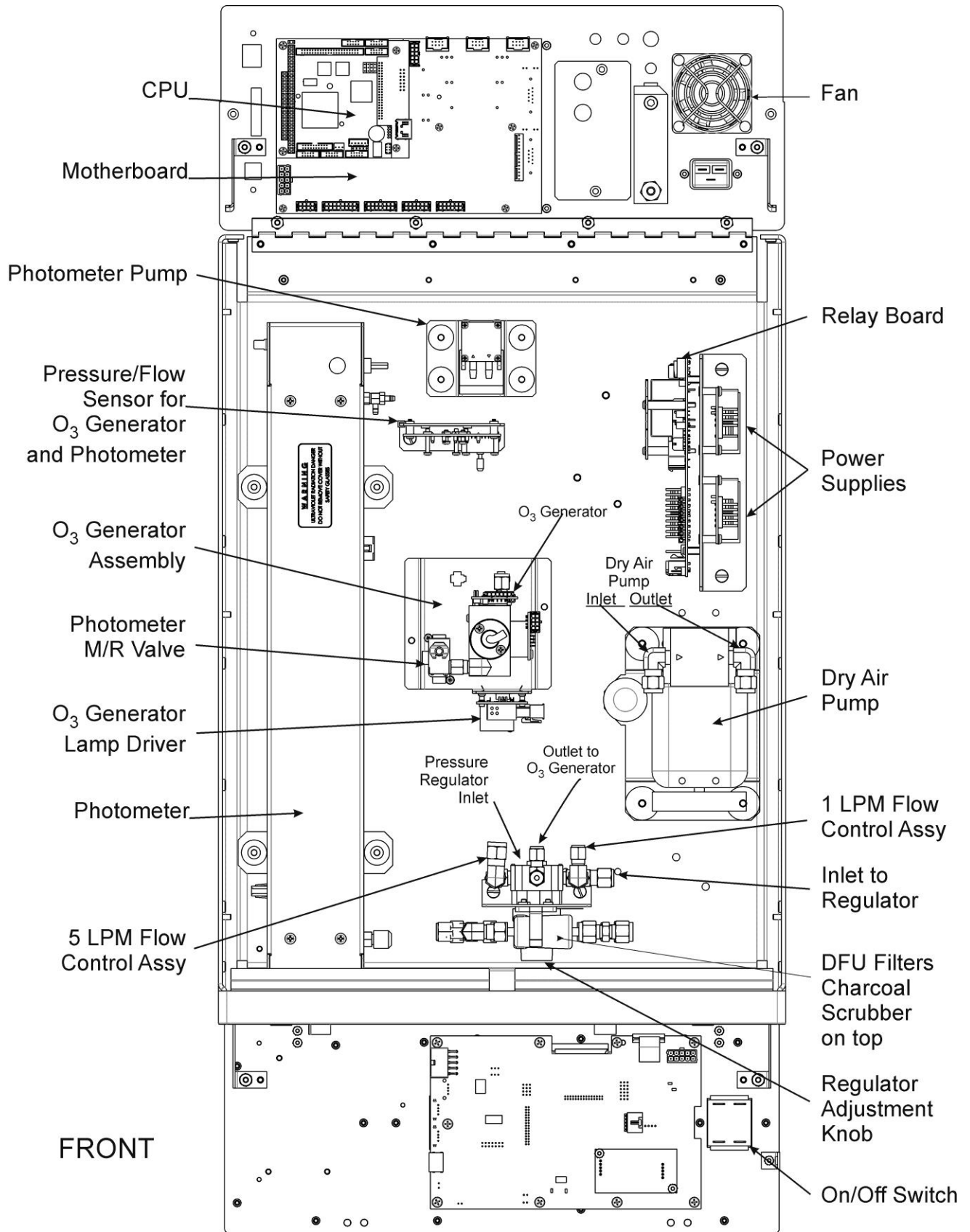

Figure 3-5: T703 Internal Layout – Top View

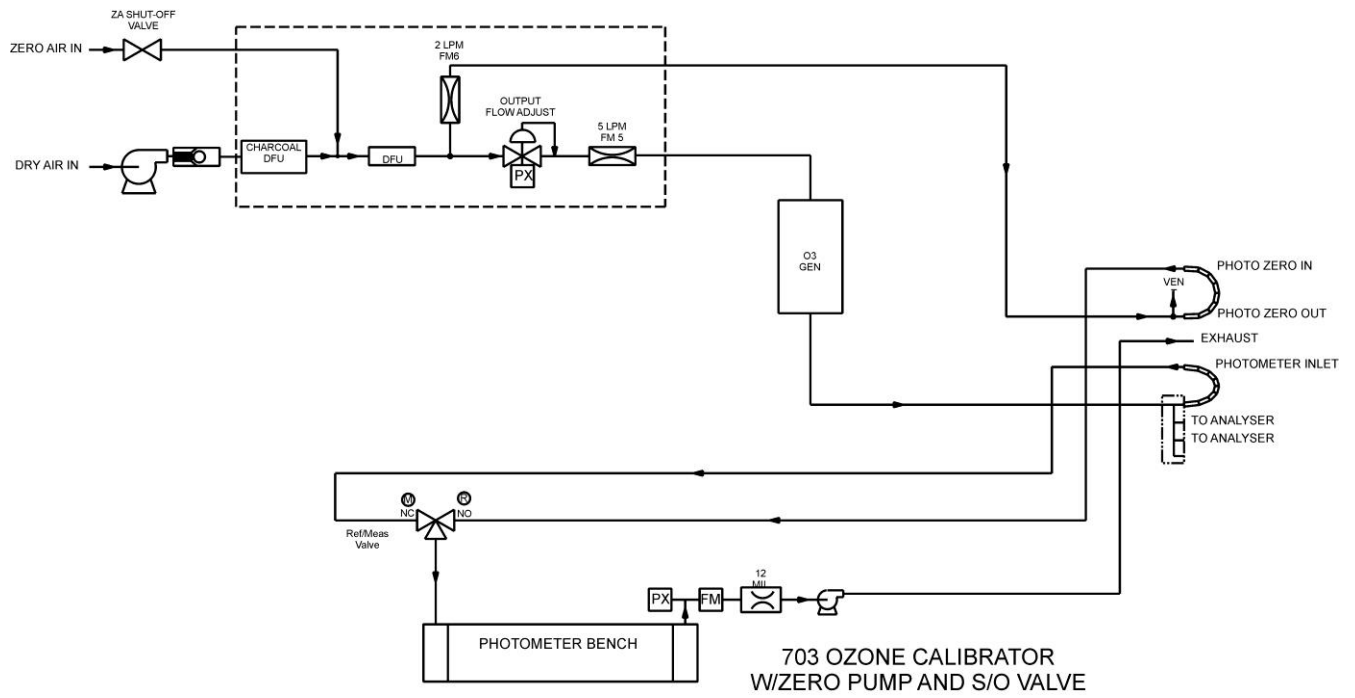

Figure 3-6: T703 Pneumatic Diagram

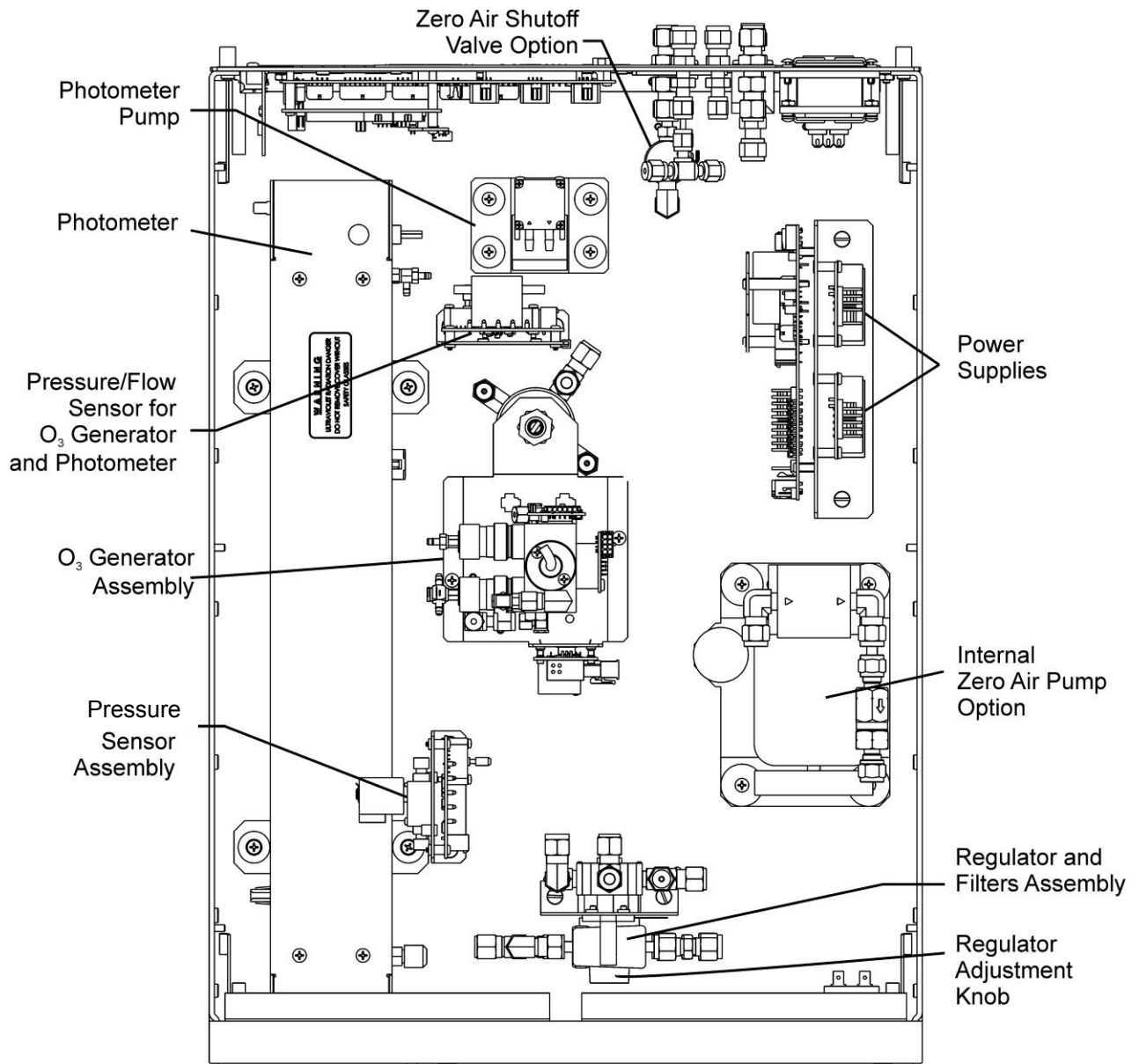

Figure 3-7: T703U Internal Layout - Top View

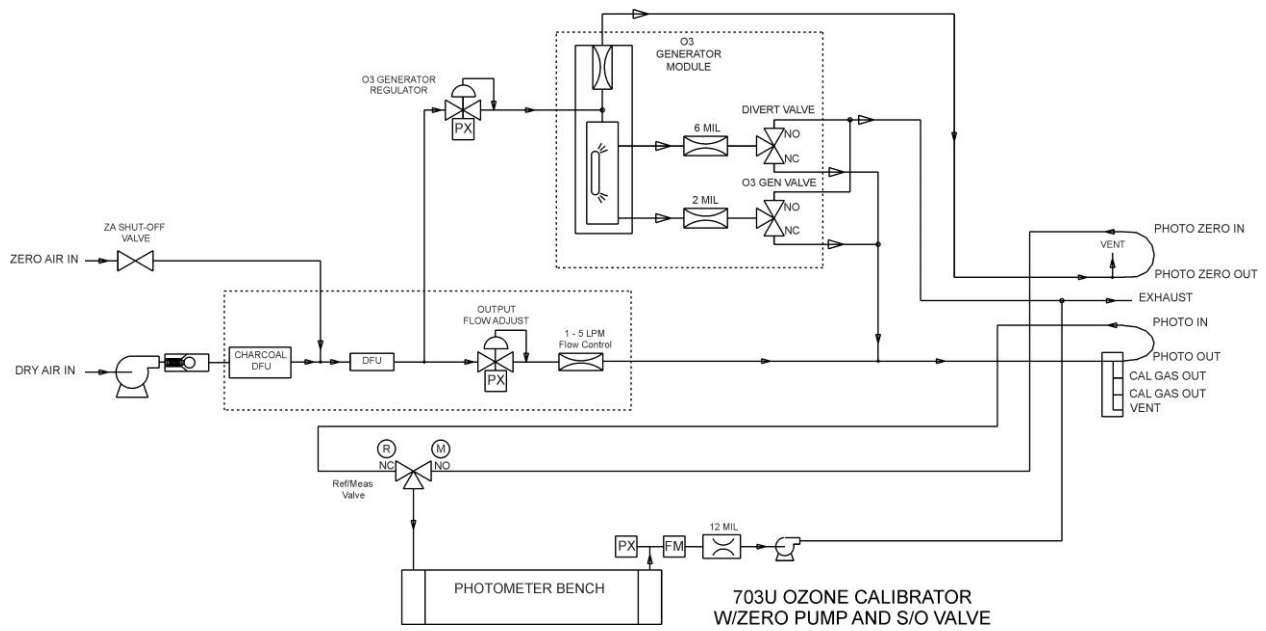

Figure 3-8: T703U Pneumatic Diagram

3.2. ELECTRICAL CONNECTIONS

NOTE

To maintain compliance with EMC standards, it is required that the cable length be no greater than 3 meters for all I/O connections, which include, Analog Out, Control Out, Status, Control In, Ethernet/LAN, USB, RS-232, and RS-485.

3.2.1. POWER CONNECTION

Verify the correct line voltage and frequency configuration on the serial number tag on the rear panel of the T703.

Attach the power cord to the calibrator and plug it into a power outlet capable of carrying at least 10 A current at your AC voltage and that it is equipped with a functioning earth ground.



WARNING

**HIGH VOLTAGES ARE PRESENT INSIDE THE CALIBRATOR'S CHASSIS.
POWER CONNECTION MUST HAVE FUNCTIONING GROUND CONNECTION.
DO NOT DEFEAT THE GROUND WIRE ON POWER PLUG.
TURN OFF CALIBRATOR POWER BEFORE DISCONNECTING OR
CONNECTING ELECTRICAL SUBASSEMBLIES.**



CAUTION – AVOID PERSONAL INJURY

**DO NOT LOOK AT THE PHOTOMETER UV LAMP.
UV LIGHT CAN CAUSE EYE DAMAGE.
ALWAYS WEAR GLASSES MADE FROM SAFETY UV FILTERING GLASS
(PLASTIC GLASSES ARE INADEQUATE).**

3.2.2. ANALOG OUTPUT TEST CHANNEL CONNECTIONS

The T703 is equipped with an analog output channel accessible through a connector on the back panel of the instrument. The standard configuration for this output is 0-5 VDC. It can be set by the user to output one of a variety of diagnostic test functions (see Section 4.9.)

To access these signals attach a strip chart recorder and/or data-logger to the appropriate analog output connections on the rear panel of the calibrator.

Pin-outs for the analog output connector at the rear panel of the instrument are:

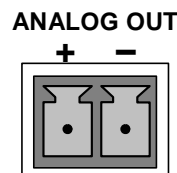

Figure 3-9: TEST CHANNEL Connector

3.2.3. CONNECTING THE STATUS OUTPUTS

The status outputs report calibrator conditions via optically isolated NPN transistors, which sink up to 50 mA of DC current. These outputs can be used interface with devices that accept logic-level digital inputs, such as programmable logic controllers (PLCs). Each Status bit is an open collector output that can withstand up to 40 VDC. All of the emitters of these transistors are tied together and available at D.

NOTE

Most PLCs have internal provisions for limiting the current that the input will draw from an external device. When connecting to a unit that does not have this feature, an external dropping resistor must be used to limit the current through the transistor output to less than 50 mA. At 50 mA, the transistor will drop approximately 1.2V from its collector to emitter.

The status outputs are accessed via a 12-pin connector on the calibrator's rear panel labeled STATUS. The function of each pin is defined in Table 3-3.

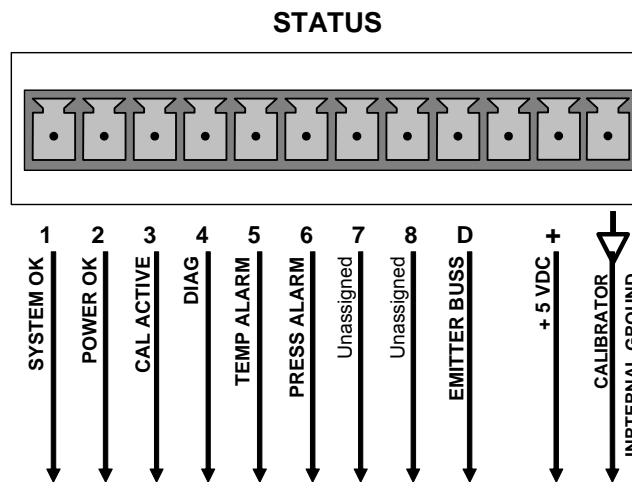

Figure 3-10: Status Output Connector

The pin assignments for the Status Outputs are:

Table 3-3: Status Output Pin Assignments

OUTPUT #	STATUS DEFINITION	CONDITION
1	SYSTEM OK	On, if no faults are present.
2	Unassigned	
3	CAL ACTIVE	On if the calibrator is in GENERATE mode
4	DIAG	On if the calibrator is in DIAGNOSTIC mode
5	TEMP ALARM	On whenever a temperature alarm is active.
6	PRESS ALARM	On whenever gas pressure alarm is active
7 & 8	Unassigned	
D	Emitter BUSS	The emitters of the transistors on pins 1 to 8 are bussed together.
+	DC POWER	+ 5 VDC
↓	Digital Ground	The ground level from the calibrator's internal DC power supplies.

3.2.4. CONNECTING THE CONTROL INPUTS

The calibrator is equipped with 12 digital control inputs that can be used to Initiate various user programmable calibration sequences (see Section 4.5.1.5 for instructions on assigning the control inputs to specific calibration sequences).

Access to these inputs is via 2 separate 10-pin connectors, labeled CONTROL IN, that are located on the calibrator's rear panel.

Table 3-4: Control Input Pin Assignments

CONNECTOR	INPUT	DESCRIPTION
Top	1 to 6	Can be used as either 6 separate on/off switches or as bits 1 through 6 of a 12 bit wide binary activation code (see Section 4.5.1.5)
Bottom	7 to 12	Can be used as either 6 separate on/off switches or as bits 7 through 12 of a 12 bit wide binary activation code (see Section 4.5.1.5)
BOTH	↓	Chassis ground.
Top	U	Input pin for +5 VDC required to activate pins A – F. This can be from an external source or from the “+” pin of the instruments STATUS connector.
Bottom	U	Input pin for +5 VDC required to activate pins G – L. This can be from an external source or from the “+” pin of the instruments STATUS connector.
BOTH	+	Internal source of +5V that can be used to actuate control inputs when connected to the U pin.

There are two methods for energizing the control inputs. The internal +5V available from the pin labeled “+” is the most convenient method. However, if full isolation is required, an external 5 VDC power supply should be used.

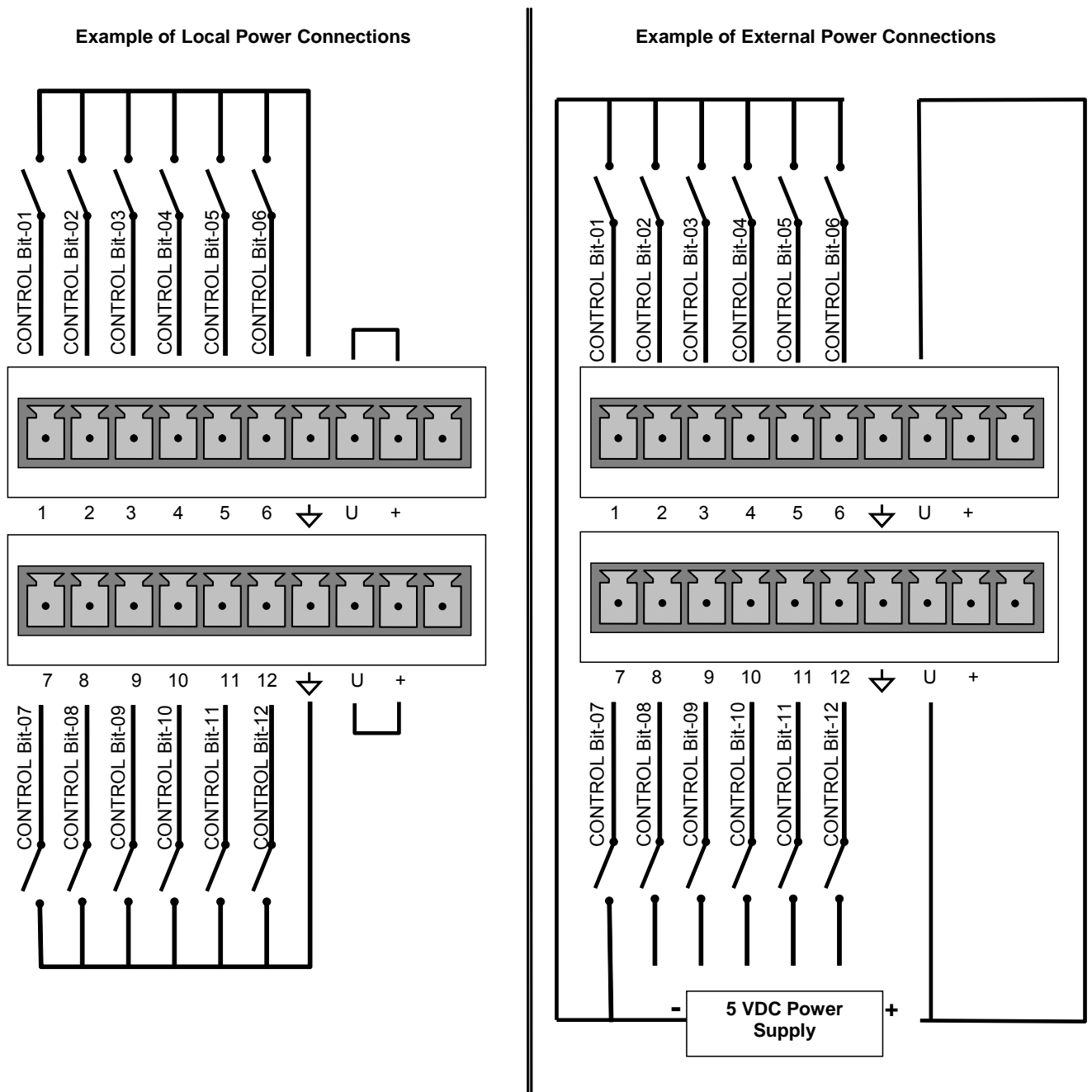

Figure 3-11: Digital Control Input Connectors

3.2.5. CONNECTING THE CONTROL OUTPUTS

The calibrator is equipped with 12 opto-isolated, digital control outputs. These outputs are activated by the user-programmable, calibration sequences (see Section 4.5.1.6 for instructions on assigning the control outputs to specific calibration sequences)

These outputs may be used to interface with devices that accept logic-level digital inputs, such as programmable logic controllers (PLCs), dataloggers, or digital relays/valve drivers.

They are accessed via a 14-pin connector on the calibrator's rear panel (see Figure 3-4).

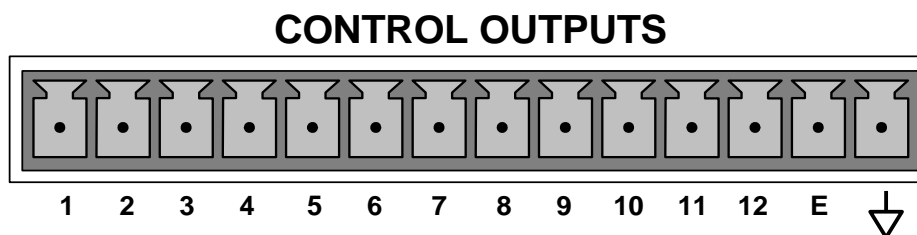

Figure 3-12: Digital Control Output Connector

NOTE

Most PLCs have internal provisions for limiting the current the input will draw. When connecting to a unit that does not have this feature, external resistors must be used to limit the current through the individual transistor outputs to $\leq 50\text{mA}$ ($120\ \Omega$ for 5V supply).

The pin assignments for the control outputs are:

Table 3-5: Control Output Pin Assignments

PIN #	STATUS DEFINITION	CONDITION
1 - 12	Outputs 1 through 12 respectively	Closed if the sequence or sequence step activating output is operating
E	Emitter BUSS	The emitters of the transistors on pins 1 to 8 are bussed together.
⏚	Digital Ground	The ground level from the calibrator's internal DC power supplies.

3.2.6. COMMUNICATION CONNECTIONS

The T-Series instruments are equipped with connectors for remote communications interfaces. This section describes those features.

3.2.6.1. Ethernet Connection

For network or Internet communication with the instrument, connect an Ethernet cable from the instrument's rear panel Ethernet interface connector to an Ethernet port.

The T703 firmware supports dynamic IP addressing or DHCP (default setup) for remote operation via an Ethernet connection. If your network also supports DHCP, the calibrator will automatically configure its LAN connection appropriately (see Section 5.6.1). If your network does not support DHCP, see Section 5.6.1.1 for instructions on manually configuring the LAN connection.

3.2.6.2. USB Option Connection

For direct communication between the instrument and a personal computer (PC), connect a USB cable between the instrument and desktop or laptop USB ports. (If this option is installed, the COM2 port can only be used for RS232 multidrop communication). The Teledyne T-Series USB driver must be installed. See Section 5.5.

3.2.6.3. RS-232 and RS485 Connection

For RS-232 communications through the serial interface COMM ports, refer to Section 5.1.1 of this manual for instructions on configuration and usage. For RS-485 communication, contact the factory.

3.2.6.4. Multidrop Network Connection

If your unit has a Teledyne API RS-232 multidrop card (Option 62), see Section 5.3 for instructions on setting it up.

3.3. PNEUMATIC CONNECTIONS



CAUTION!

Do not operate this instrument until you've removed dust plugs from inlet and outlet/exhaust ports on the rear panel!

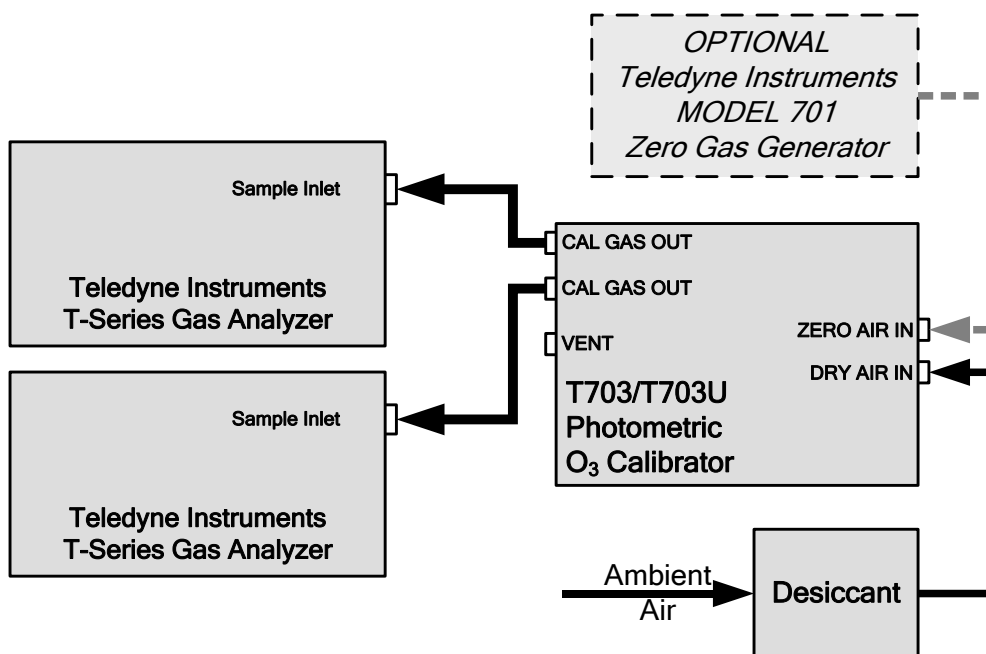

Figure 3-13: Basic Pneumatic Setup

3.3.1. DRY AIR IN

When using the internal zero air pump, a source of dry air should be connected to the port labeled 'Dry Air In' on the rear panel. This air should be supplied at atmospheric pressure. The supplied air should have a dew point of $-20\text{ }^{\circ}\text{C}$ or less.

Teledyne API can supply an optional desiccant cartridge that can be used to supply dry air to the T703/T703U.

3.3.2. ZERO AIR IN

An external pressurized source of zero air can be supplied at the 'Zero Air' port on the rear panel. This is the standard configuration when the zero air pump is not installed. This zero air should be scrubbed of ozone and have a dew point of $-20\text{ }^{\circ}\text{C}$ or less. The pressure of the zero air should be regulated to 20-35 psig.

NOTE

When connecting an external source of zero air to an T703 with an internal zero air pump installed, the zero air pump should be disabled.

The "ZA_PUMP_ENABLE" VAR (see Section 4.10) should be set to OFF.

3.3.3. OUTPUT MANIFOLD

A four-port output manifold is supplied on the rear panel of the T703/T703U enabling simultaneous testing of up to two external instruments. Sample lines for ozone instruments to be calibrated can be connected directly to this manifold.

To prevent ozone exposure, the bottom port of this manifold is used as a vent and should be connected to a proper unpressurized vent manifold. It is important that the backpressure at this vent fitting be kept to a minimum. If a vent line longer than 2 meters (~6 feet) is required, then 3/8" OD tubing should be used.

Any unused ports on this manifold must be capped.

3.3.4. EXHAUST

The port labeled 'EXHAUST' contains the exhaust gas from the internal photometer and may contain ozone. This port should be connected to a proper unpressurized vent manifold to prevent ozone exposure.

3.3.5. MEASURING AN EXTERNAL OZONE SOURCE

The T703/T703U can be configured to measure an external source of ozone.

See Section 4.11 for details on operating the unit in this manner.

3.4. INITIAL OPERATION

If you are unfamiliar with the T703/T703U theory of operation, we recommend that you read Section 9.

For information on navigating the calibrator's software menus, see the menu trees described in Appendix A.

3.4.1. START-UP

After all of the electrical and pneumatic connections are made, turn on the instrument. The exhaust fan and should start immediately. If the instrument is equipped with an internal photometer installed, the associated pump should also start up.

The front panel display will show a splash screen and other information during the initialization process while the CPU loads the operating system, the firmware and the configuration data.

Once the CPU has completed this activity, it will begin loading the calibrator firmware and configuration data. During this process, model and software revision information appear briefly in the Param field of the calibrator's front panel display before the firmware is fully booted:

The calibrator should automatically switch to **STANDBY** mode after completing the boot-up sequence.

3.4.2. WARM UP

The T703/T703U Photometric calibrator requires a minimum of 30 minutes for all of its internal components to reach a stable operating temperature.

3.4.3. WARNING MESSAGES

Because internal temperatures and other conditions may be outside be specified limits during the calibrator’s warm-up period, the software will suppress most warning conditions for 30 minutes after power up. If warning messages persist after the 30 minutes warm up period is over, investigate their cause using the troubleshooting guidelines in Section 8 of this manual.

To view and clear warning messages, press:

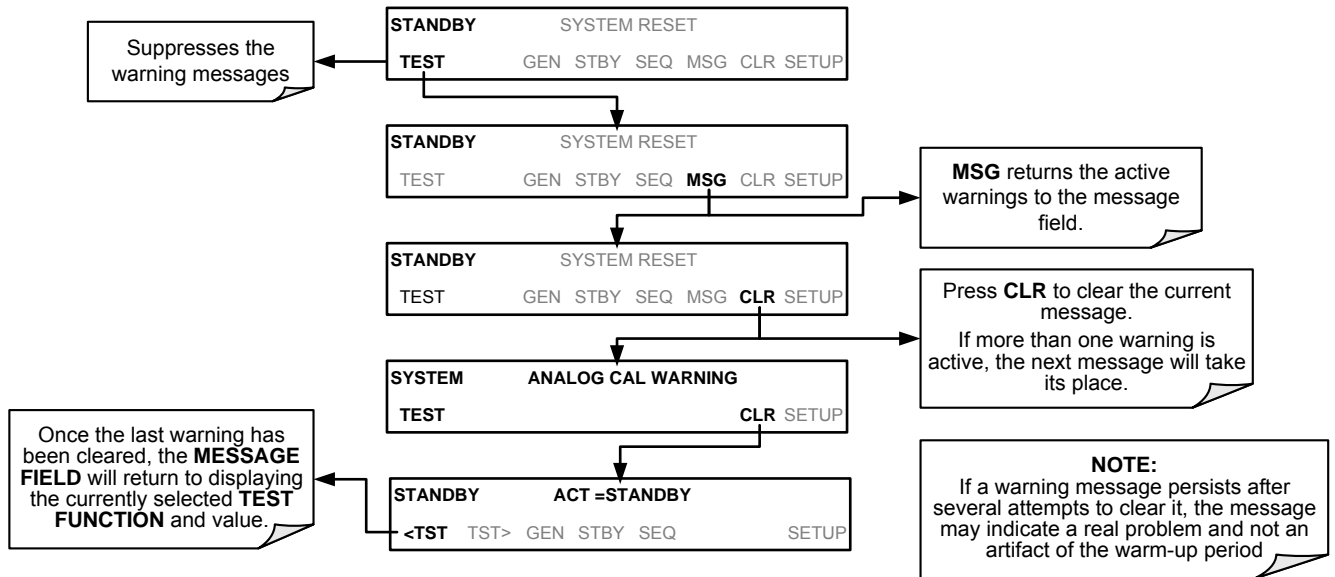

Table 3-6 lists brief descriptions of the warning messages that may occur during start up.

Table 3-6: Possible Warning Messages at Start-Up

MESSAGE	MEANING
ANALOG CAL WARNING	The calibrator's A/D converter or at least one D/A channel has not been calibrated.
CONFIG INITIALIZED	Stored Configuration information has been reset to the factory settings or has been erased.
DATA INITIALIZED	The calibrator's data storage was erased.
LAMP DRIVER WARN	The firmware is unable to communicate with either the O ₃ generator or photometer lamp I ² C driver chips.
O3 GEN LAMP TEMP WARNING	The O ₃ generator lamp temperature is outside of allowable limits.
O3 PUMP WARNING	The pump associated with the O ₃ photometer has failed to turn on.
PHOTO LAMP TEMP WARNING	The photometer lamp temperature is outside of allowable limits.
PHOTO REFERENCE WARNING	The photometer reference reading is outside of allowable limits.
REAR BOARD NOT DET	The calibrator's motherboard was not detected during power up.
RELAY BOARD WARN	The firmware is unable to communicate with the calibrator's relay board.
SYSTEM RESET	The calibrator has been turned off and on or the CPU was reset.

3.4.4. FUNCTIONAL CHECK

1. After the calibrator's components have warmed up for at least 30 minutes, verify that the software properly supports any hardware options that are installed.
2. Check to make sure that the calibrator is functioning within allowable operating parameters. Appendix C includes a list of test functions viewable from the calibrator's front panel as well as their expected values. These functions are also useful tools for diagnosing problems with your calibrator (see Section 8.1.2). The enclosed Final Test and Validation Data sheet (part number 05760) lists these values before the instrument left the factory.

To view the current values of these parameters press the following touch screen button sequence on the calibrator's front panel. Remember until the unit has completed its warm up these parameters may not have stabilized.

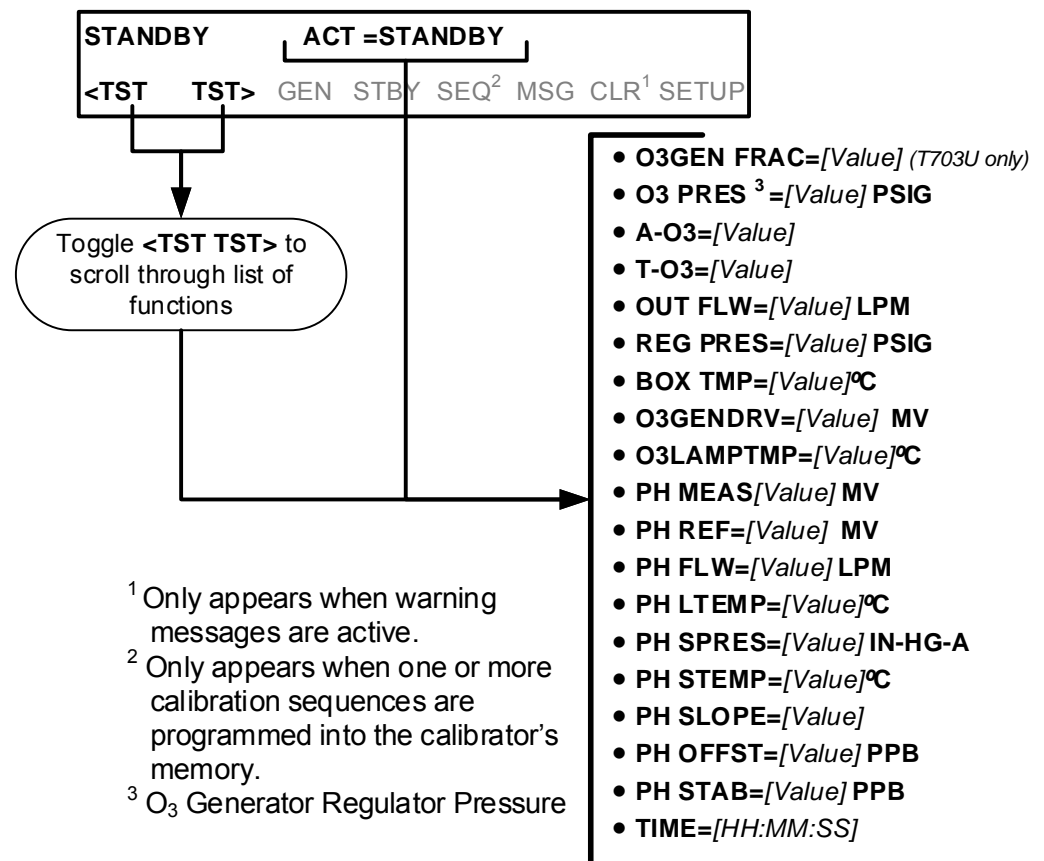

If your calibrator is operating via Ethernet and your network is running a dynamic host configuration protocol (DHCP) software package, the Ethernet option will automatically configure its interface with your LAN. However, it is a good idea to check these settings to make sure that the DHCP has successfully downloaded the appropriate network settings from your network server (See Section 5.6.1).

If your network is not running DHCP, you will have to configure the calibrator's interface manually (See Section 5.6.1.1).

3.4.5. OPERATING MODES FOR THE O₃ GENERATOR

The O₃ generator can be set to operate in three different modes:

3.4.5.1. CNST (CONSTANT)

In this mode, the O₃ output of the generator is based on a single, constant, drive voltage. There is no Feedback loop control by the CPU in this mode.

3.4.5.2. BNCH (BENCH)

The O₃ concentration control loop will use the photometer's O₃ measurement as input.

THIS IS THE DEFAULT AND MOST COMMON MODE OF OPERATION.

This setting will be the default mode of the T703 calibrator and will be used whenever the calibrator is using the GENERATE > AUTO command or the GENERATE sequence step to create a calibration mixture. When either the GENERATE > MAN command or the MANUAL sequence step is active, the local O₃ generator mode (chosen during when the command/step is programmed) will take precedence.

3.4.6. SETTING THE O₃ GENERATOR MODE

To select a default O₃ generator mode, press:

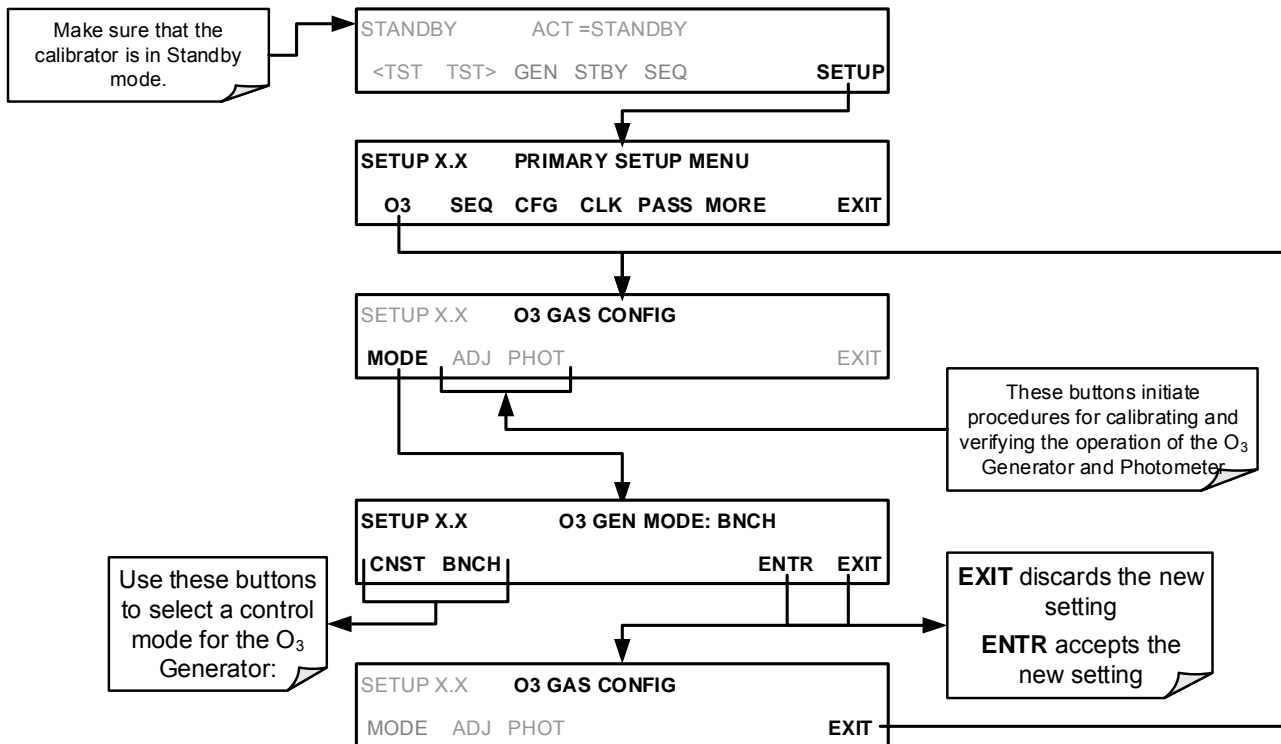

3.4.7. SETTING THE OUTPUT FLOW RATE

The output flow rate must consider both the total gas flow requirements of all analyzers connected to the output manifold and the minimum output flow of the O₃ generator. Figure 3-14 shows a close-up of the regulator assembly.

3.4.7.1. Calculating Output Flow Rate

First, add the sum of the flow requirements of all of the instruments to which the T703/T703U will be supplying calibration gas plus 1 LPM excess flow. For example, if the T703 is expected to supply calibration gas mixtures simultaneously to two analyzers, each requiring 0.8 LPM, the minimum Total Flow output would be:

$$(0.8 + 0.8) + 1.0 = 2.6 \text{ LPM}$$

Second, calculate the flow rate requirements of the O₃ generator output, which must remain above the minimum specification of 20 PPB*LPM. Use the following equation to determine the minimum flow rate (FT) for the O₃ generator output:

$$F_T \geq \frac{20 \text{ ppb} \cdot \text{LPM}}{O_3 \text{ Conc}}$$

Compare the values calculated from the of the above formulae; the greater of the two is the minimum Total Flow that must be set.

3.4.7.2. Output Flow Setup

To set the output flow:

1. Open the front panel of the calibrator by releasing the two snap-in fasteners at the top of the front panel.
2. Pull out the regulator knob and adjust the regulator until the desired flow is achieved.
 - The front panel of the calibrator displays the approximate output flow based on the measured regulator pressure, but this flow should be verified with an independent calibrated flow meter attached to one of the CAL GAS outlets on the back of the instrument (see Figure 3-4).
3. Push the pressure regulator knob (Figure 3-14) back in to lock.
4. Close the front panel.

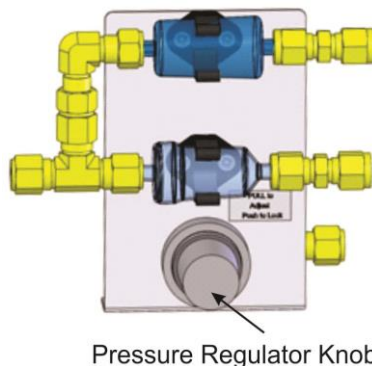

Figure 3-14: Output Pressure Regulator Assembly

4. OPERATING THE CALIBRATOR

The T703/T703U calibrator is a computer-controlled calibrator with a dynamic menu interface for easy, yet powerful and flexible operation. All major operations are controlled from the front panel touch screen control.

To assist in navigating the system's software, a series of menu trees can be found in Appendix A of this manual.

NOTE

The menu flowcharts in this manual depict the manner in which the front panel touchscreen is used to operate the T703/T703U Photometric Calibrator. Please refer to Figure 3-3 for an illustration of how the menu flowcharts correlate to the actual front panel.

The menu flowcharts depict typical representations of the display during the various operations being described; they are not intended to be exact and may differ slightly from the actual display of your system.

NOTE

When editing values in the software, the ENTR button may disappear if you select a value that is invalid or out of the allowable range for that parameter (e.g. such as trying to set the 24-hour clock to 25:00:00). Once you adjust the setting to an allowable value, the ENTR button will re-appear.

4.1. TEST FUNCTIONS

A variety of **TEST FUNCTIONS** are available for viewing at the front panel whenever the calibrator is at the **MAIN MENU**. These measurements provide information about the present operating status of the calibrator and are useful during troubleshooting (see Section 8). Table 6-1 lists the available **TEST** functions.

To view these **TEST** functions, press <**TST** or **TST**> from the main menu and the **Test Functions** will scroll at the top center of the display.

Table 4-1: Test Functions Defined

TEST MEASUREMENT	DESCRIPTION
O3GEN FRAC=X.XX (<i>T703U only</i>)	For low range mode to produce low levels of ozone during a GPT calibration where O ₃ output is <500 PPB LPM (<i>supported only in GEN-AUTO mode</i>)
O3 PRES=XX.X PSIG	O ₃ generator regulator pressure
ACT=GENERATE XX PPB O3	Actual concentration being generated, computed from real-time inputs
TARG=GENERATE XX PPB O3	Target concentration to generate
OUT FLW=X.XXX LPM	Output flow rate (computed from regulator pressure)
REG PRESS=XX.X PSIG	Regulator pressure
BOX TMP=XX.X °C	Internal chassis temperature
O3GENDRV=XXXX.X MV	O ₃ generator lamp drive output
O3LAMPTMP=XX.X °C	O ₃ generator lamp temperature
PH MEAS=XXXX.X MV	Photometer detector measure reading
PH REF=XXXX.X MV	Photometer detector reference reading
PH FLW=X.XXX LPM	Photometer sample flow rate
PH LTEMP=XX.X °C	Photometer lamp temperature
PH SPRES=XX.X IN-HG-A	Photometer sample pressure
PH STEMP=XX.X °C	Photometer sample temperature
PH SLOPE=X.XXX	Photometer slope computed during zero/span bench calibration
PH OFFST=X.X PPB	Photometer offset computed during zero/span bench calibration
PHOTO STABIL=X.X PPB	Photometer concentration stability (standard deviation of 25 bench concentration samples taken 10 seconds apart)
TEST=XXXX.X MV	Value output to <i>TEST_OUTPUT</i> analog output, selected with <i>TEST_CHAN_ID</i> variable
TIME=HH:MM:SS	Current instrument time of day clock. (24 hour format)

4.2. OVERVIEW OF OPERATING MODES

The T703 calibrator software has a variety of operating modes. Most commonly, the calibrator will be operating in **STANDBY** mode. In this mode, the calibrator and all of its subsystems are inactive although **TEST** functions and **WARNING** messages are still updated and can be examined via the front panel display.

The second most important operating mode is **SETUP** mode. This mode is used for performing certain configuration operations, such as programming the concentration of source gases, setting up automatic calibration sequences and configuring the analog / digital inputs and outputs. The **SET UP** mode is also used for accessing various diagnostic tests and functions during troubleshooting.



Figure 4-1: Front Panel Display

The Mode field of the front panel display indicates to the user which operating mode the unit is currently running.

Besides **STANDBY** and **SETUP**, other modes the calibrator can be operated in are:

Table 4-2: Calibrator Operating Modes

MODE	MEANING
DIAG	One of the calibrator's diagnostic modes is being utilized. When those diagnostic functions that have the greatest potential to conflict with generating concentrations are active, the instrument is automatically placed into Standby mode.
GENERATE	In this mode, the instrument is engaged in producing calibration gas.
SETUP¹	SETUP mode is being used to configure the calibrator.
STANDBY	The calibrator is not actively generating gas.
¹ The revision of the Teledyne API software installed in this calibrator will be displayed following the word SETUP . E.g. " SETUP B.4 "	

4.3. STANDBY MODE

When the T703 Photometric Calibrator is in standby mode, it is at rest.

Some functions under the **SETUP > MORE > DIAG** submenu, those which conflict with accurate creation of calibration gas mixtures (e.g. **ANALOG OUTPUT STEP TEST**) automatically place the calibrator into **STANDBY** mode when activated

NOTE

The T703/T703U calibrator should always be placed in **STANDBY** mode when not needed to produce calibration gas.

This can be done manually by pressing the **STBY** button that appears when the calibrator's display is showing the top-level menu (see Figure 4-1).

When programming a calibration sequences the **STANDBY** step should always be inserted at the end of the sequence.

4.4. GENERAL INFORMATION ABOUT THE GENERATE MODE

The GENERATE mode is the mode of operation where the T703/T703U is actively producing calibration gas, either zero or some specified concentration of ozone. In the **GENERATE** mode the Zero Air Pump (if enabled) and Photometer Pump are turned on.

4.4.1. GENERATE > AUTO: BASIC GENERATION OF CALIBRATION GAS

This is the simplest procedure for generating calibration gas mixtures. To generate calibration gas, press

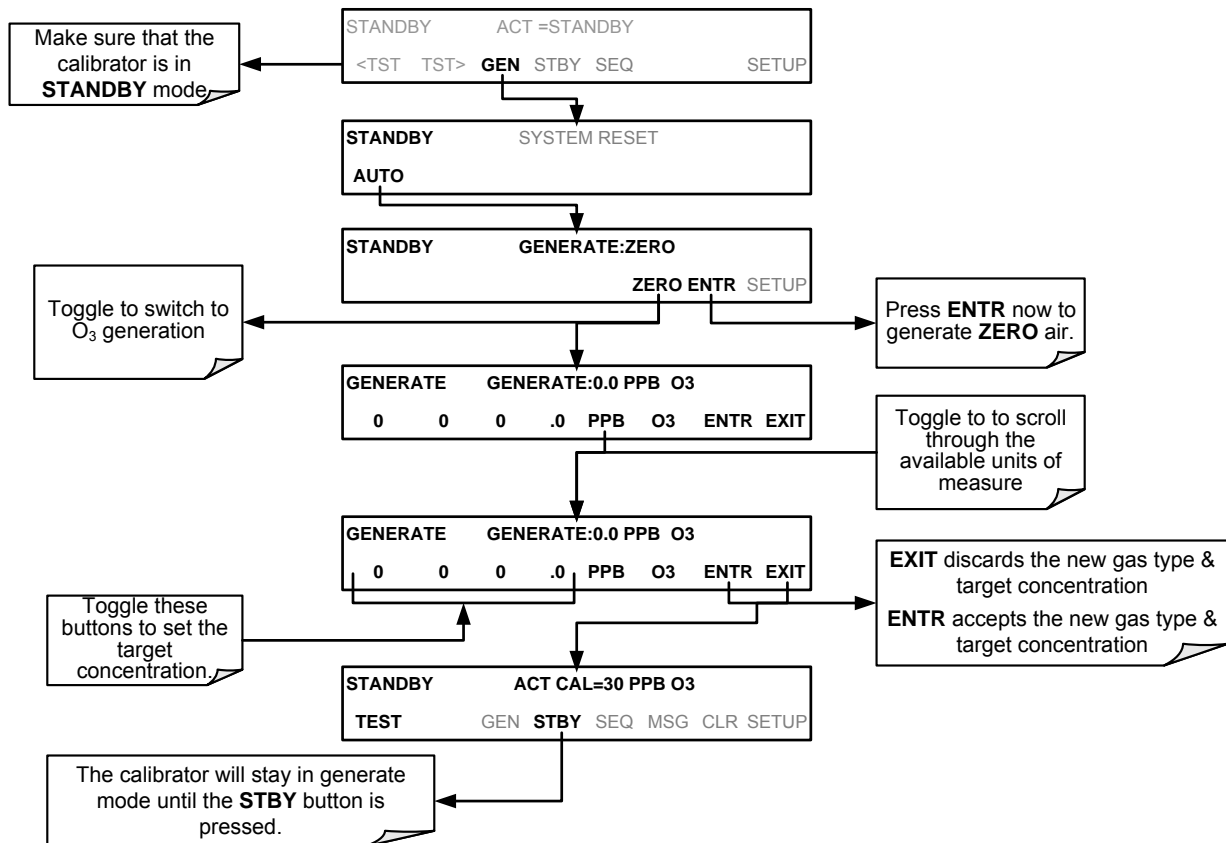

The calibrator will now enter **GENERATE** mode.

4.5. AUTOMATIC CALIBRATION SEQUENCES

The T703/T703U calibrator can be set up to perform automatic calibration sequences of multiple steps. These sequences can perform all of the calibration operations available for manual operation and can be set up to be triggered by using the front panel touch screen buttons, the internal timer, the external digital control inputs, the RS-232 interface, the Ethernet interface or even as sub-processes in another sequence.

4.5.1. SETUP > SEQ: PROGRAMMING CALIBRATION SEQUENCES

A sequence is a database of single or multiple steps where each single step is an instruction that causes the instrument to perform an operation. These steps are grouped under a user-defined **SEQUENCE NAME**.

For each sequence, seven attributes must be programmed; the attributes are presented in Table 4-3.

Table 4-3: Automatic Calibration SEQUENCE Set Up Attributes

ATTRIBUTE NAME	DESCRIPTION
NAME	Allows the user to create a text string of up to 10 characters identifying the sequence.
REPEAT COUNT	Number of times, between 0 and 100, to execute the same sequence. A value of 0 (zero) causes the sequence to execute indefinitely.
CC INPUT	Specifies which of the Digital Control Inputs will initiate the sequence.
CC OUTPUT	Specifies which of the Digital Control Outputs will be set when the sequence is active.
TIMER ENABLE	Enables or disables an internal automatic timer that can initiate sequences using the calibrator's built in clock.
STEPS	A series of submenus for programming the activities and instructions that make up the calibration sequence.
PROGRESS MODE	Allows the user to select the reporting style the calibrator uses to report the progress of the sequences, on the front panels display, as it runs

The types of instruction steps available for creating calibration sequences are presented in Table 4-4:

Table 4-4: Calibration SEQUENCE Step Instruction

INSTRUCTION NAME	DESCRIPTION
GENERATE	Puts the instrument into GENERATE mode. Similar in operation and effect to the GENERATE > AUTO function used at the front panel.
DURATION	Adds a period of time between the previous instruction and the next
EXECSEQ	Calls another sequence to be executed at this time. The calling sequence will resume running when the called sequence is completed. Up to 5 levels of nested sequences can be programmed.
SETCCOUTPUT	Allows the sequence to activate the digital control outputs. Similar to the CC OUPUT attribute, but can be set and reset by individual steps.

NOTE

It is recommended that each calibration sequence be ended with an instruction to return the instrument to **STANDBY mode.**

To create a sequence, use the instructions in the following sections to name the sequence, set its associated parameters and define the steps to be included.

4.5.1.1. Activating a Sequence from the T703/T703U Front Panel

To activate an already programmed sequence from the front panel, press:

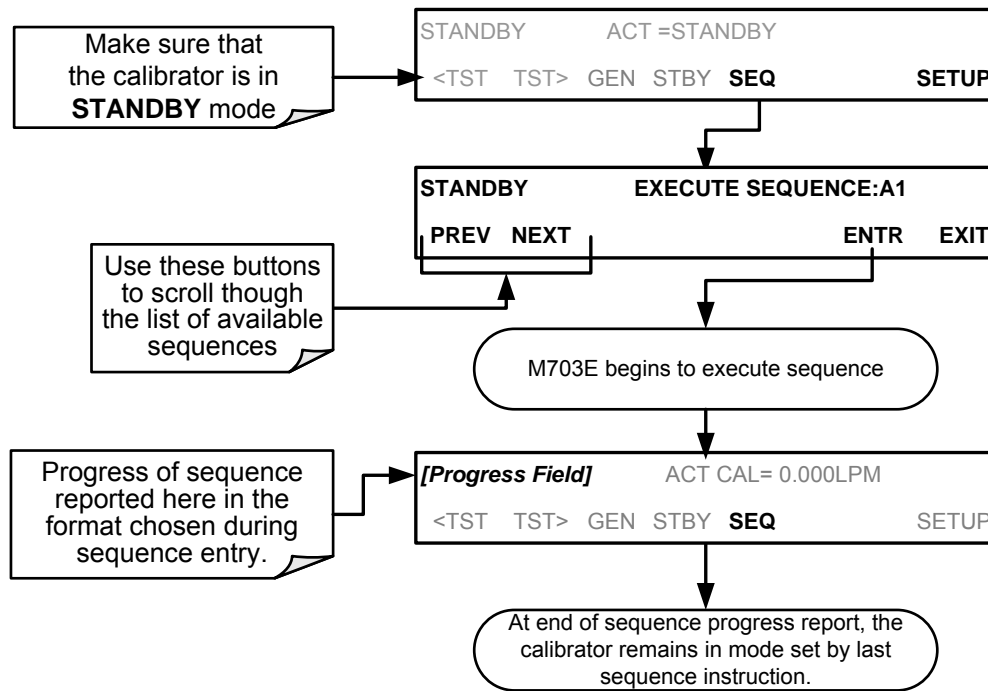

4.5.1.2. Naming a Sequence

The first step of creating a calibration sequence is to assign it a name. The name can be up to 10 characters and can be comprised of any alpha character (A to Z), and numeral (0 to 9) or the underscore character (“_”).

To assign a name to a sequence, press,

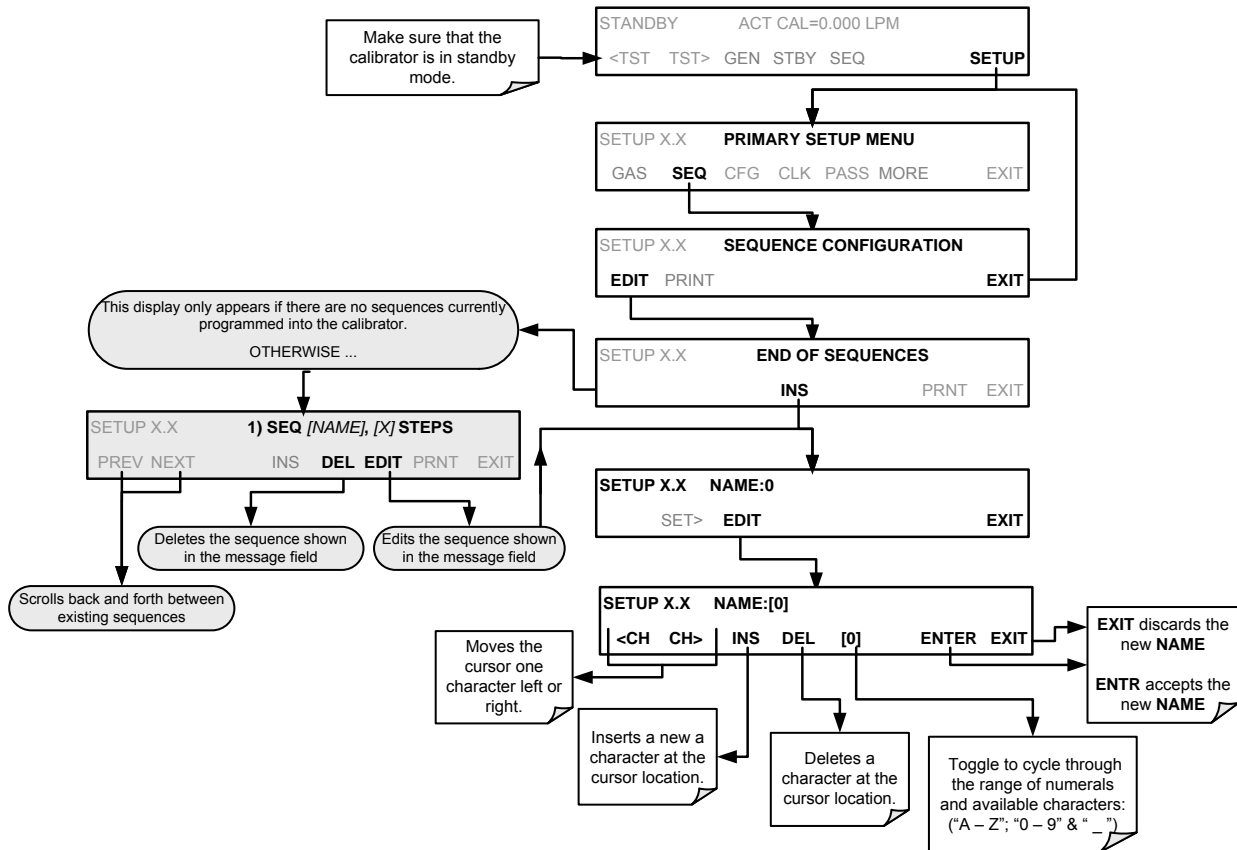

4.5.1.3. Setting the Repeat Count for a Sequence

The sequence can be set to repeat a certain number of times, from 1 to 100. It can also be set to repeat indefinitely by inputting a zero (0) into the **REPEAT COUNTER**.

To set the **REPEAT COUNTER**, press:

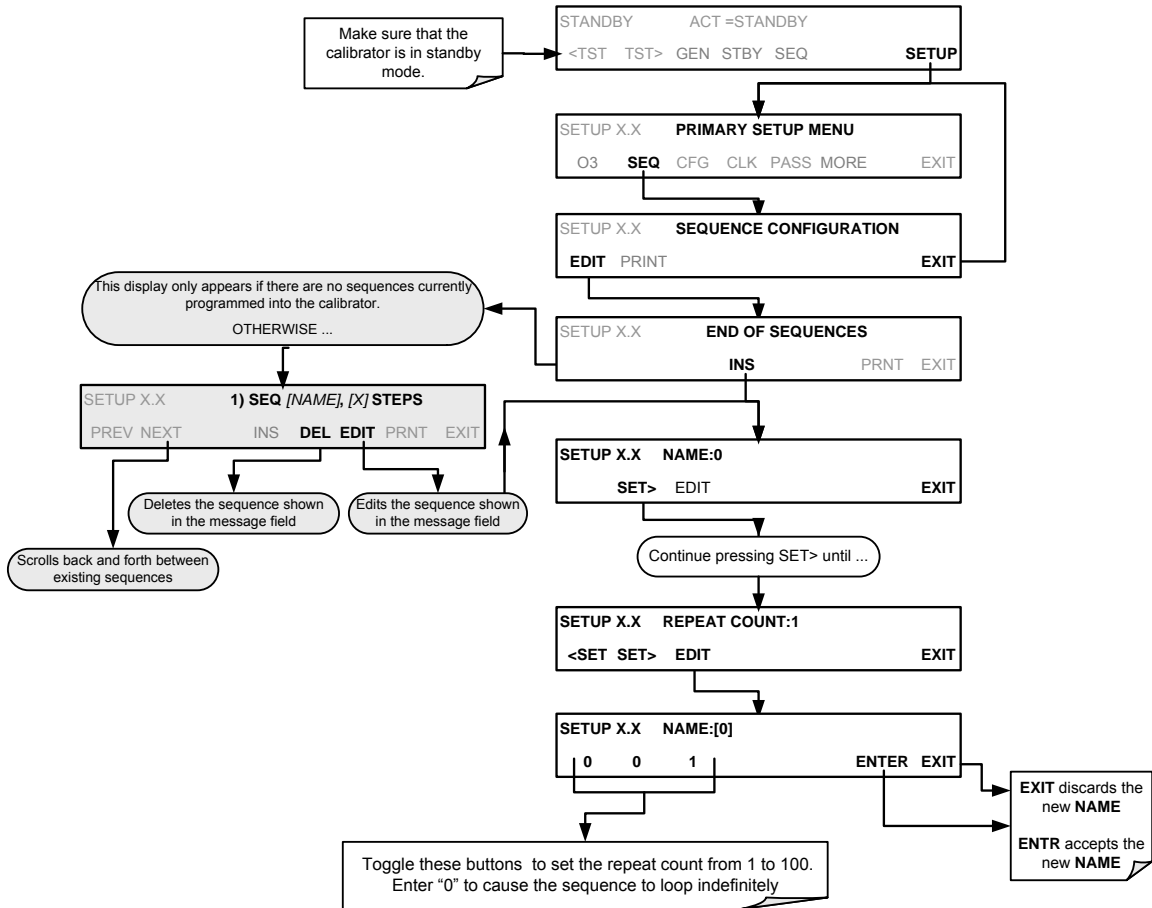

4.5.1.4. Using the Internal Clock to Trigger Sequences

Sequences can be set to trigger based on the internal clock. The sequence can be set up to start at a predetermined date and time. It can also be set to repeat after a predetermined delay time.

So activate and sequence timer, press:

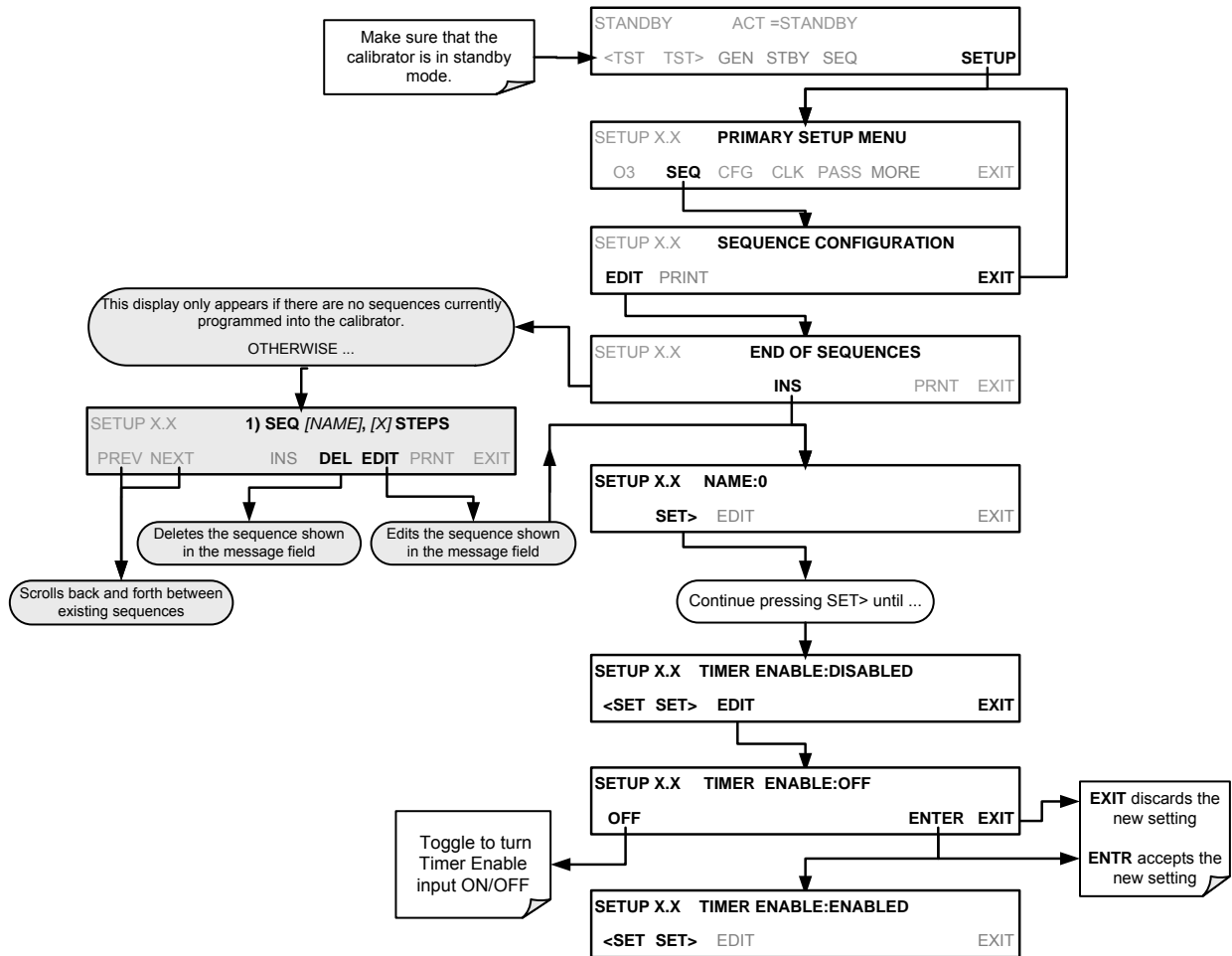

To specify a starting time for the sequence, press:

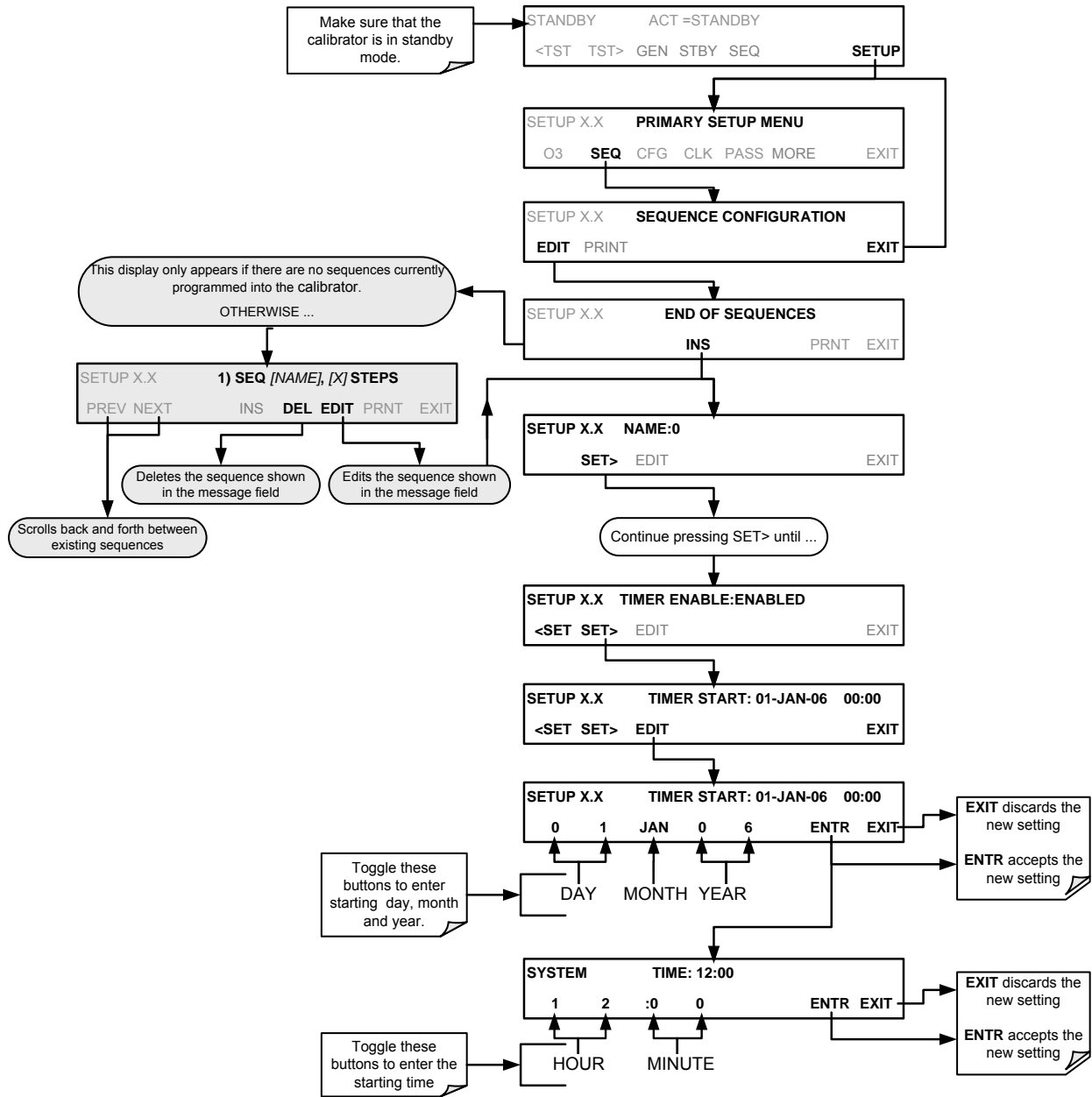

To set the delta timer, press:

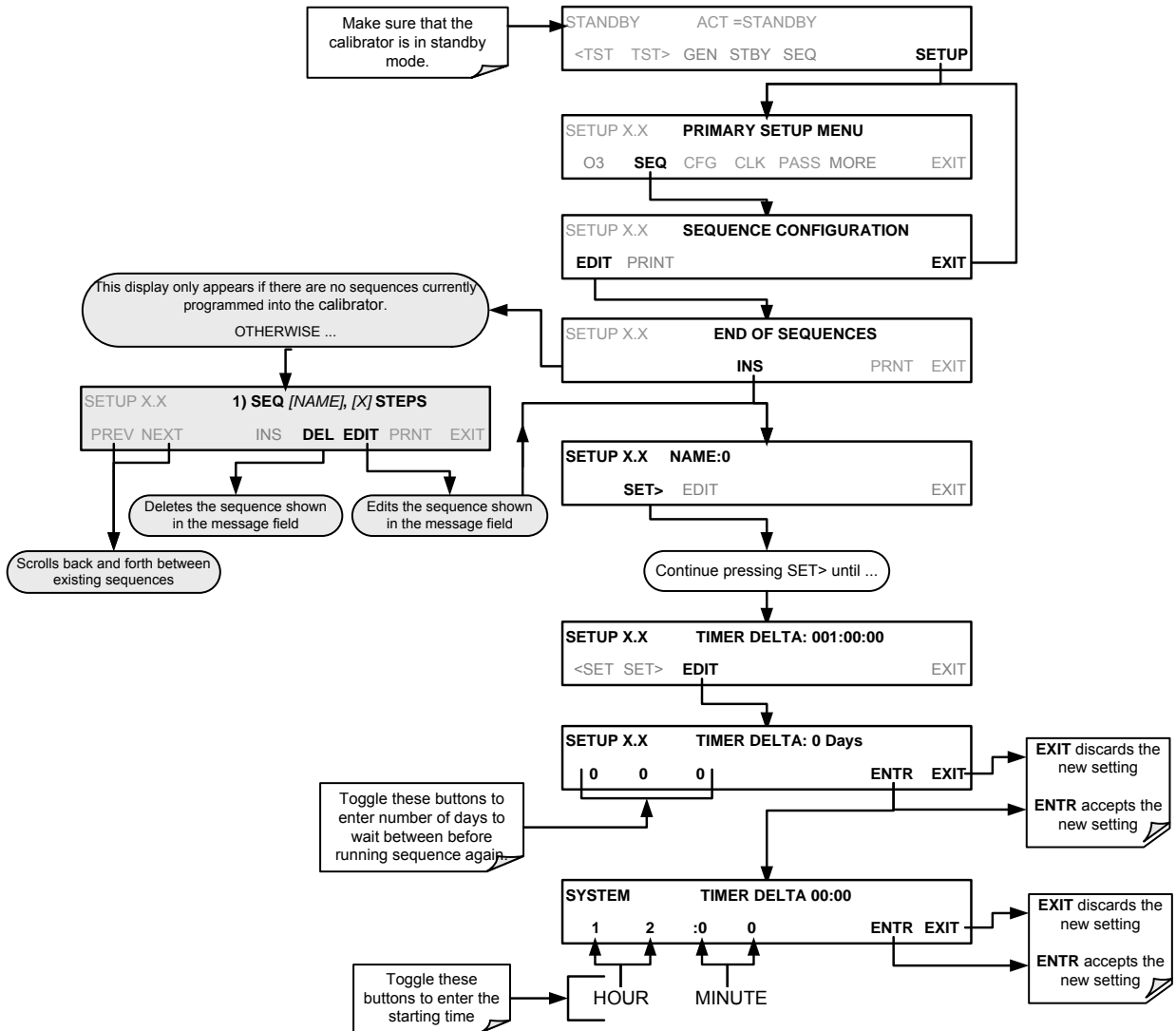

4.5.1.5. Setting Up Control Inputs for a Sequence

The calibrator’s control inputs allow the entire sequence to be triggered from an external source. This feature allows the calibrator to operate in a slave mode so that external control sources, such as a data logger can initiate the calibration sequences.

Each of the calibrator’s control outputs, located on the back of the instrument (see Figure 3-2)

- 12 separate ON/OFF switches assigned to separate calibration sequences or;
- A 12-bit wide bus allowing the user to define activation codes for up to 4095 separate calibration sequences.

To assign a **CC INPUT** pattern / code to a particular sequence, press.

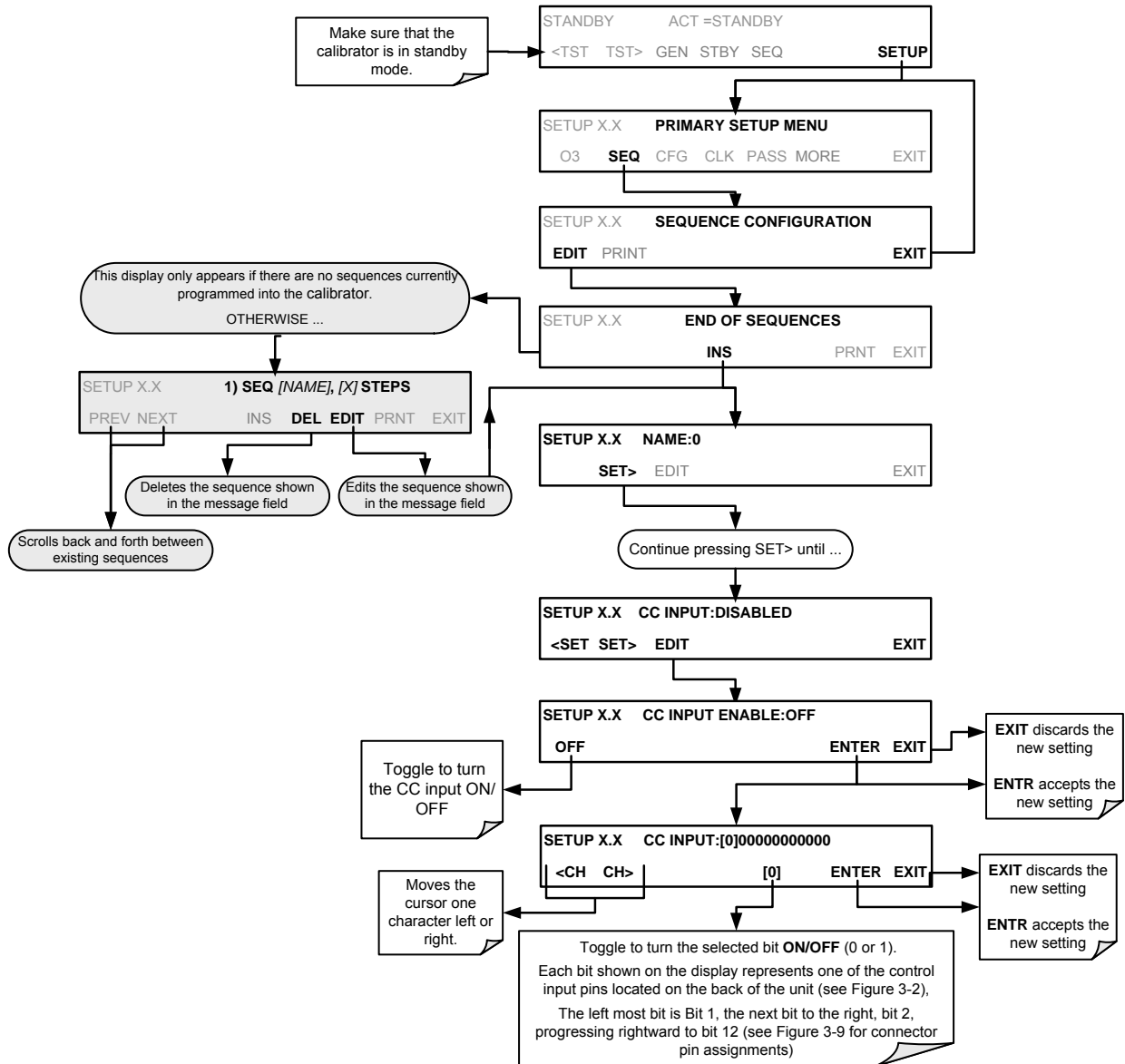

4.5.1.6. Setting Up Control Outputs for a Sequence

The calibrator’s control outputs allow the entire sequence to be triggered from an external source. This feature allows the calibrator to control devices that accept logic-level digital inputs, such as programmable logic controllers (PLCs), dataloggers, or digital relays/valve drivers.

They can be used as:

- 12 separate ON/OFF switches assigned to separate calibration sequences, or;
- A 12-bit wide bus allowing the user to define activation codes for up to 4095 separate calibration sequences.

They can be set to:

- Be active whenever a particular calibration sequence is operating, or;
- Activate/deactivate as individual steps within a calibration sequence are run (See Section 4.5.2.5).

To assign a **CC OUTPUT** pattern / code to a particular sequence, press.

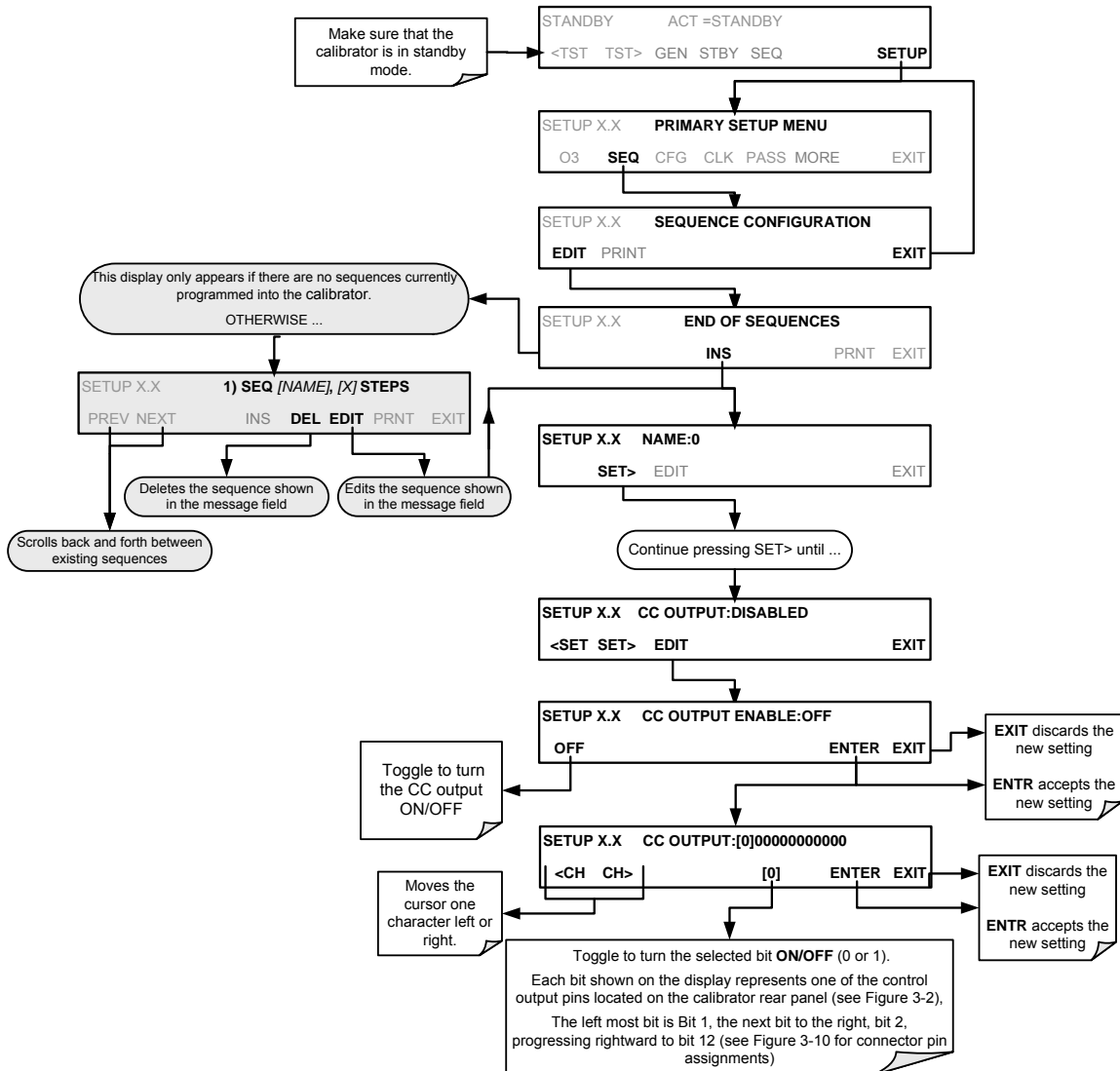

4.5.1.7. Setting the Progress Reporting Mode for the Sequences

As sequences run, the calibrator reports progress by displaying a message in the MODE field of the front panel display (See Figure 3-1). There are several types of report modes available

Table 4-5: Sequence Progress Reporting Mode

MODE	DESCRIPTION
STEP	<ul style="list-style-type: none"> Shows the progress as the sequence name and step number. This is the traditional display. Example: "SO2_Test-2".
PCT	<ul style="list-style-type: none"> Shows the progress as a percent (0–100%) of the total sequence duration. Example: "SEQ 48%"
ELAP	<ul style="list-style-type: none"> Shows the progress as days, hours, minutes and seconds elapsed, counting up from 0. Example (<1 day): "T+01:30:25" (i.e. 1 hour, 30 minutes, 25 seconds elapsed) Example (>=1 day): "T+1d30:25" (i.e. 1 day, 30 hours, 25 minutes elapsed)
REM	<ul style="list-style-type: none"> Shows the progress as days, hours, minutes, and seconds remaining, counting down to 0. Example (<1 day): "T-01:30:25" (i.e. 1 hour, 30 minutes, 25 seconds remaining) Example (>=1 day): "T-1d30:25" (i.e. 1 day, 30 hours, 25 minutes remaining)

To select a PROGRESS report mode, press:

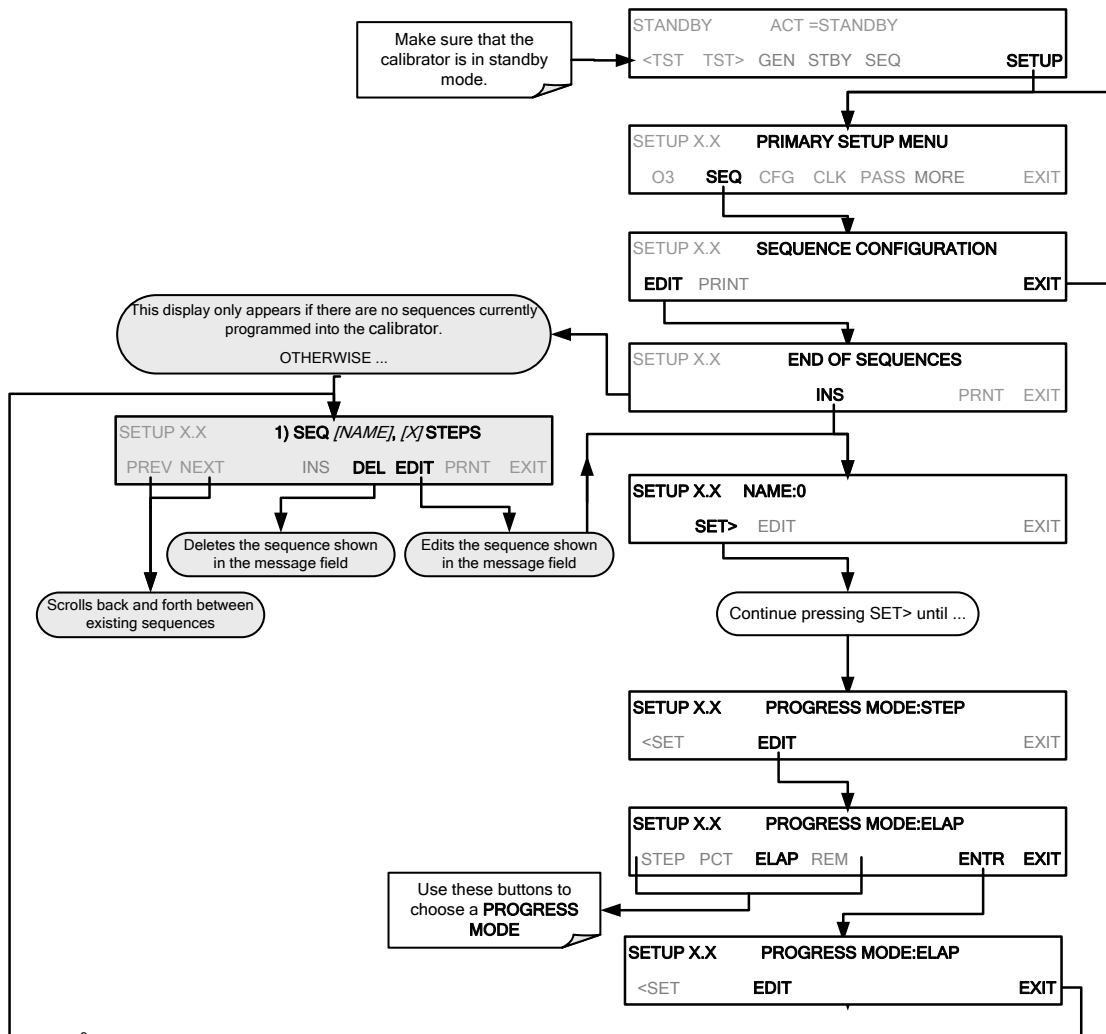

4.5.2. ADDING SEQUENCE STEPS

To insert an instruction step into a sequence, navigate to the **INSERT STEP** submenu by pressing:

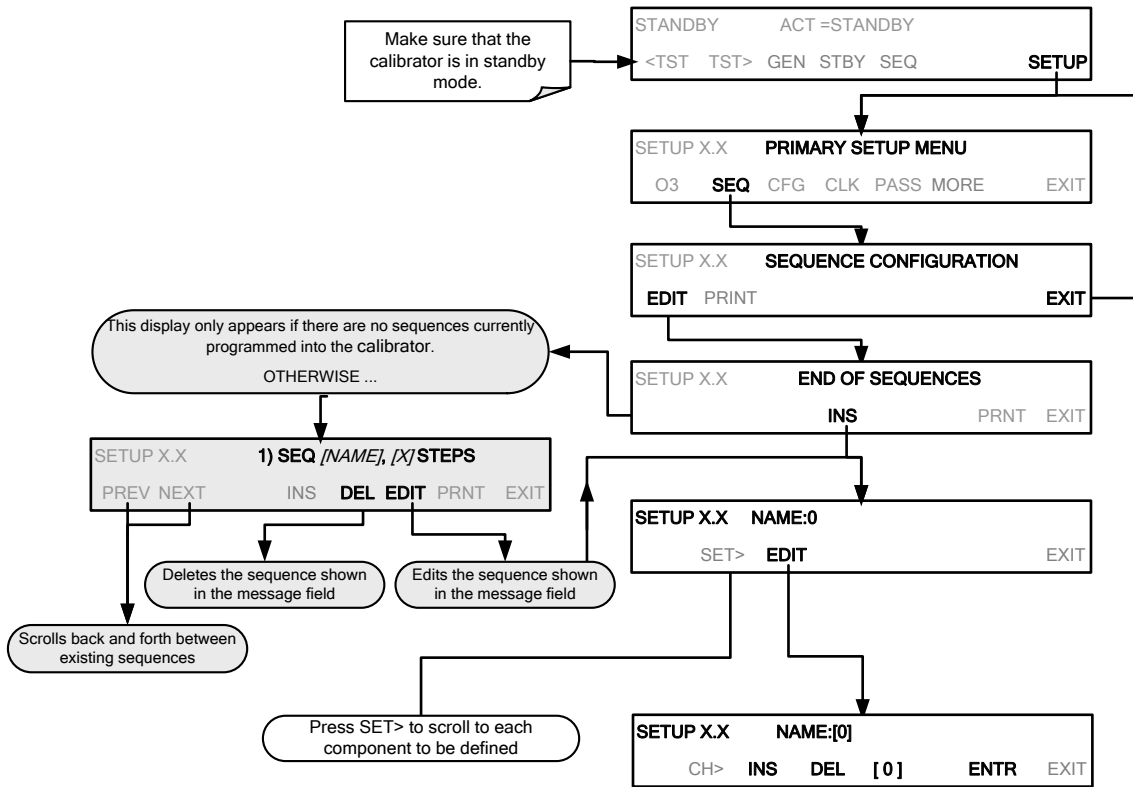

4.5.2.1. The GENERATE Step

This step operates and is programmed similarly to the **GENERATE > AUTO**.

At the end of the programming sequence, the T703/T703U firmware will automatically insert a **DURATION** step that needs to be defined.

To insert a **GENERATE** step into a sequence, press:

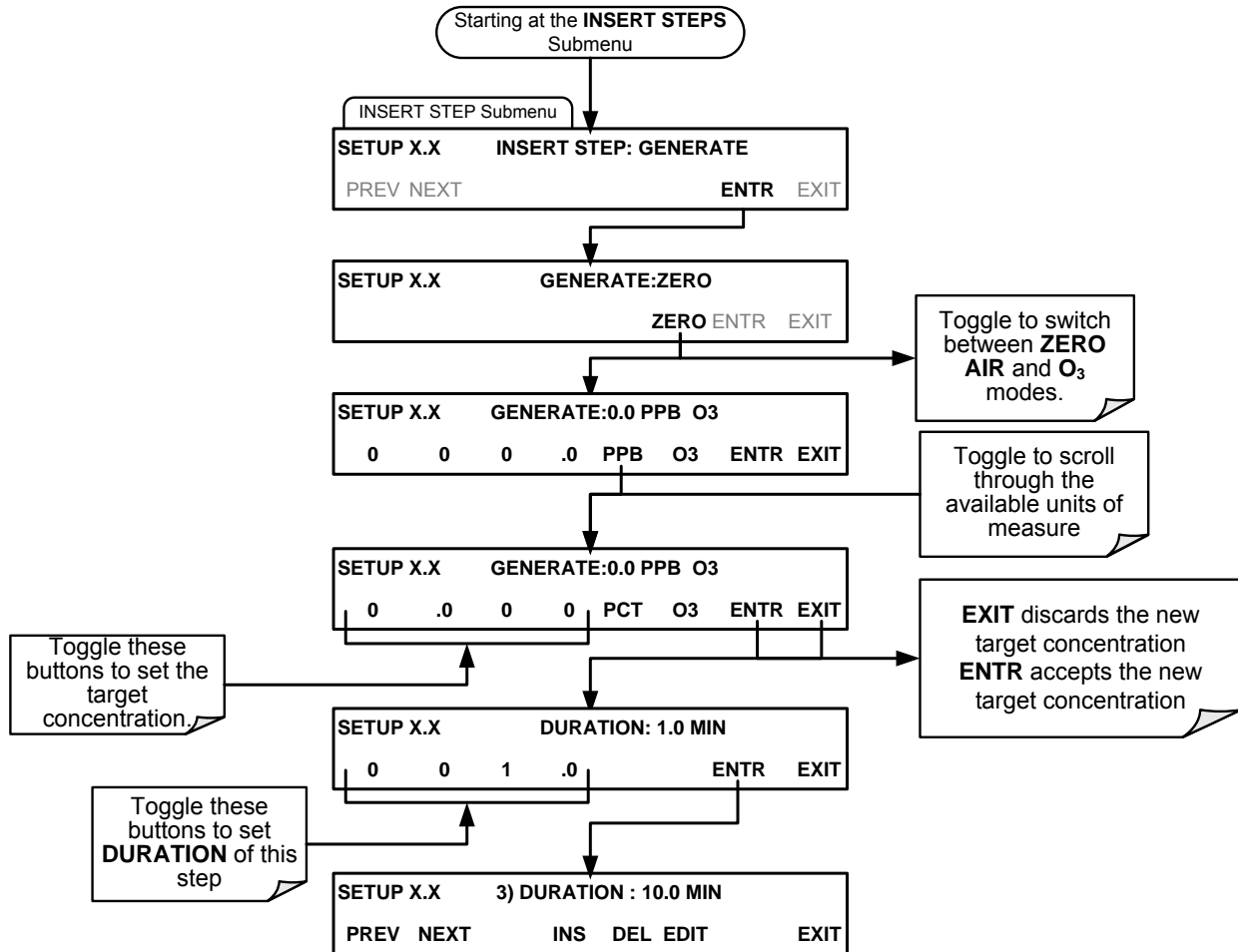

4.5.2.2. The **STANDBY** Step

The **STANDBY** step places the calibrator into **STANDBY** mode

To insert a **STANDBY** step into a sequence, press:

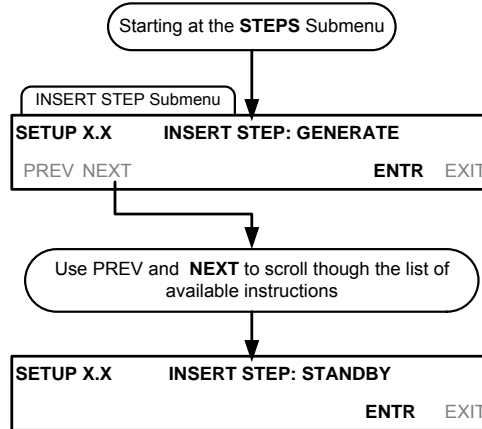

4.5.2.3. The **DURATION** Step

The duration step causes the T703/T703U to continue performing whatever action was called for by the preceding step of the sequence.

- If that step put the instrument into **STANDBY** mode, the calibrator stays in **STANDBY** mode for the period specified by the **DURATION** step,
- If that step put the instrument into **GENERATE** mode, the will continue to **GENERATE** whatever calibration mixture was programmed into that step for the period specified by the **DURATION** step,

To insert a **DURATION** step into a sequence, press:

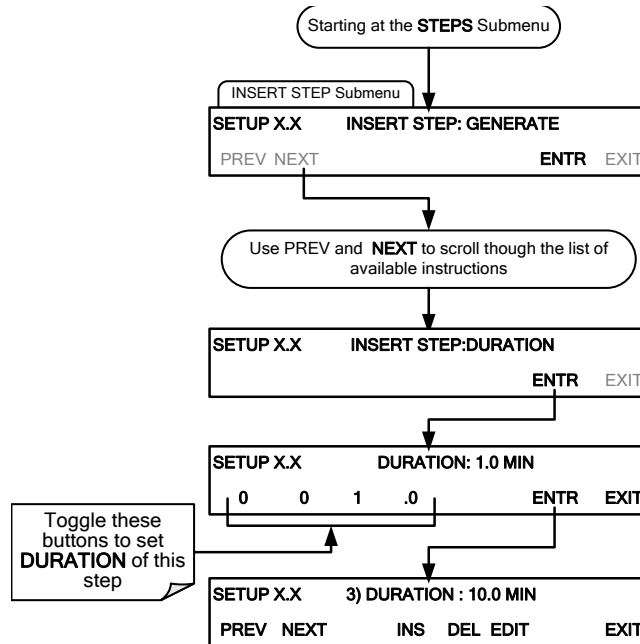

4.5.2.4. The EXECSEQ Step

The **EXECSEQ** step allows the sequence to call another, already programmed sequence. This is a very powerful tool in that it allows the user to create a “toolbox” of often-used operations that can then be mixed and matched by an overhead sequence:

To insert an **EXECSEQ** step into a sequence, press:

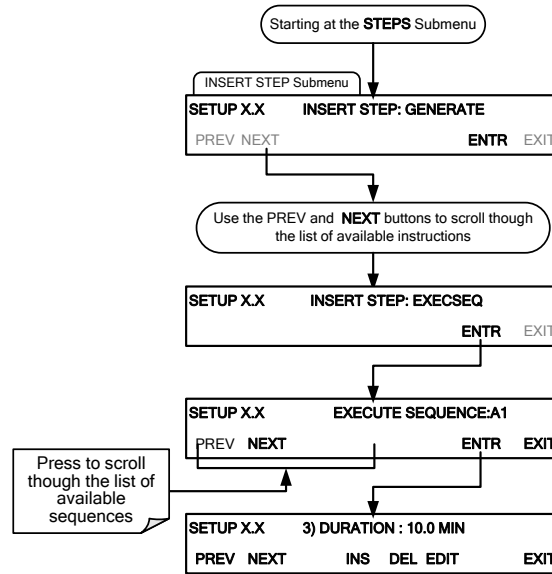

4.5.2.5. The CC OUTPUT Step

This instruction causes the sequence to set or reset the calibrator’s digital control outputs. It is very useful in situations where the control outputs are being used to trigger other devices that need to be turned off and on in synch with the operation of the calibrator as it progress through the sequence.

To insert a **CC OUTPUT** step into a sequence, press:

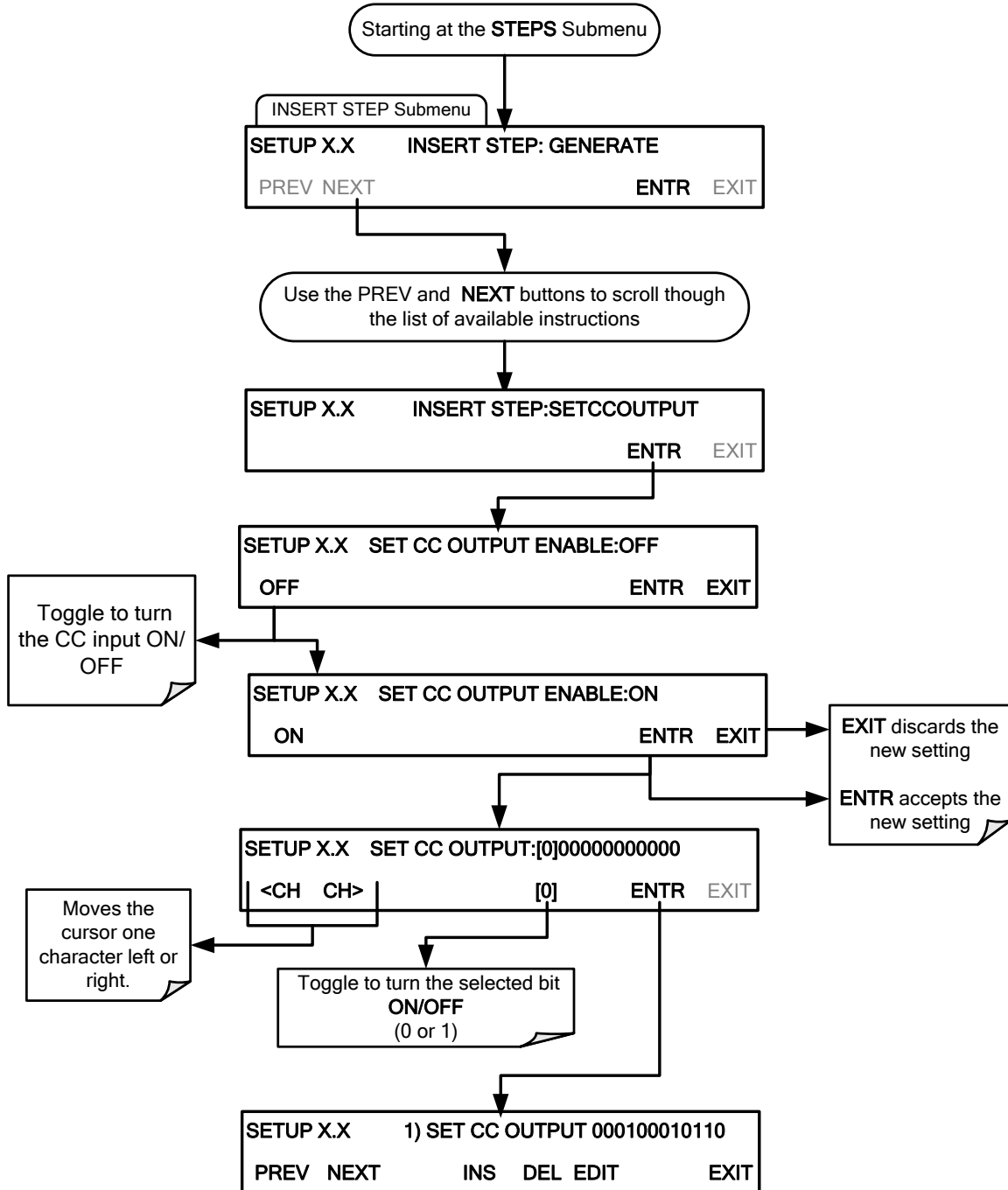

4.5.2.6. Deleting or Editing an Individual Step in a Sequence

To delete or edit an individual step in an existing Sequence, press:

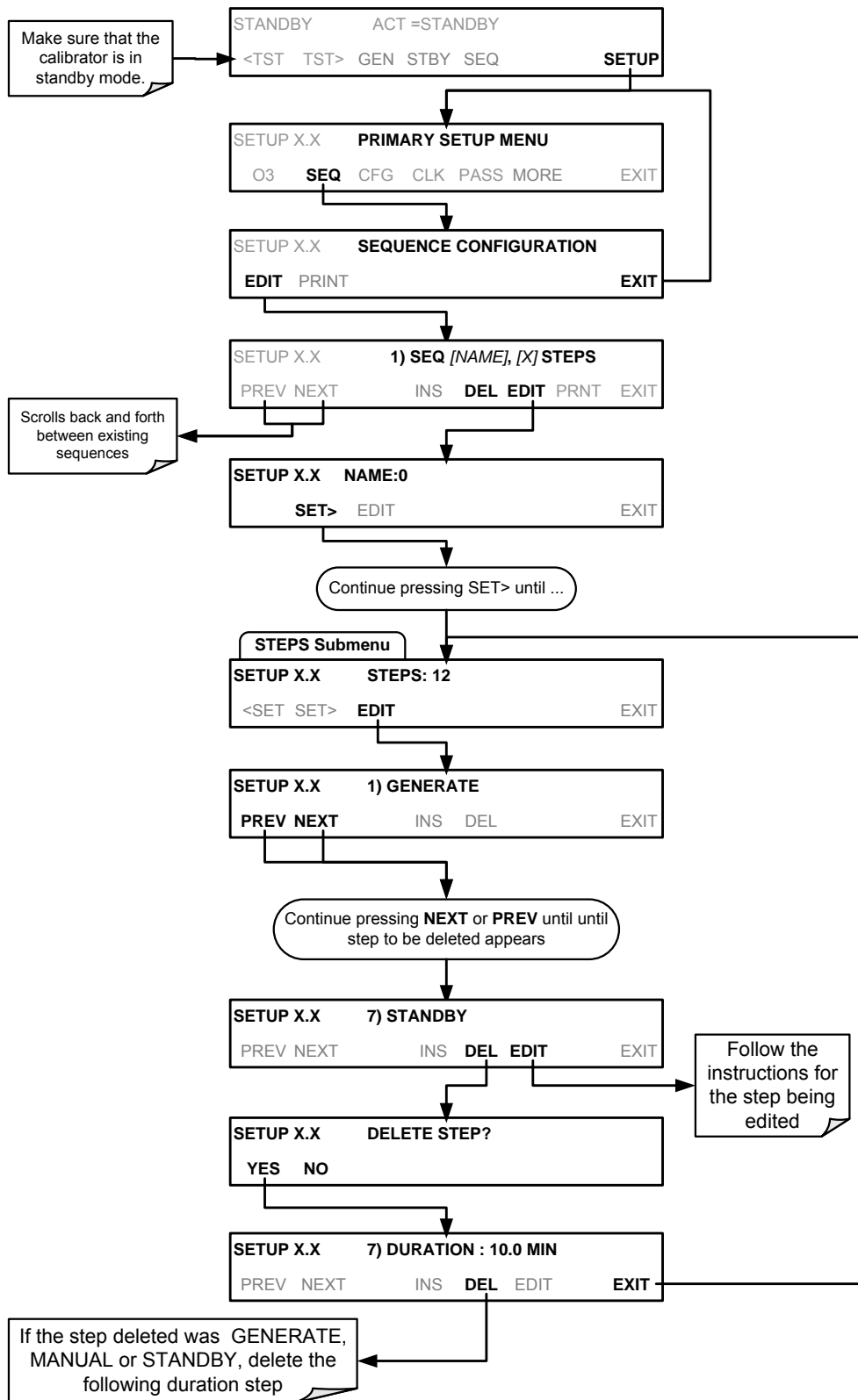

4.5.3. DELETING A SEQUENCE

To delete a sequence from the calibrator's memory, press:

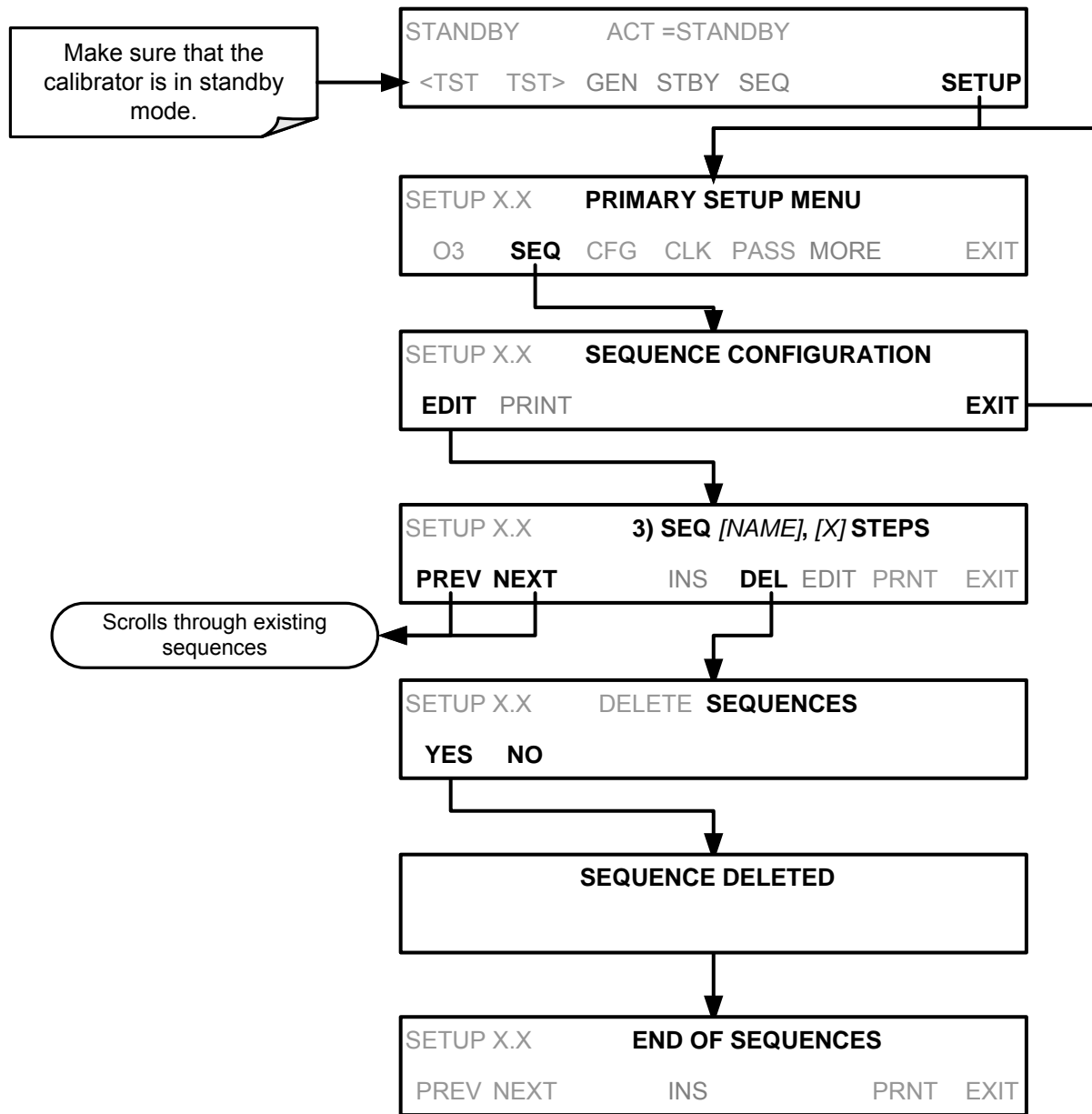

4.6. SETUP > CFG

Pressing the CFG button displays the instrument’s configuration information. This display lists the calibrator model, serial number, firmware revision, software library revision, CPU type and other information.

Use this information to identify the software and hardware when contacting Technical Support.

Special instrument or software features or installed options may also be listed here.

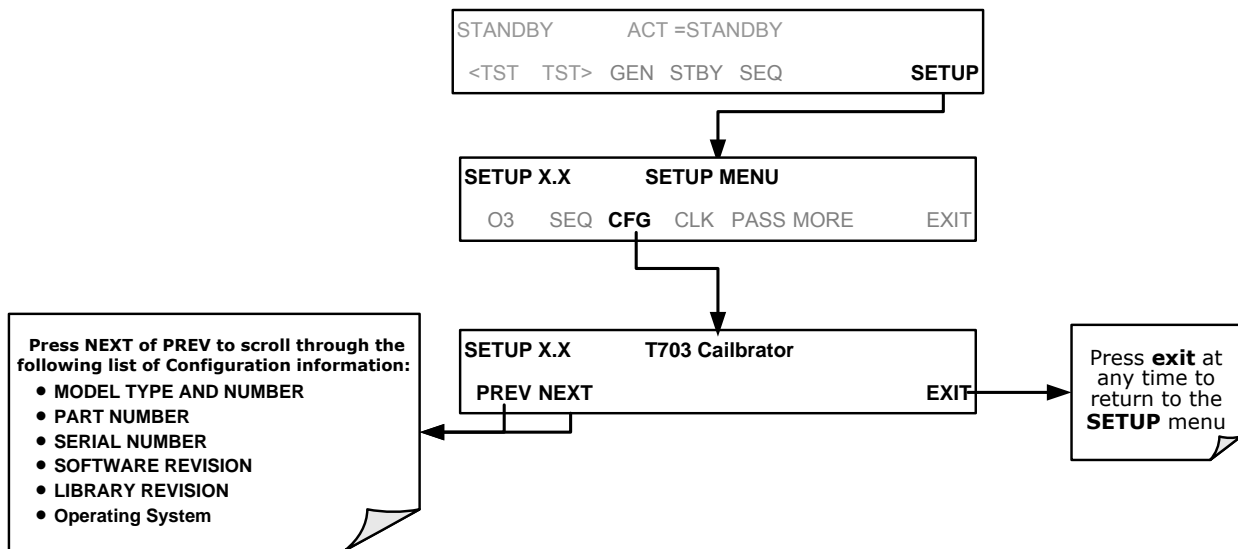

4.7. SETUP > CLK

4.7.1. SETTING THE INTERNAL CLOCK'S TIME AND DAY

The T703/T703U has a time of day clock that supports the **DURATION** step of the calibration sequence feature, time of day TEST function, and time stamps on most COM port messages. To set the clock's time and day, press:

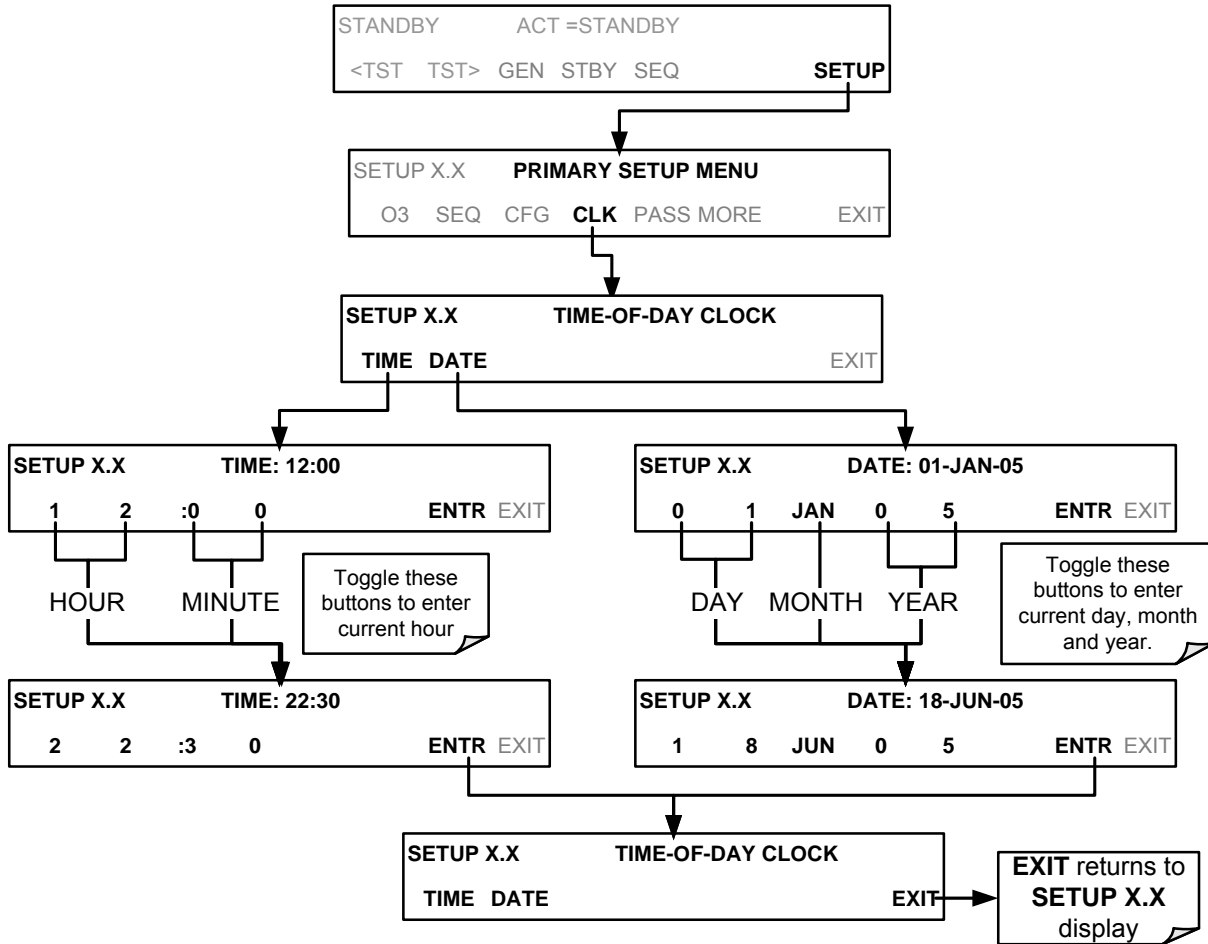

4.7.2. ADJUSTING THE INTERNAL CLOCK'S SPEED

In order to compensate for CPU clocks which run faster or slower, you can adjust a variable called **CLOCK_ADJ** to speed up or slow down the clock by a fixed amount every day. To change this variable, press:

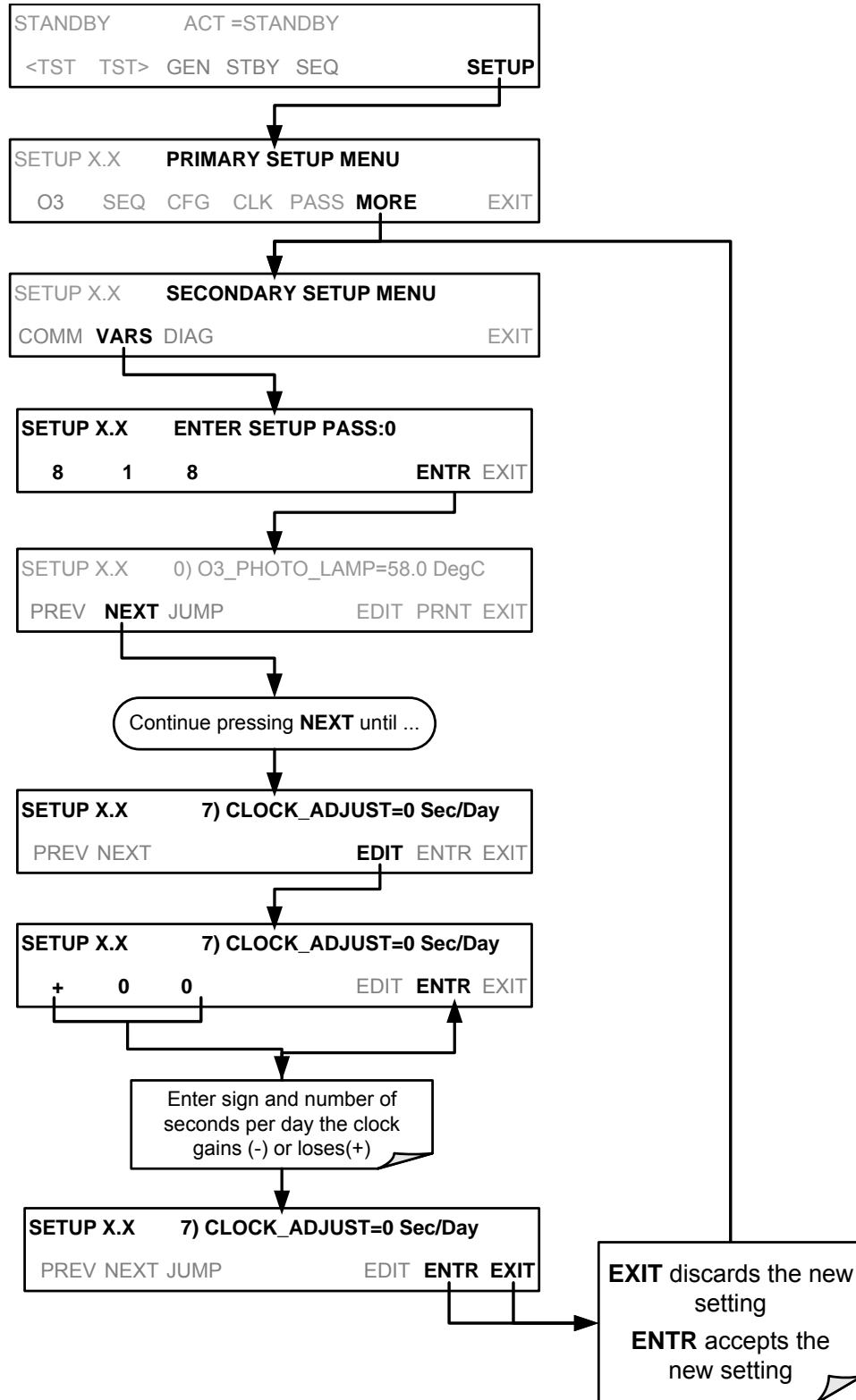

4.8. SETUP > PASS

The menu system provides password protection of the calibration and setup functions to prevent unauthorized adjustments. When the passwords have been enabled in the **PASS** menu item, the system will prompt the user for a password anytime a password-protected function (e.g., **SETUP**) is selected. This allows normal operation of the instrument, but requires the password (101) to access to the menus under **SETUP**. When **PASSWORD** is disabled (**SETUP>OFF**), any operator can enter the Primary Setup (**SETUP**) and Secondary Setup (**SETUP>MORE**) menus. Whether **PASSWORD** is enabled or disabled, a password (default 818) is required to enter the **VAR**s or **DIAG** menus in the **SETUP>MORE** menu.

Table 4-6: Password Levels

PASSWORD	LEVEL	MENU ACCESS ALLOWED
Null (000)	Operation	All functions of the main menu (top level, or Primary, menu)
101	Configuration/Maintenance	Access to Primary and Secondary SETUP Menus when PASSWORD is enabled
818	Configuration/Maintenance	Access to Secondary SETUP Submenus VAR s and DIAG whether PASSWORD is enabled or disabled.

To enable or disable passwords, press:

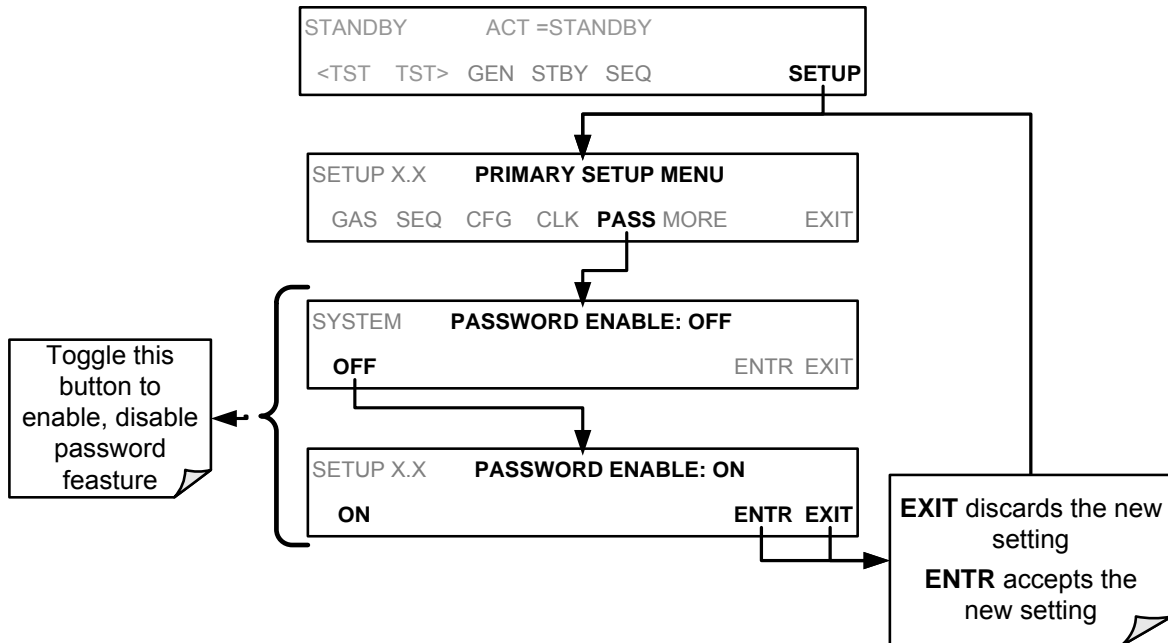

Example: If all passwords are enabled, the following menu button sequence would be required to enter the VARS or DIAG submenus:

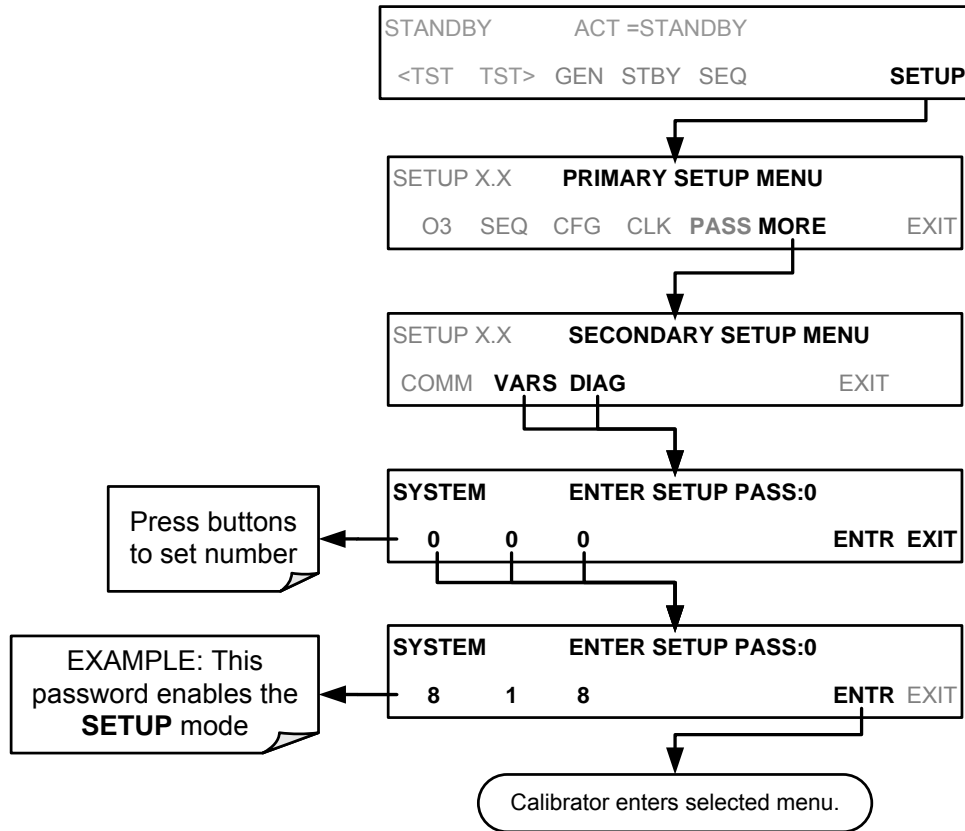

NOTE

The instrument still prompts for a password when entering the VARS and DIAG menus, even if passwords are disabled, but it displays the default password (818) upon entering these menus. The user only has to press ENTR to access the password-protected menus but does not have to enter the required number code.

4.9. SETUP > DIAG > TEST CHAN OUTPUT: USING THE TEST CHANNEL ANALOG OUTPUT

The calibrator comes equipped with one analog output. It can be set by the user to carry the current signal level of any one of the parameters listed in Table 4-8 and will output an analog VDC signal that rises and falls in relationship with the value of the parameter.

Pin-outs for the analog output connector at the rear panel of the instrument are:

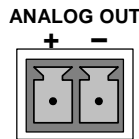

Figure 4-2: TEST CHANNEL Connector

4.9.1. CONFIGURING THE TEST CHANNEL ANALOG OUTPUT

4.9.1.1. The Analog I/O Configuration Submenu

Table 4-7 lists the analog I/O functions that are available in the calibrator.

Table 4-7: DIAG - Analog I/O Functions

SUB MENU	FUNCTION
AOUTS CALIBRATED:	Shows the status of the analog output calibration (YES/NO) and initiates a calibration of all analog output channels.
CAL_OUT_1:	NOT USED ON THE T703
CAL_OUT_2	
TEST OUTPUT	Configures the 11 analog output: RANGE ¹ : Selects the DCV full-scale value of the output. OVERRANGE : Turns the ± 5% over-range feature ON/OFF for this output channel. REC_OFS ¹ : Sets a voltage offset (not available when RANGE is set to CURRENT loop. AUTO_CAL ¹ : Sets the channel for automatic or manual calibration CALIBRATED ¹ : Performs the same calibration as AOUT CALIBRATED , but on this one channel only.
AIN CALIBRATED	Shows the calibration status (YES/NO) and initiates a calibration of the analog to digital converter circuit on the motherboard.
¹ Changes to RANGE or REC_OFS require recalibration of this output.	

To configure the instrument's **TEST CHANNEL**, set the electronic signal type of each channel and calibrate the outputs. This consists of:

1. Choosing a **TEST CHANNEL** function to be output on the channel.
2. Selecting a signal level that matches the input requirements of the recording device attached to the channel.
3. Determining if the over-range feature is needed and turn it on or off accordingly.
4. Adding a bipolar recorder offset to the signal if required (Section 4.9.1.5).
5. Calibrating the output channel. This can be done automatically or manually for each channel (see Section 4.9.2).

To access the analog I/O configuration sub menu, press:

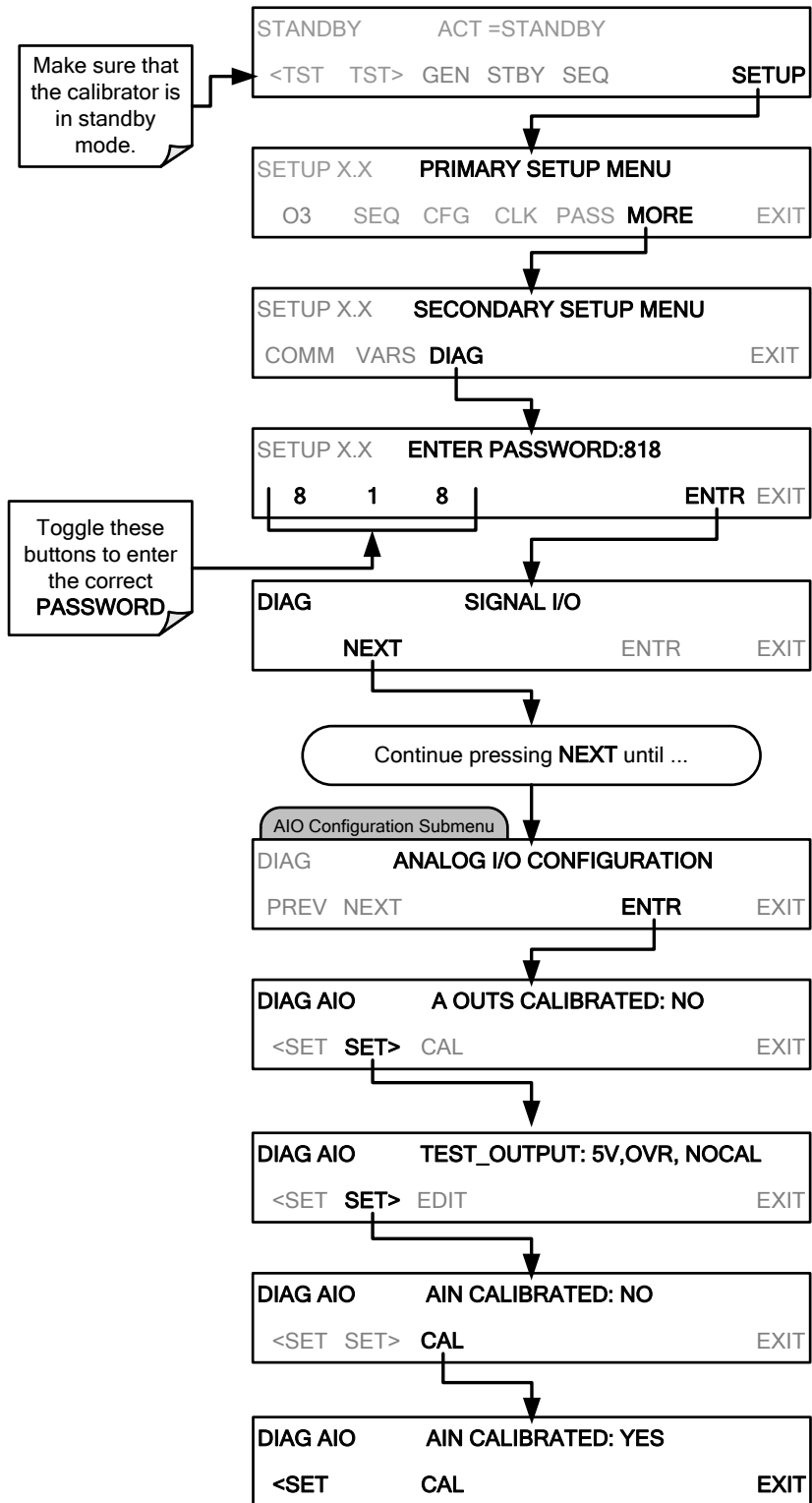

4.9.1.2. Selecting a TEST Channel Function to Output

The Test Functions available to be reported are:

Table 4-8: Test Channels Functions Available on the Analog Output

TEST CHANNEL	DESCRIPTION	ZERO	FULL SCALE
NONE	TEST CHANNEL IS TURNED OFF		
O3 PHOTO MEAS	The raw output of the photometer during its measure cycle	0 mV	5000 mV*
O3 PHOTO REF	The raw output of the photometer during its reference cycle	0 mV	5000 mV*
OUTPUT FLOW	The gas flow being output through the CAL GAS outlets on the back of the instrument	0 cm ³ /min	5,000 cm ³ /min
REGULATOR PRESSURE	The gas pressure measured by the O ₃ generator pressure sensor	0 PSIG	105 PSIG
SAMPLE PRESSURE	The pressure of gas in the photometer absorption tube	0 "Hg	40 "Hg-In-A
SAMPLE FLOW	The gas flow rate through the photometer	0 cm ³ /min	1000 cc ³ /min
SAMPLE TEMP	The temperature of gas in the photometer absorption tube	0 °C	70 °C
PHOTO LAMP TEMP	The temperature of the photometer UV lamp	0 C°C	70 °C
O3 LAMP TEMP	The temperature of the O ₃ generator's UV lamp	0 mV	5000 mV
CHASSIS TEMP	The temperature inside the chassis (same as BOX TEMP)	0 °C	70 °C
O3 PHOTO CONC	The current concentration of O ₃ being measured by the photometer.	0 °C	1 ppm

Once a function is selected, the instrument not only begins to output a signal on the analog output, but also adds **TEST** to the list of Test Functions viewable via the Front Panel Display.

To activate the **TEST** Channel and select a function press:

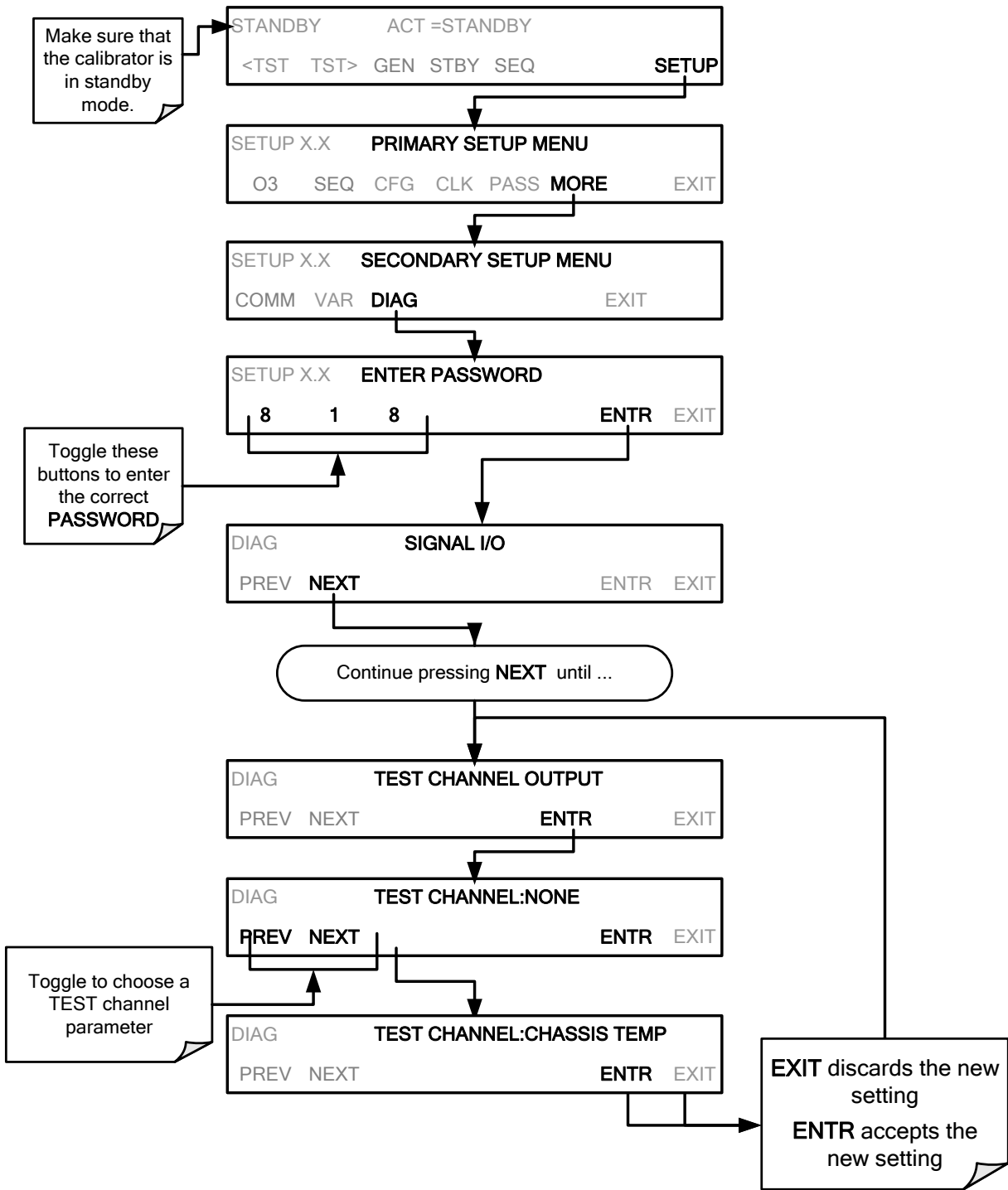

4.9.1.3. TEST Channel Voltage Range Configuration

In its standard configuration the analog outputs is set to output a 0 – 5 VDC signals. Several other output ranges are available (see Table 7-5). Each range has is usable from -5% to + 5% of the rated span.

Table 4-9: Analog Output Voltage Range Min/Max

RANGE SPAN	MINIMUM OUTPUT	MAXIMUM OUTPUT
0-100 mVDC	-5 mVDC	105 mVDC
0-1 VDC	-0.05 VDC	1.05 VDC
0-5 VDC	-0.25 VDC	5.25 VDC
0-10 VDC	-0.5 VDC	10.5 VDC

The default offset for all ranges is 0 VDC.

To change the output range, press,

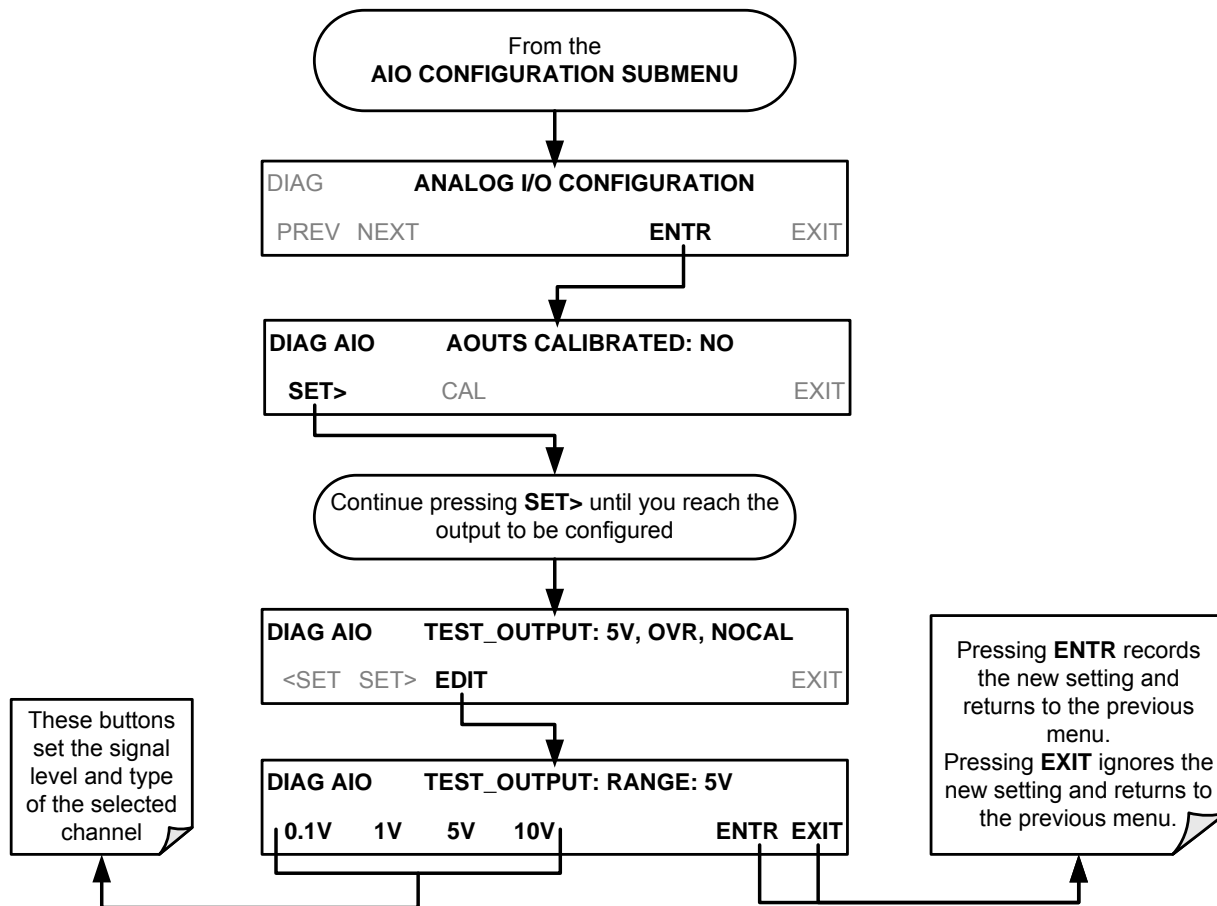

4.9.1.4. Turning the TEST Channel Over-Range Feature ON/OFF

In its default configuration a $\pm 5\%$ over-range is available on each of the **TEST CHANNEL** output. This over-range can be disabled if your recording device is sensitive to excess voltage or current.

To turn the over-range feature on or off, press:

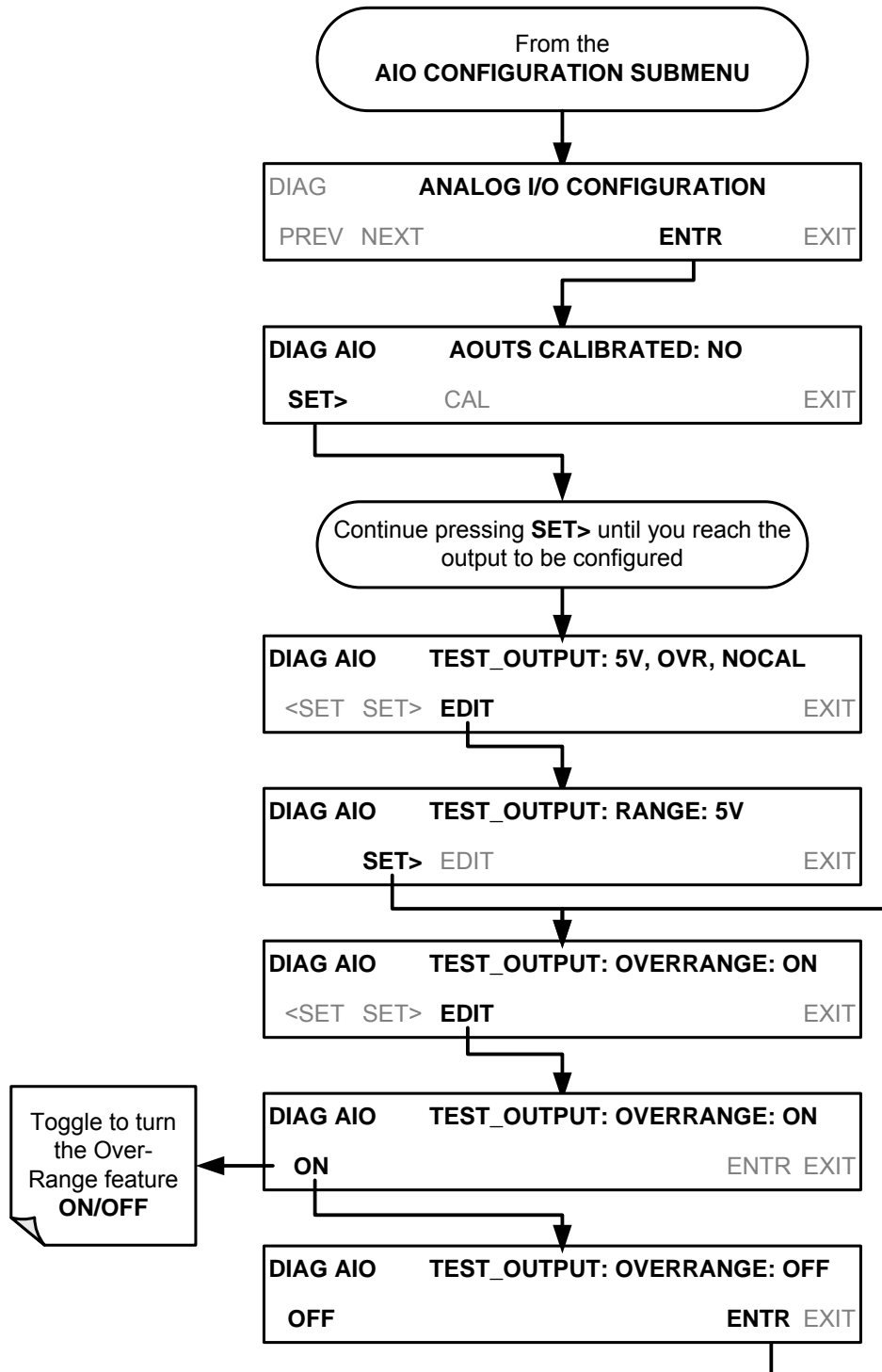

4.9.1.5. Adding a Recorder Offset to the TEST Channel

Some analog signal recorders require that the zero signal be significantly different from the baseline of the recorder in order to record slightly negative readings from noise around the zero point. This can be achieved by defining a zero offset, a small voltage (e.g., 10% of span).

To add a zero offset to a specific analog output channel, press:

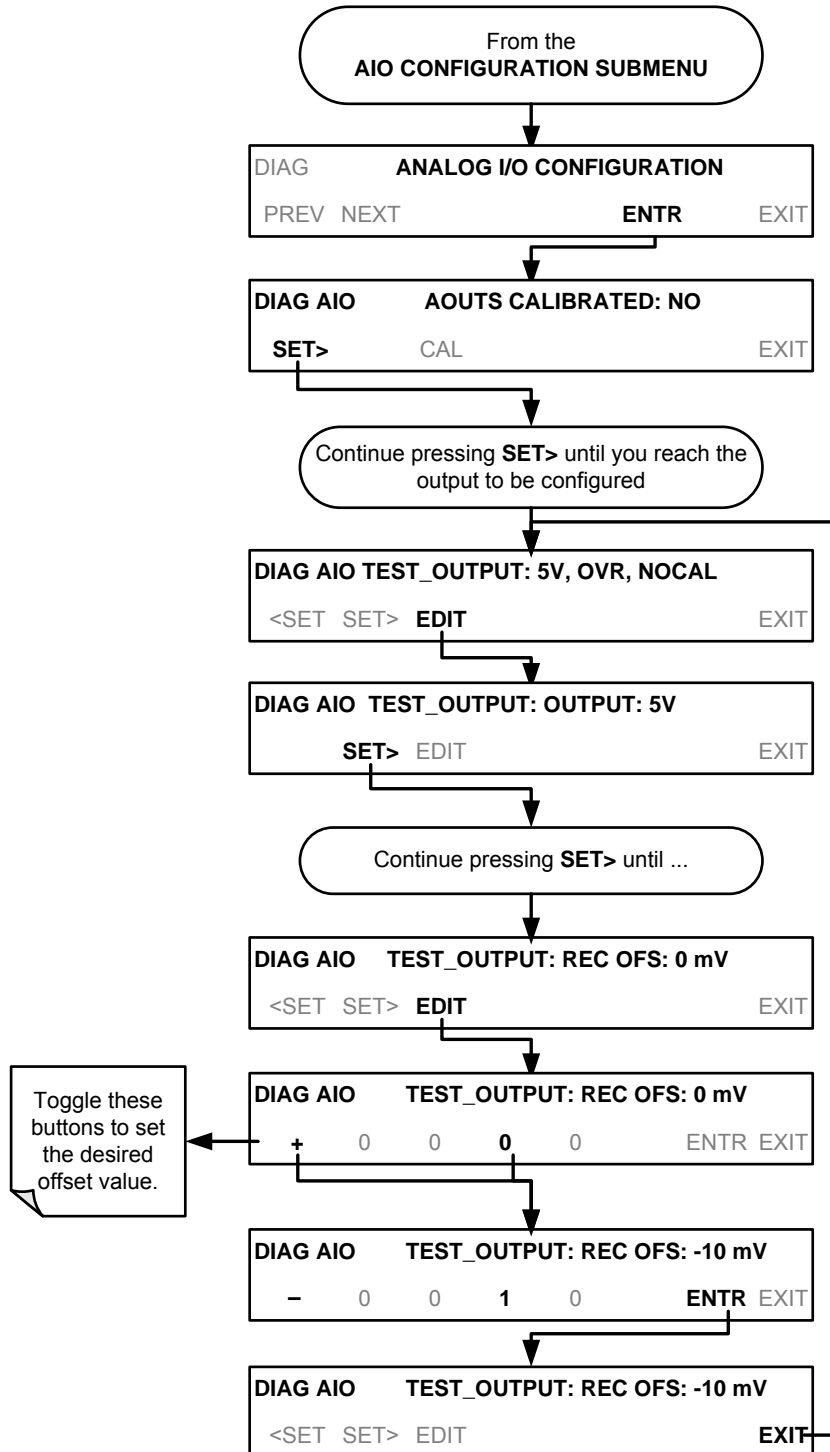

4.9.2. TEST CHANNEL CALIBRATION

TEST CHANNEL calibration needs to be carried out on first startup of the instrument (performed in the factory as part of the configuration process) or whenever re-calibration is required. The analog outputs can be calibrated automatically or adjusted manually. In its default mode, the instrument is configured for automatic calibration of all channels, which is useful for clearing any analog calibration warnings associated with channels that will **not** be used or connected to any input or recording device, e.g., datalogger.

During automatic calibration, the instrument tells the output circuitry to generate a zero mV signal and high-scale point signal (usually about 90% of chosen analog signal scale) then measures actual signal of the output. Any error at zero or high-scale is corrected with a slope and offset.

Manual calibration should be used for the 0.1V range or in cases where the outputs must be closely matched to the characteristics of the recording device. Manual calibration requires the AUTOCAL feature to be disabled.

Automatic calibration can be performed via the **AOUTS CALIBRATION** command, or by using the **CAL** button located inside **TEST_CHANNEL** submenu. By default, the instrument is configured so that calibration of **TEST CHANNEL** can be initiated with the **AOUTS CALIBRATION** command.

4.9.2.1. Enabling or Disabling the TEST CHANNEL Auto-Cal Feature

To enable or disable the Auto-Cal feature for the TEST CHANNEL, press.

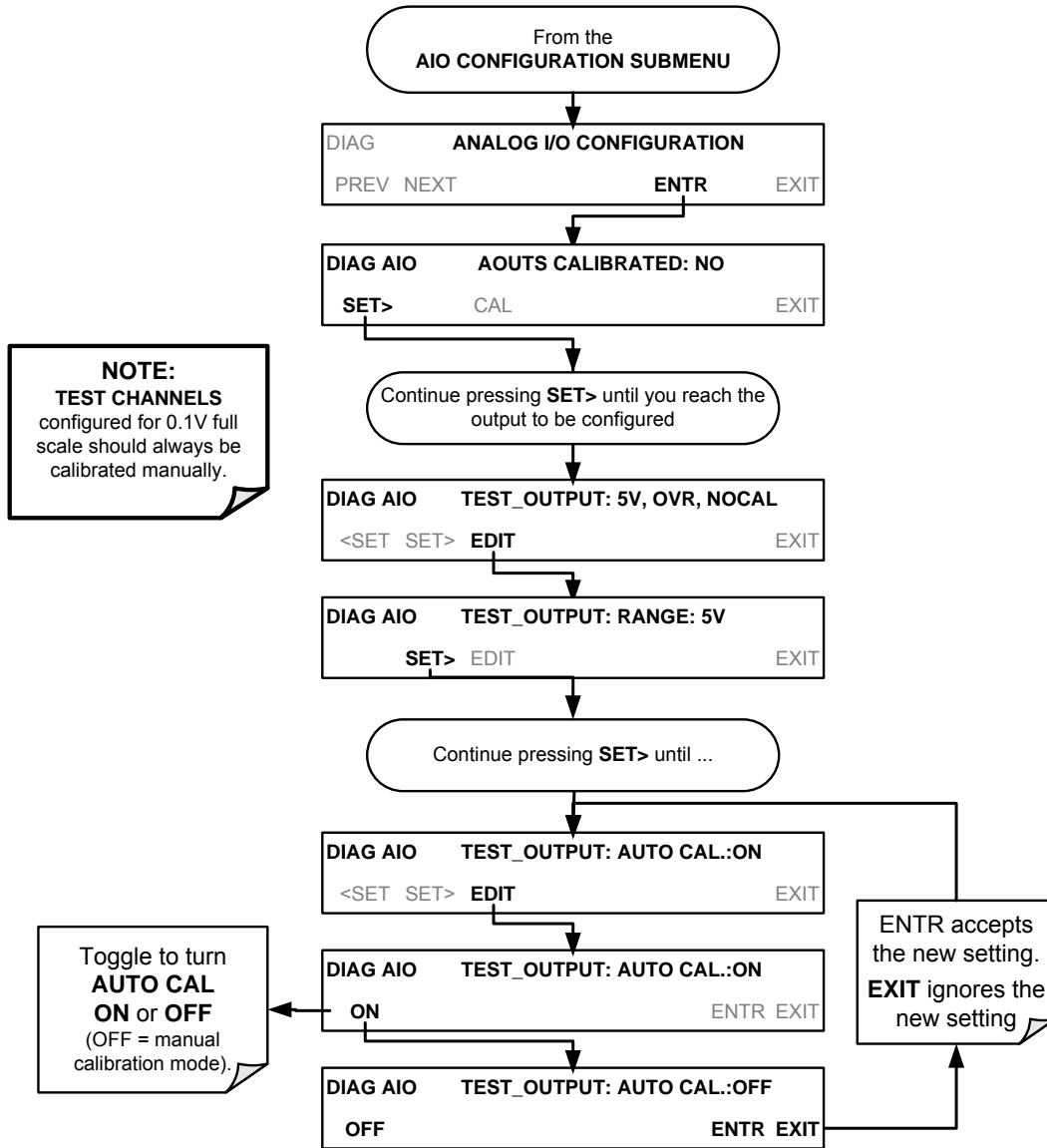

4.9.2.2. Automatic TEST Channel Calibration

To calibrate the outputs as a group with the **AOUTS CALIBRATION** command, press:

NOTE

Before performing this procedure, make sure that the **AUTO CAL** feature is turned **OFF** for **CONC_OUT_1** and **CONC_OUT_2**,
 Make sure that the **AUTO CAL** feature is turned **ON** for the **TEST CHANNEL** (See Section 4.9.2.1)

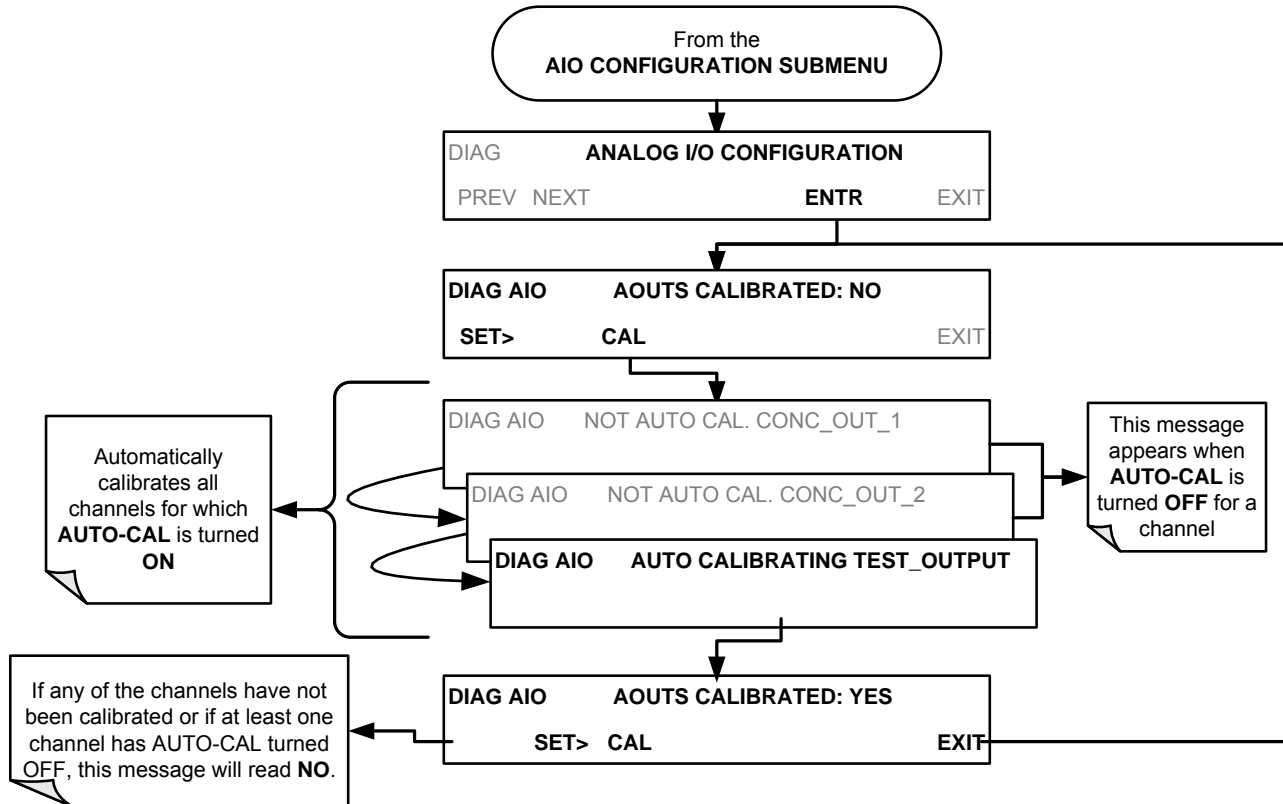

NOTE:

Manual calibration should be used for the 0.1V range or in cases where the outputs must be closely matched to the characteristics of the recording device.

To initiate an automatic calibration from inside the **TEST CHANNEL** submenu, press:

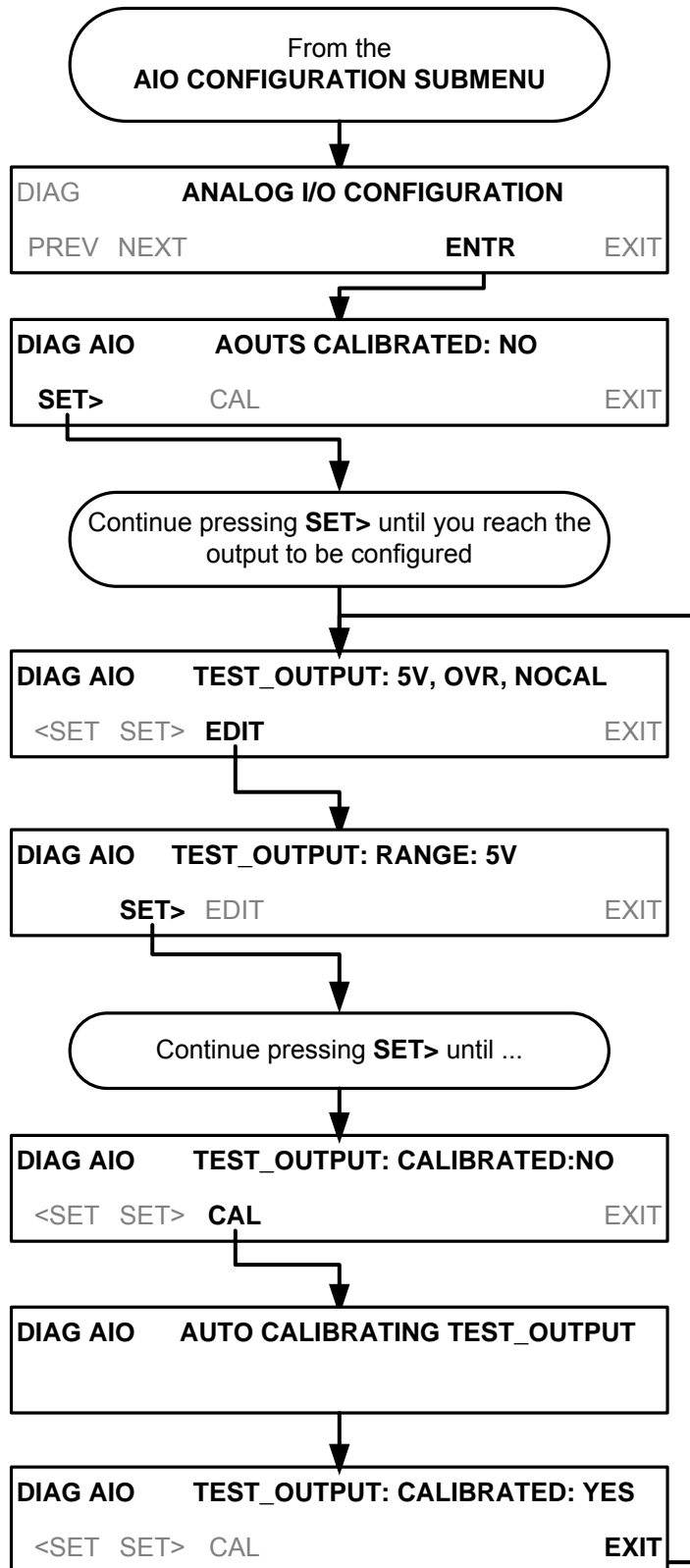

4.9.2.3. Manual Calibration of the TEST Channel Configured for Voltage Ranges

For highest accuracy, the voltages of the analog outputs can be manually calibrated.

NOTE:

The menu for manually adjusting the analog output signal level will only appear if the AUTO-CAL feature is turned off for the channel being adjusted (see Section 4.9.2.1)

Calibration is performed with a voltmeter connected across the output terminals (See Figure 4-2) and by changing the actual output signal level using the front panel menu buttons in 100, 10 or 1 count increments.

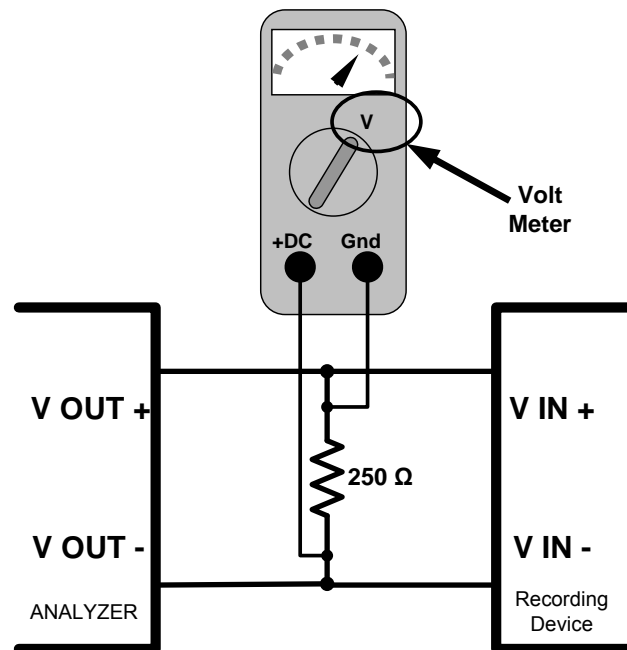
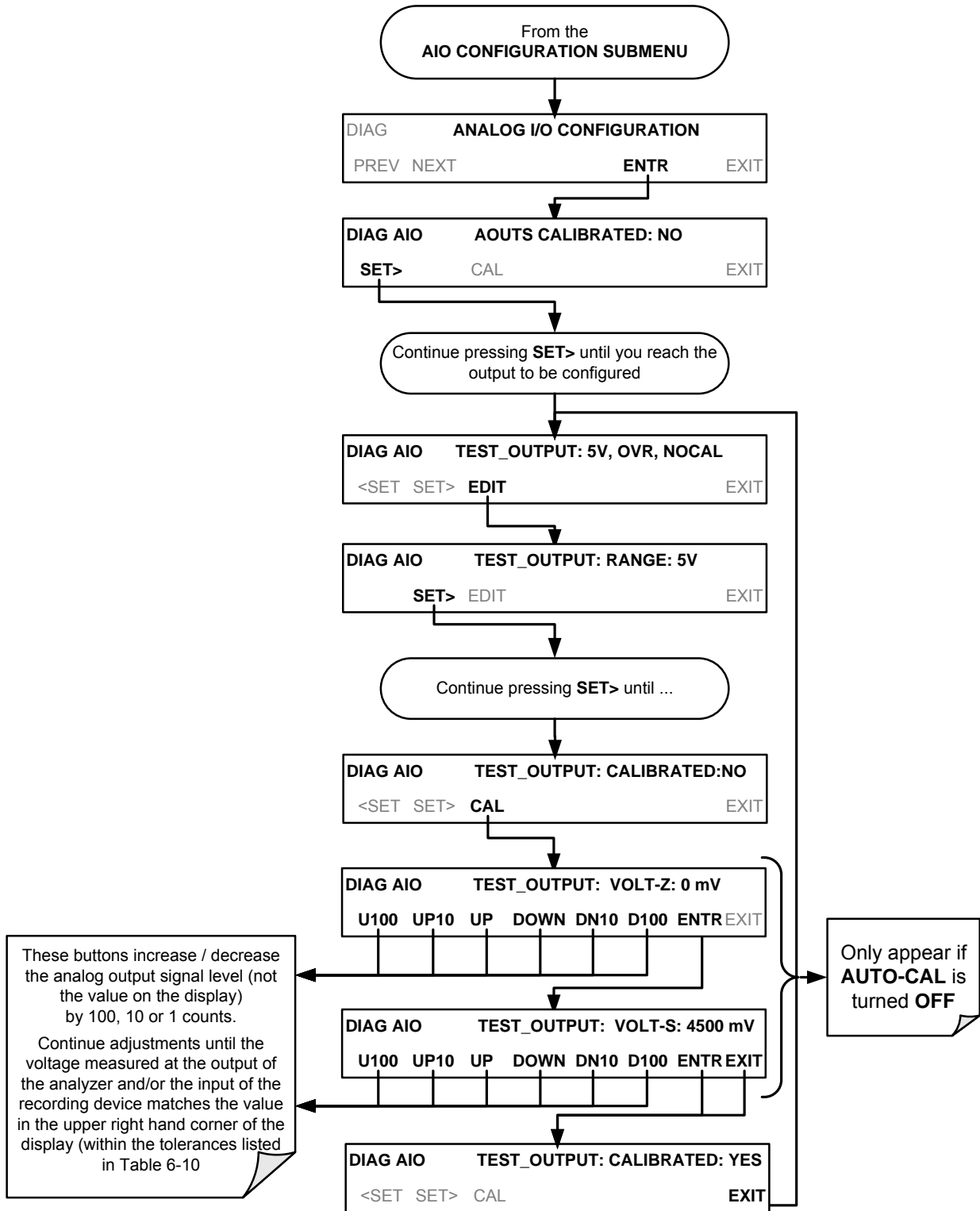

Figure 4-3: Setup for Calibrating the TEST CHANNEL

Table 4-10: Voltage Tolerances for the TEST CHANNEL Calibration

FULL SCALE	ZERO TOLERANCE	SPAN VOLTAGE	SPAN TOLERANCE	MINIMUM ADJUSTMENT (1 count)
0.1 VDC	±0.0005V	90 mV	±0.001V	0.02 mV
1 VDC	±0.001V	900 mV	±0.001V	0.24 mV
5 VDC	±0.002V	4500 mV	±0.003V	1.22 mV
10 VDC	±0.004V	4500 mV	±0.006V	2.44 mV

To adjust the signal levels of an analog output channel manually, press:



4.9.3. AIN CALIBRATION

This is the sub-menu to calibrate the instrument's A-to-D conversion circuitry. This calibration should only be necessary after major repair such as a replacement of CPU, motherboard or power supplies.

To perform an **AIN CALIBRATION**, press:

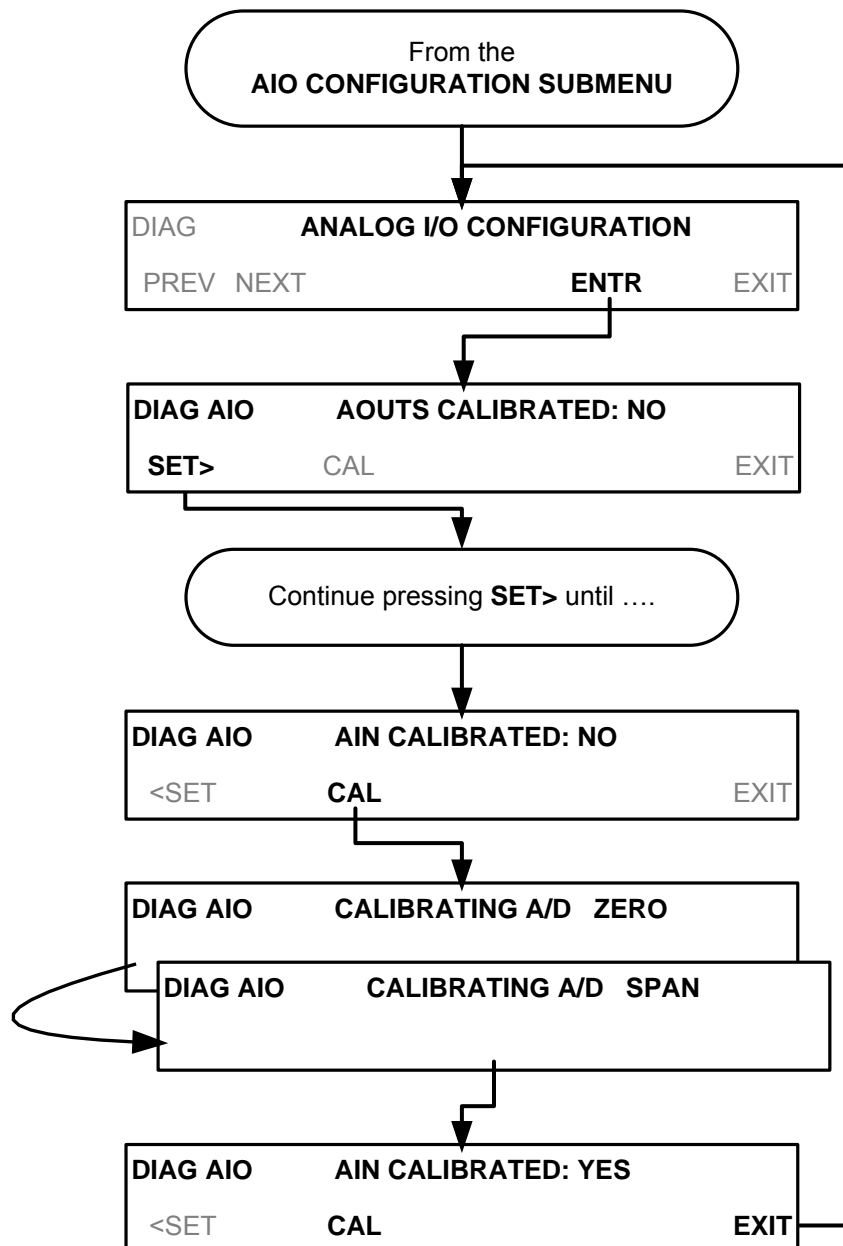

4.10. SETUP > MORE > VARS: INTERNAL VARIABLES (VARS)

The T703/T703U has several user-adjustable software variables, which define certain operational parameters. The default values can be manually redefined using the VARS menu.

The VARS are listed in the following table as well as in Appendix A.

Table 4-11: Variable Names (VARS)

NO.	VARIABLE	DESCRIPTION	ALLOWED VALUES	DEFAULT VALUES
0	PHOTO_LAMP ^{1,2}	Sets the photometer lamp temperature set point and warning limits.	0°C and 100°C	58°C Warning limits 56°C - 61°C
1	O3_GEN LAMP ^{1,2}	Sets the O ₃ generator lamp temperature set point and warning limits.	0°C and 100°C	48°C Warning limits 43°C - 53°C
2	O3_CONC_RANGE	Set the upper span point of the O ₃ concentration range for TEST CHANNEL analog signal O3_PHOTO_CONC.	0.1–20000 ppb	500 ppb
3	O3_PHOTO_BENCH_ONLY ²	O ₃ bench control flag. • ON turns on the photometer pump and switches measure/reference valve only when the O ₃ mode is set for BNCH (See Section 3.4.5).	ON/OFF	OFF
4	ZA_PUMP_ENAB ²	Internal zero air pump control. ON turns on internal zero air pump when generating ozone.	ON/OFF	ON
5	STD_TEMP ¹	Sets the standard Temperature used in calculating O ₃ flow rates and concentrations.	0°C and 100°C	25°C
6	STD PRESS ¹	Sets the standard pressure used in calculating O ₃ flow rates and concentrations.	29.92 in-Hg-A	15.00 – 50 .00 in-Hg-A
7	CLOCK_ADJ	Adjusts the speed of the instrument's clock. Choose the + sign if the clock is too slow, choose the - sign if the clock is too fast (See Section 4.7.2).	-60 to +60 s/day Default=0	0
8	SERVICE_CLEAR	Restarts interval timer since instrument's last service, by setting the value to ON. (The system then resets it to default OFF).	ON/OFF	OFF
9	TIME_SINCE_SVC	Time since last service (in hours).	0-500000	0
10	SVC_INTERVAL	Sets the interval between service reminders (in hours).	0–100000	0
<p>¹ DO NOT ADJUST OR CHANGE these values unless instructed to by Teledyne API's Technical Support personnel.</p> <p>² Only available in calibrators with O₃ photometer and generator options installed.</p>				

NOTE:

There is a 2-second latency period between when a VARS value is changed and the new value is stored into the instrument's memory. **DO NOT** turn the instrument off during this period or the new setting will be lost.

To access and navigate the VARS menu, use the following menu button sequence:

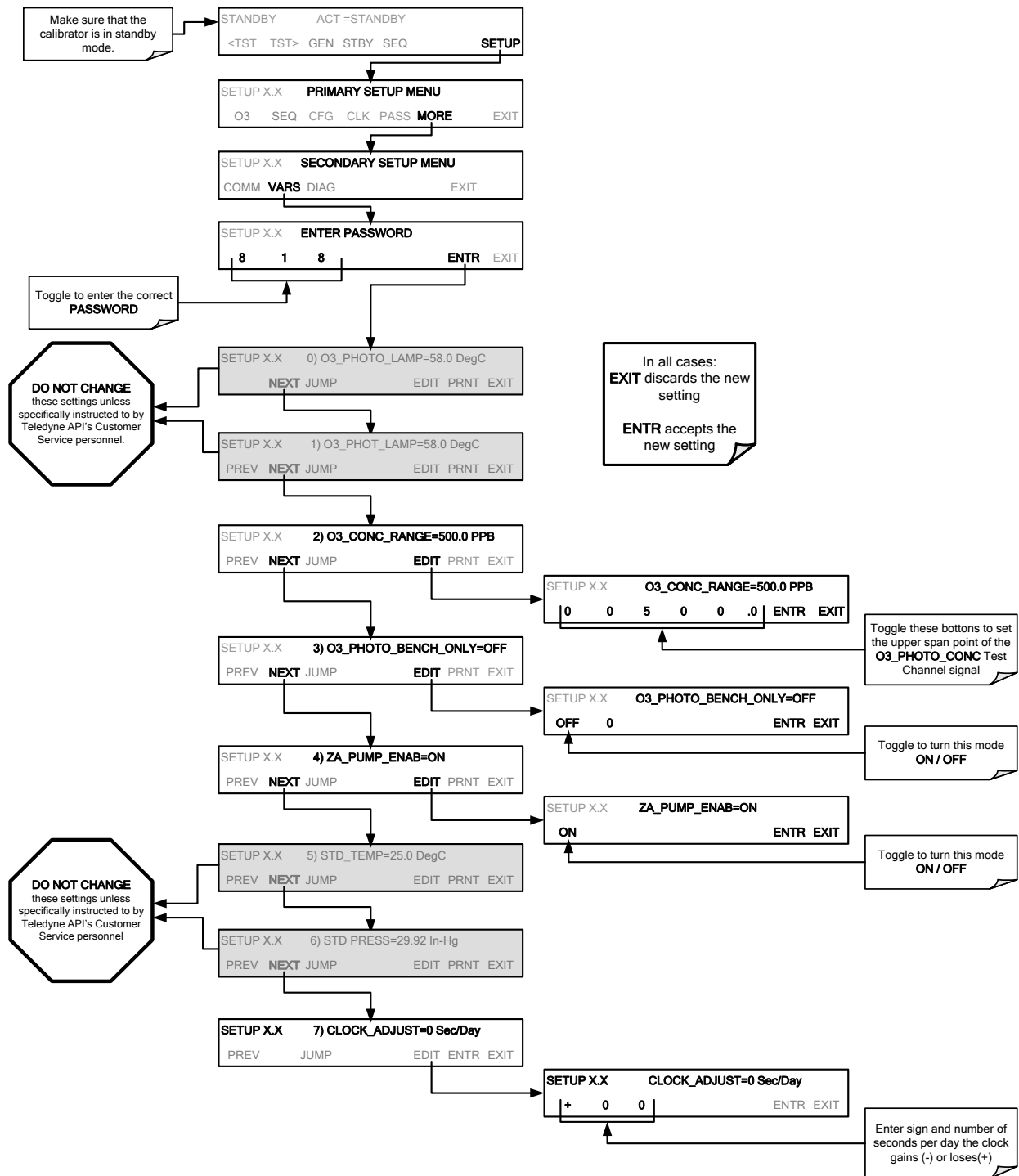

4.11. OPERATING THE CALIBRATOR AS AN O₃ PHOTOMETER

The T703/T703U can easily be configured to measure an external source of ozone.

4.11.1. SET UP FOR OPERATION AS AN O₃ PHOTOMETER

To convert the T703/T703U from an O₃ calibrator to and O₃ photometer:

1. Remove the two loop-back tubing assemblies on the rear panel connected to the 'PHOTO IN' and 'PHOTO ZERO IN' fittings.
2. Connect the ozone source to be measured to the 'PHOTO IN' fitting.
 - This gas must be supplied at atmospheric pressure.
3. Connect a reference gas (Zero Air) for the photometer to the 'PHOTO ZERO IN' fitting.
 - This gas must be supplied at atmospheric pressure. To avoid interference effects, the reference gas should be from the same source than is being used to feed the ozone generator that is being assayed.

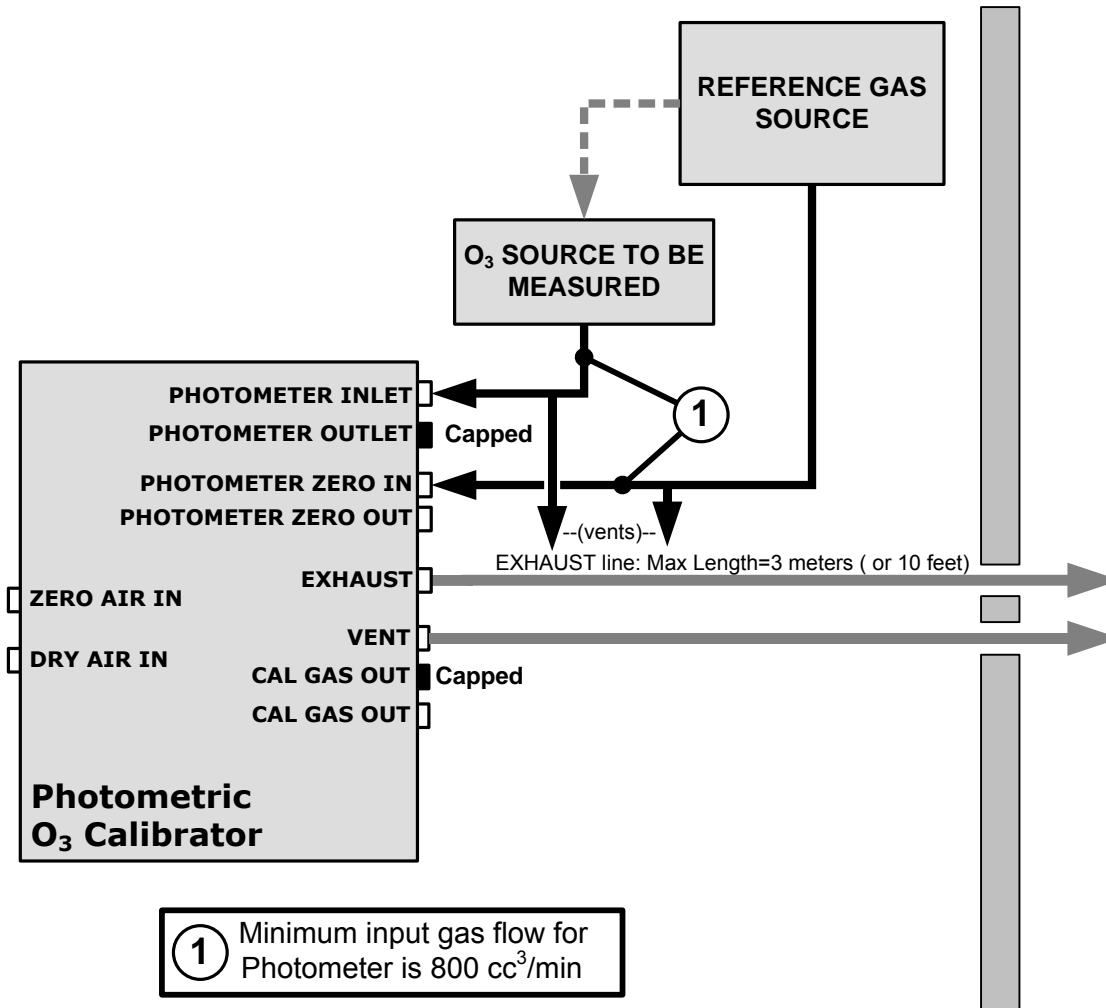
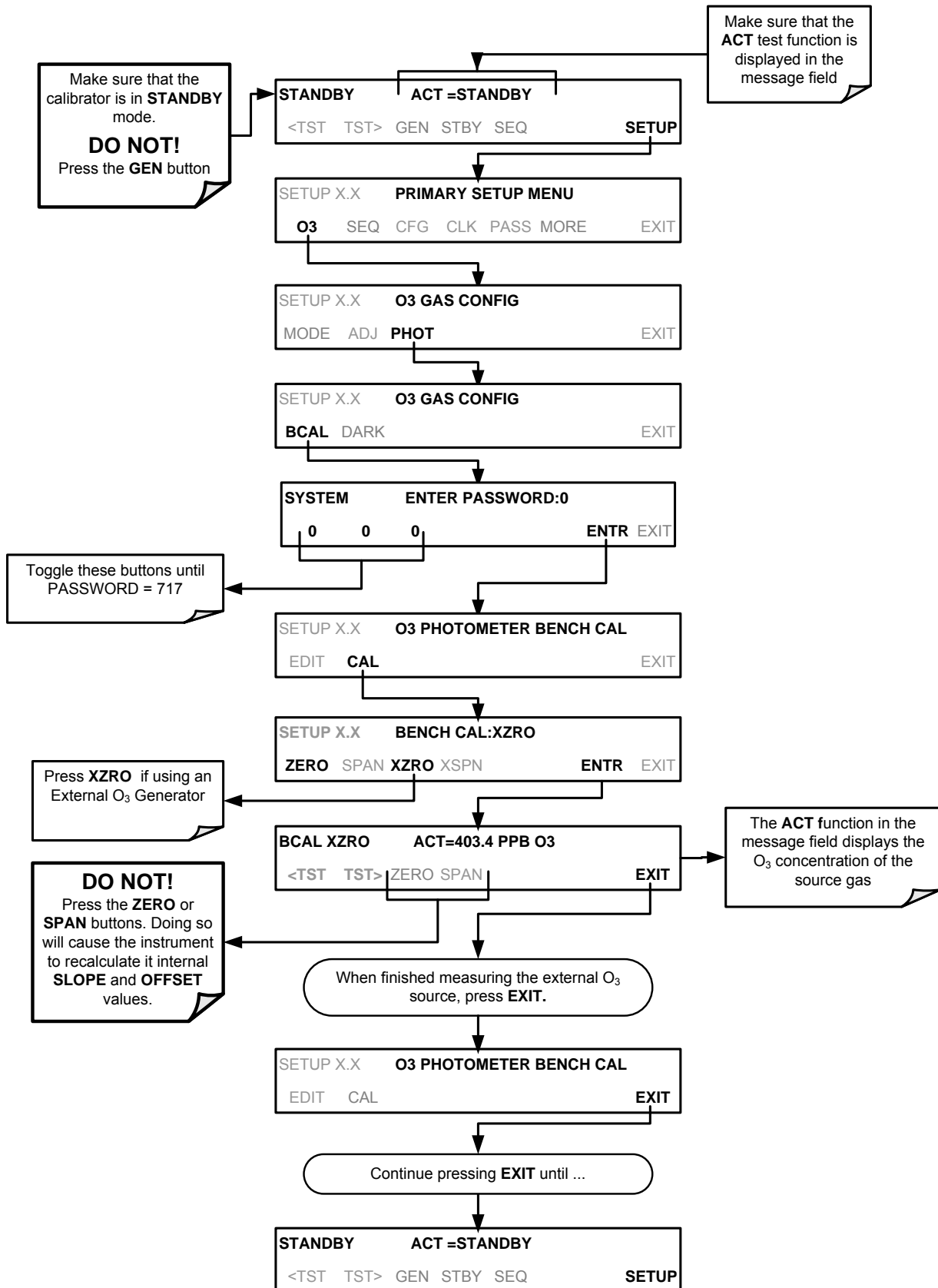

Figure 4-4: Set up to Measure an External O₃ Source

To use the T703/T703U as a photometer, press:



4.12. SETUP > LVL: SETTING UP AND USING LEADS (DASIBI) OPERATING LEVELS

4.12.1. GENERAL INFORMATION ABOUT LEADS LEVELS

The T703 calibrator can be equipped with a version of firmware that includes support for LEADS, a data collection and analysis system specifically designed for handling meteorological and environmental data, particularly when there is a need to integrate data and control instrumentation from several different manufacturers. When a T703 calibrator is equipped with the optional LEADS software used in conjunction with data loggers located in a central data analysis facility, it is possible to collect and buffer data between the various calibrators, analyzers and metrological equipment remotely located at an air monitoring station.

Because LEADS was originally developed for use with TNRCC using Dasibi 5008 calibrators, the LEADS version of the T703 includes support for Dasibi “Dot” serial data commands and operational “LEVELS”.

NOTE

For more information on the LEADS system, please go to <http://www.meteostar.com/>.

4.12.2. DOT COMMANDS

The Dasibi “Dot” commands form a text-based (ASCII) data protocol that is transmitted between a control computer (XENO data logger in this case) and a calibrator or ambient gas analyzer over an RS-232 connection. The details of the protocol are beyond the scope of this document, but in its simplest form the protocol is based on a two or three digit integer preceded by a control-A and a period (.) and then followed by a “!” and a two digit checksum.

EXAMPLE:

^A.xxx!nn

For further information on dot commands, please contact TAPI Technical Support.

A T703 equipped with LEADS software can be simultaneously operated over the same COM port using standard Teledyne API’s serial data commands and is compatible with APICOM versions 3.7.3 and later which include an added feature that allows a user to edit, upload and download level tables.

4.12.3. LEVELS

A **LEVEL** is a combination of several parameters:

- An ID number for the LEVEL
- An action, (e.g. GENERATE, STANDBY)
 - A target concentration value
 - An output flow rate (if applicable)
 - Configuration for one or both of two status output blocks.

Up to twenty levels can be defined and used with the T703 using a range of ID numbers from 0-98. Level 99 is reserved for standby. Are not time based and do not include characteristics such as start time or duration, therefore a single LEVEL can not switch between different concentration levels and flow rates. Separate flow and concentration outputs must be programmed into separate LEVELs which are then individually started and stopped either by an operator at the calibrator's front panel or through a serial data operation over the RS-232 or Ethernet ports.

4.12.4. ACTIVATING AN EXISTING LEVEL

To activate an existing defined LEVEL, press:

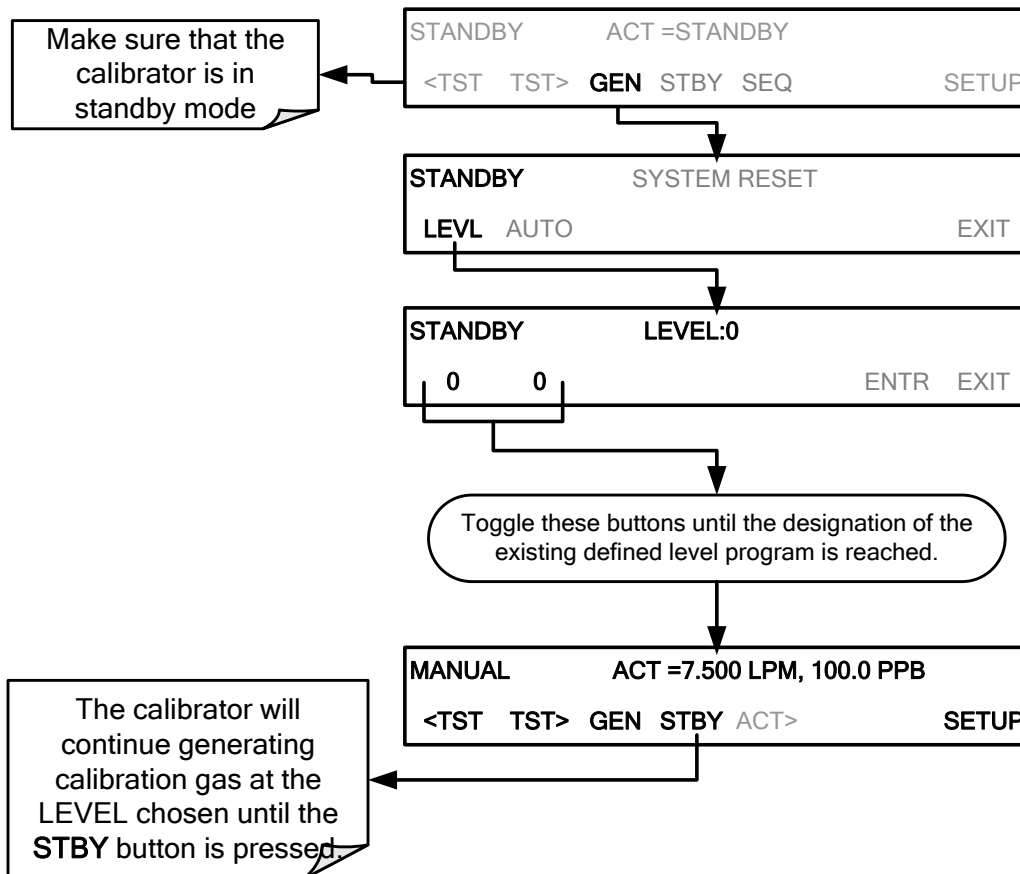

4.12.5. PROGRAMMING NEW LEVELS

To begin programming a new **LEVEL** find the **LVL** submenu by pressing:

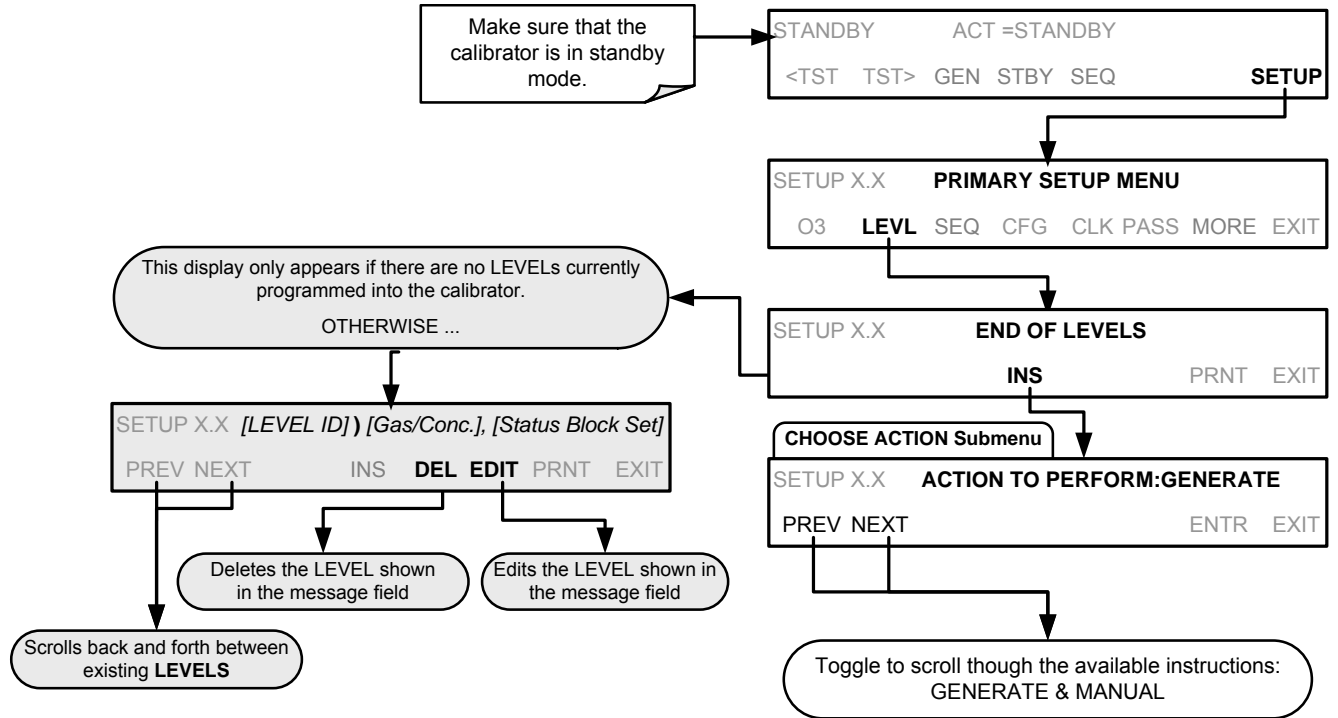

4.12.5.1. Creating a Generate LEVEL

To create a **LEVEL** using the **AUTO** generation function, press:

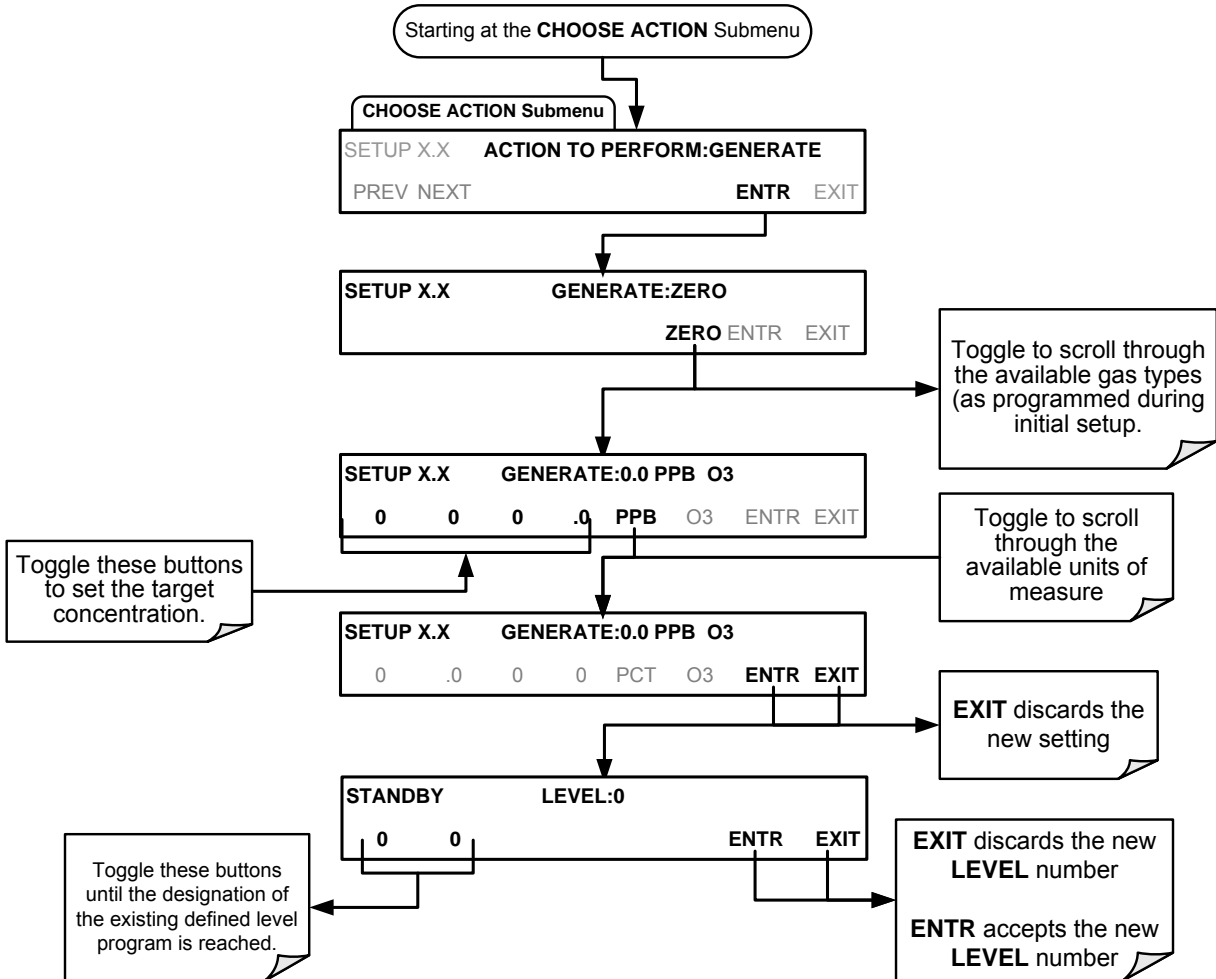

4.12.5.2. Editing or Deleting a LEVEL

To edit or delete an existing **LEVEL**, press:

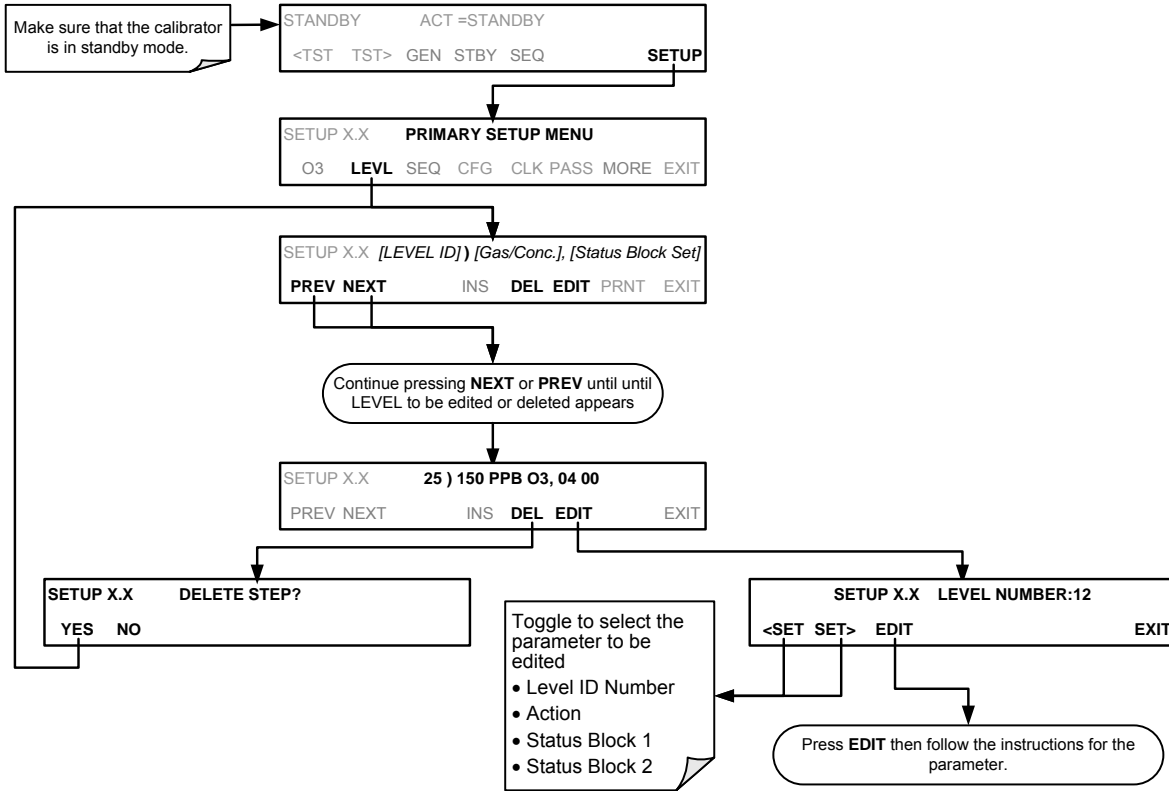

Levels are displayed according to the following Format:

- LEVEL ID: Any number between 0 and 99. This will be the number used to select the level when activating / deactivating it, or when editing or deleting it.
- Gas Conc: The concentration setting, in ppb, for the O₃ generator to produce.
- Status Block Setting: This will be displayed as two pairs of 1-digit numbers.
 - The First pair corresponds to Status Block 1.
 - The Second pair corresponds to Status Block 2.

In each case:

- The left digit will be a number between 1 and 4 representing the binary setting of bits 1 through 4 and;
- The right digit will be a number between 1 and 4 representing the binary setting of bits 5 through 8.

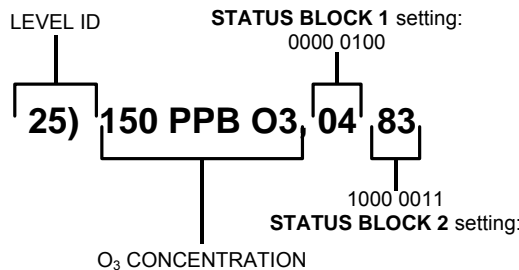

Figure 4-5: LEADS Level Display Format

4.12.6. CONFIGURING LEVEL STATUS BLOCKS

There are two **STATUS BLOCKS** associated with **LEADS LEVELS**.

- **BLOCK 1:** This block corresponds to the physical CONTROL OUTPUT connections located on the back panel of the T703 (see Figure 3-4, Figure 3-12 and Section 3.2.5).
- **BLOCK 2:** The second status block does not correspond to any physical output but is used to communicate status over the serial data port

To configure the either of the **STATUS BLOCKS**, press:

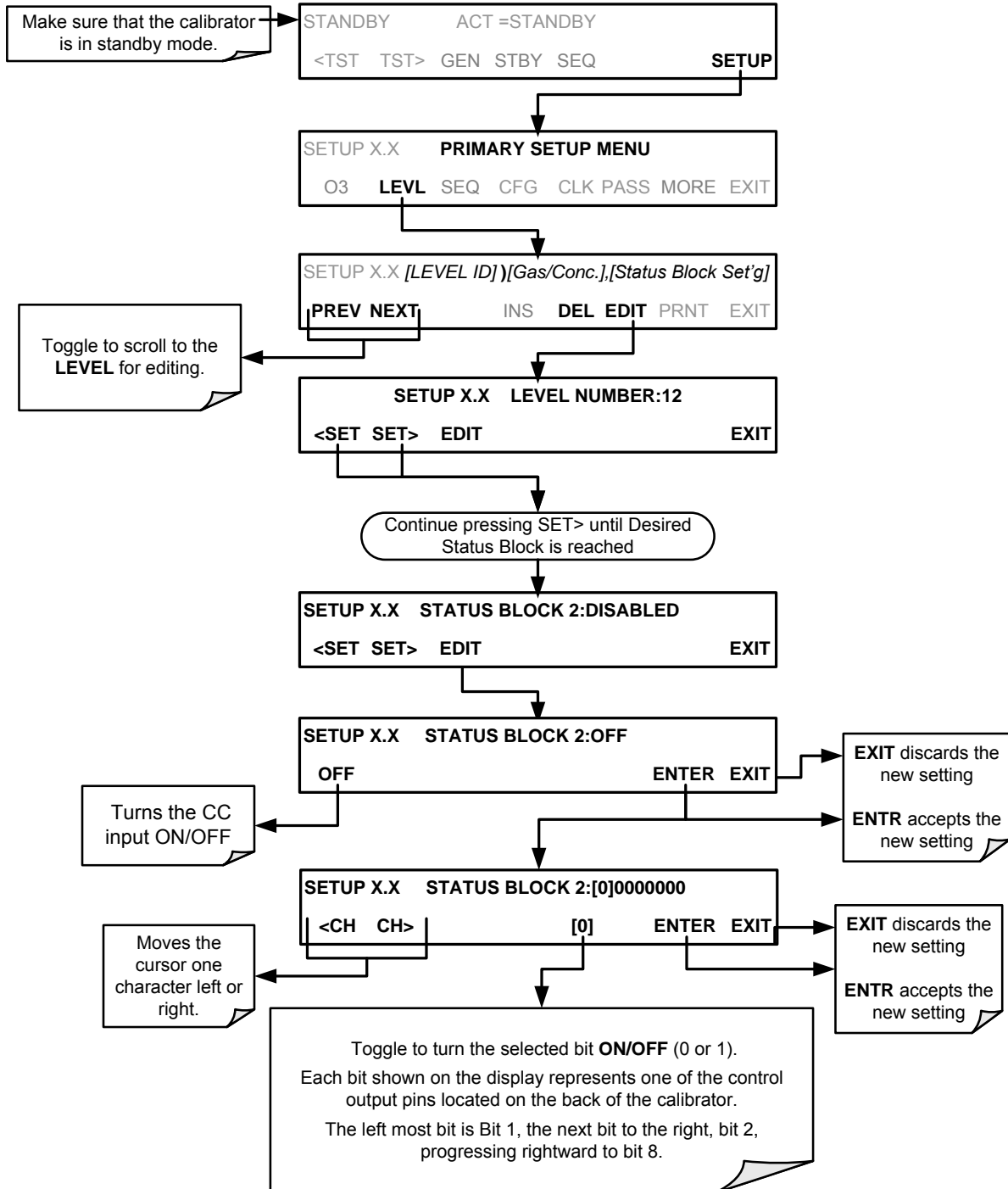

This page intentionally left blank.

5. COMMUNICATIONS

5.1. USING THE ANALYSER'S COMMUNICATION PORTS

The T703 is equipped with two serial communication ports, labeled **RS232** (male DB-9 connector) and **COM2** (female DB-9 connector), a USB com port and an Ethernet port located on the rear panel.

The **RS232** (COM1) and **COM2** ports operate similarly and give the user the ability to communicate with, issue commands to, and receive data from the calibrator through an external computer system or terminal.

- The RS-232 port (COM1) can also be configured to operate in standard or RS-232 multidrop mode (Section 5.3).
- The COM2 port is configured for standard RS-232 operation by default, but can be configured for half-duplex RS-485 communication. (Contact the factory for RS-485 communication configuration).
- The COM2 port is disabled for all but Multidrop communications when the unit is configured for USB communications.

The Ethernet connector allows the instrument to be connected to a network running TCP/IP or to the public Internet if access is available. The network must have routers capable of operating at 10Base-T or 100Base-T. DHCP is enabled by default (Section 5.6.1). This configuration is useful for quickly getting an instrument up and running on a network. However, for permanent Ethernet connections, a static IP address should be used (Section 5.6.1.1).

5.1.1. RS-232 DTE AND DCE COMMUNICATION

RS-232 was developed for allowing communications between data terminal equipment (DTE) and data communication equipment (DCE). Basic data terminals always fall into the DTE category whereas modems are always considered DCE devices.

Electronically, the difference between the DCE & DTE is the pin assignment of the Data Receive and Data Transmit functions.

- DTE devices receive data on pin 2 and transmit data on pin 3.
- DCE devices receive data on pin 3 and transmit data on pin 2.

A switch located below the serial ports on the rear panel allows the user to switch between DTE (for use with data terminals) or DCE (for use with modems). Since computers can be either DTE or DCE, check your computer to determine which mode to use. Edit the Instrument and Gateway IP addresses and Subnet Mask to the desired settings. Then, from the computer, enter the same information through an application such as HyperTerminal.

5.1.2. SERIAL COM PORT DEFAULT SETTINGS AND CONNECTOR PIN ASSIGNMENTS

Received from the factory, the calibrator is set up to emulate an RS-232 DCE device.

- **RS-232 (COM1):** RS-232 (fixed), DB-9 male connector.
 - **Baud rate:** 115200 bits per second (baud).
 - **Data Bits:** 8 data bits with 1 stop bit.
 - **Parity:** None.
- **COM2:** RS-232 (configurable to RS 485), DB-9 female connector.
 - **Baud rate:** 19200 bits per second (baud).
 - **Data Bits:** 8 data bits with 1 stop bit.
 - **Parity:** None.

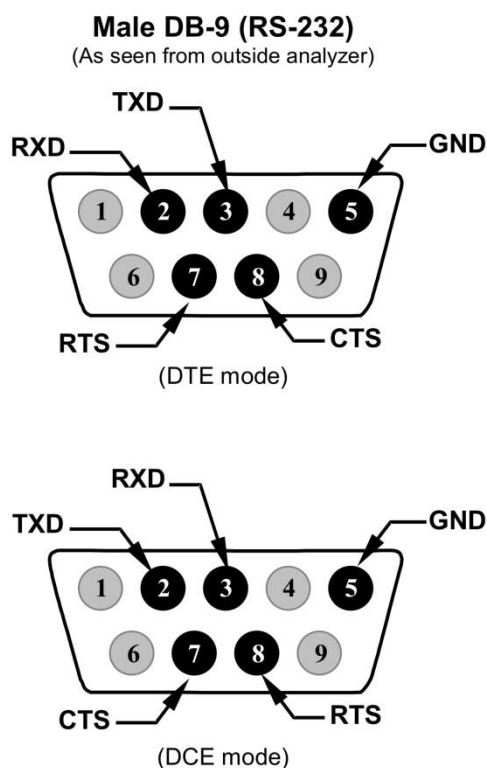

Figure 5-1: Default Pin Assignments for Rear Panel COM Port connectors (RS-232 DCE & DTE)

The signals from these two connectors are routed from the motherboard via a wiring harness to two 10-pin connectors on the CPU card, J11 and J12.

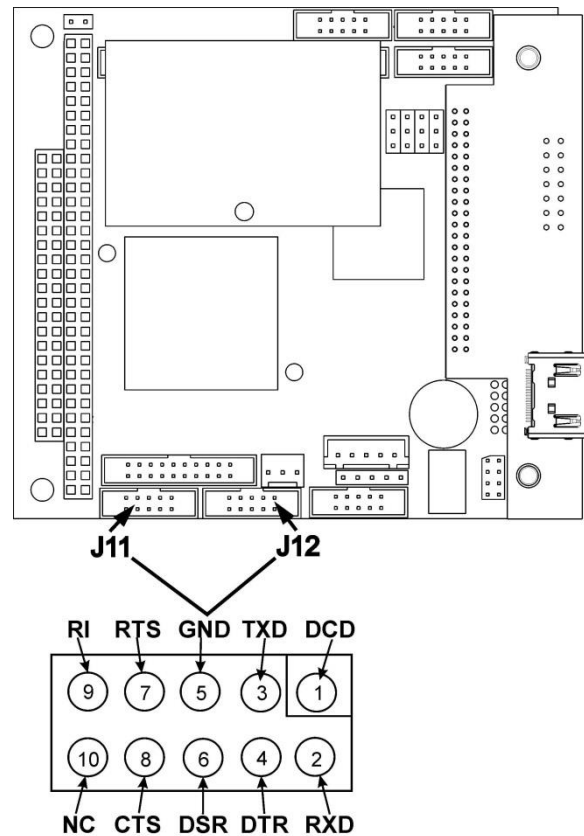

Figure 5-2: CPU COM1 & COM2 Connector Pin-Outs for RS-232 Mode

Teledyne API offers two mating cables, one of which should be applicable for your use.

- Part number WR000077, a DB-9 female to DB-9 female cable, 6 feet long. Allows connection of the serial ports of most personal computers. Also available as Option 60 (see Section 1.2).
- Part number WR000024, a DB-9 female to DB-25 male cable. Allows connection to the most common styles of modems (e.g. Hayes-compatible) and code activated switches.

Both cables are configured with straight-through wiring and should require no additional adapters.

NOTE

Cables that appear to be compatible because of matching connectors may incorporate internal wiring that makes the link inoperable. Check cables acquired from sources other than Teledyne API for pin assignments before using.

To assist in properly connecting the serial ports to either a computer or a modem, there are activity indicators just above the RS-232 port. Once a cable is connected between the calibrator and a computer or modem, both the red and green LEDs should be on.

If the lights are not lit, use the slide switch on the rear panel to switch between DTE and DCE modes

If both LEDs are still not illuminated, make sure the cable properly constructed.

5.1.3. COM PORT BAUD RATE

To select the baud rate of either one of the COM Ports, press:

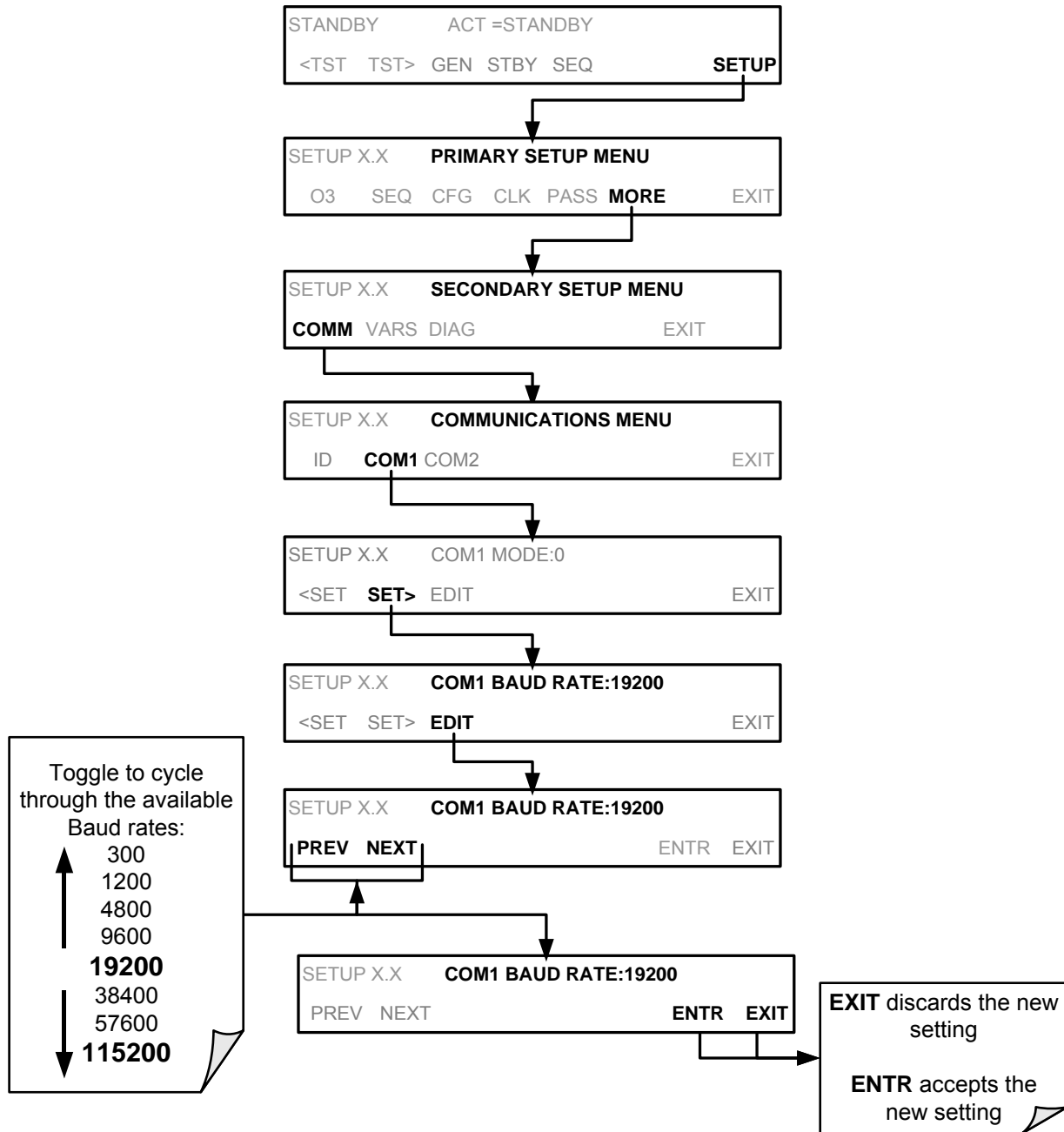

5.1.4. COM PORT COMMUNICATION MODES

Each of the calibrator’s serial ports can be configured to operate in a number of different modes, listed in Table 7-1. As modes are selected, the calibrator sums the Mode ID numbers and displays this combined number on the front panel display. For example, if quiet mode (01), computer mode (02) and Multi-Drop-

enabled mode (32) are selected, the Calibrator would display a combined **MODE ID** of 35.

Table 5-1: COM Port Communication Modes

MODE¹	ID	DESCRIPTION
QUIET	1	Quiet mode suppresses any feedback from the calibrator (such as warning messages) to the remote device and is typically used when the port is communicating with a computer program where such intermittent messages might cause communication problems. Such feedback is still available but a command must be issued to receive them.
COMPUTER	2	Computer mode inhibits echoing of typed characters and is used when the port is communicating with a computer operated control program.
SECURITY	4	When enabled, the serial port requires a password before it will respond. The only command that is active is the help screen (? CR).
E, 7, 1	2048	When turned on this mode switches the COM port settings from No parity; 8 data bits; 1 stop bit to Even parity; 7 data bits; 1 stop bit
RS-485	1024	Configures the COM2 Port for RS-485 communication. RS-485 mode has precedence over multidrop mode if both are enabled.
MULTIDROP PROTOCOL	32	Multidrop protocol allows a multi-instrument configuration on a single communications channel. Multidrop requires the use of instrument IDs.
ENABLE MODEM	64	Enables to send a modem initialization string at power-up. Asserts certain lines in the RS-232 port to enable the modem to communicate.
ERROR CHECKING²	128	Fixes certain types of parity errors at certain Hessen protocol installations.
XON/XOFF HANDSHAKE²	256	Disables XON/XOFF data flow control also known as software handshaking.
HARDWARE HANDSHAKE	8	Enables CTS/RTS style hardwired transmission handshaking. This style of data transmission handshaking is commonly used with modems or terminal emulation protocols as well as by Teledyne Instrument's APICOM software.
HARDWARE FIFO²	512	Disables the HARDWARE FIFO (First In – First Out), When FIFO is enabled it improves data transfer rate for that COM port.
COMMAND PROMPT	4096	Enables a command prompt when in terminal mode.
¹ Modes are listed in the order in which they appear in the SETUP > MORE > COMM > COM[1 OR 2] > MODE menu ² The default setting for this feature is ON . Do not disable unless instructed to by Teledyne API's Technical Support personnel.		

Note

Communication Modes for each COM port must be configured independently.

Press the following menu buttons to select communication modes for a one of the COM Ports, such as the following example where **RS-485** mode is enabled:

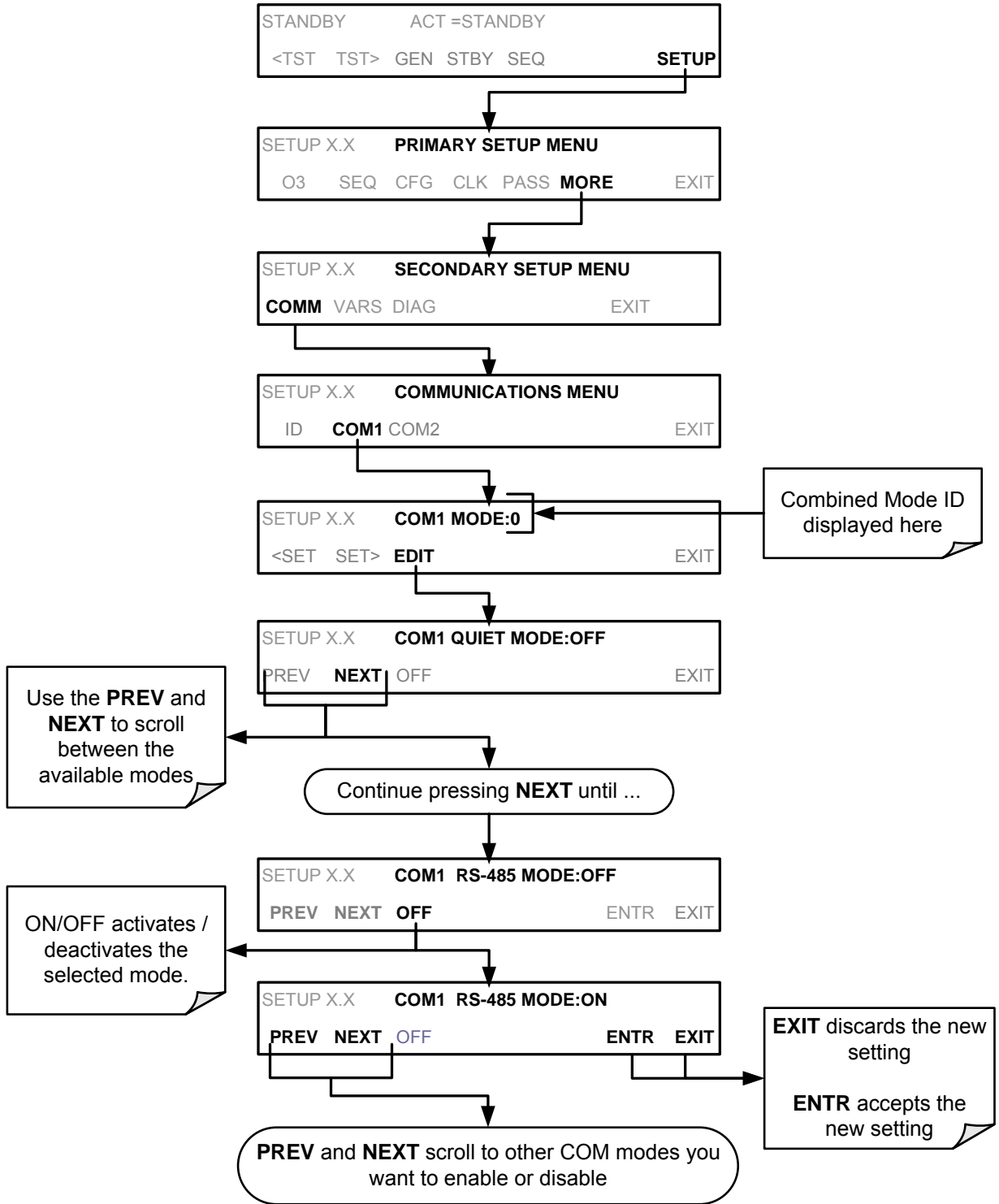

5.1.5. COM PORT TESTING

The serial ports can be tested for correct connection and output in the **COM** menu. This test sends a string of 256 'w' characters to the selected COM port. While the test is running, the red LED on the rear panel of the calibrator should flicker.

To initiate the test press the following key sequence.

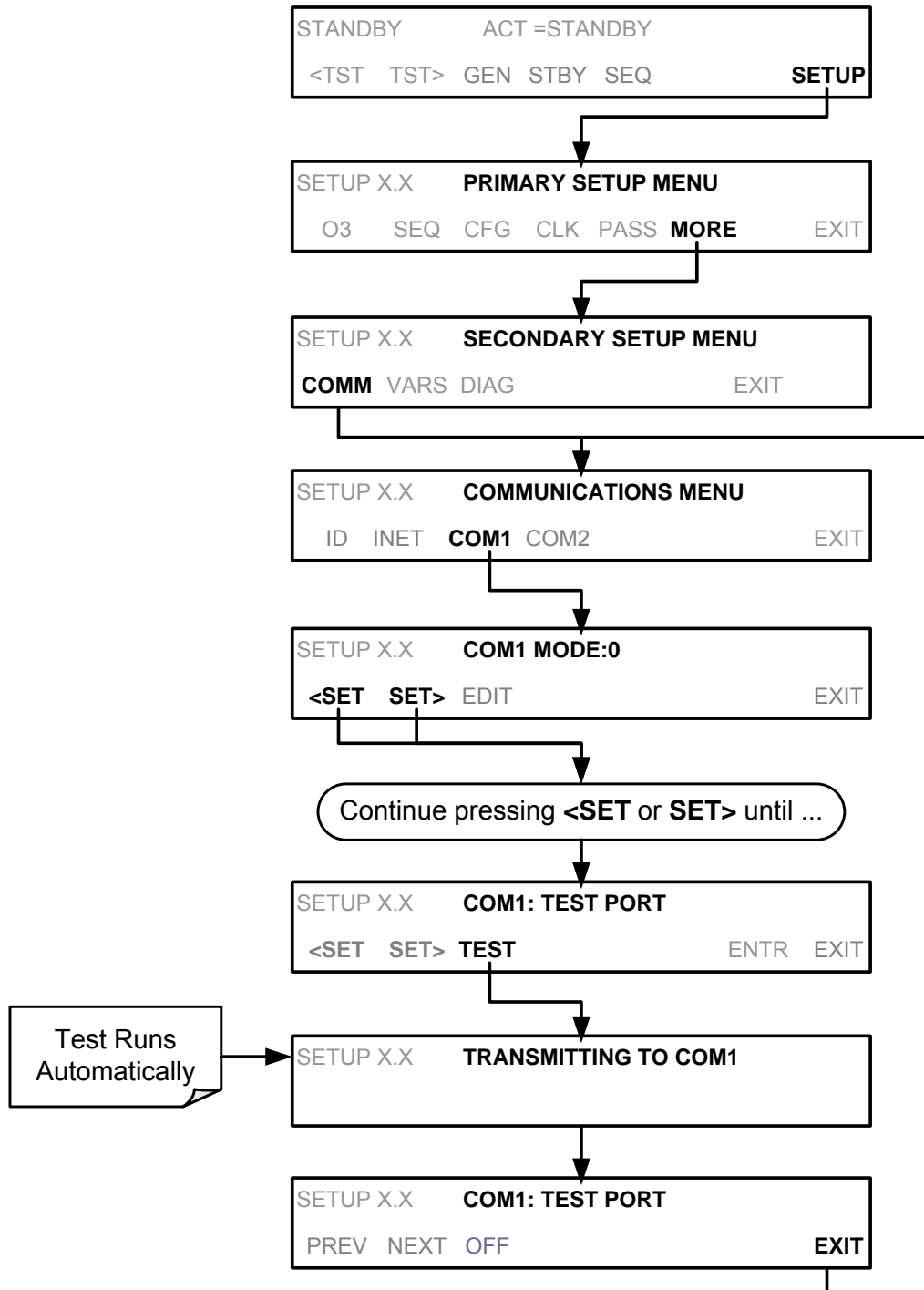

5.1.6. MACHINE ID

Each model of Teledyne API instruments is initially configured with a default Machine ID code, which is editable; all T703 calibrators have a Machine ID of either **703** or **0**. The Machine ID number is only important if more than one calibrator is connected to the same communications channel such as when several calibrators are on the same Ethernet LAN, in a RS-232 multidrop chain (See Section 5.3) or operating over a RS-485 network (See Section 5.4): If two calibrators of the same model type are used on one channel, their Machine ID numbers must differ.

To edit the instrument's Machine ID, press:

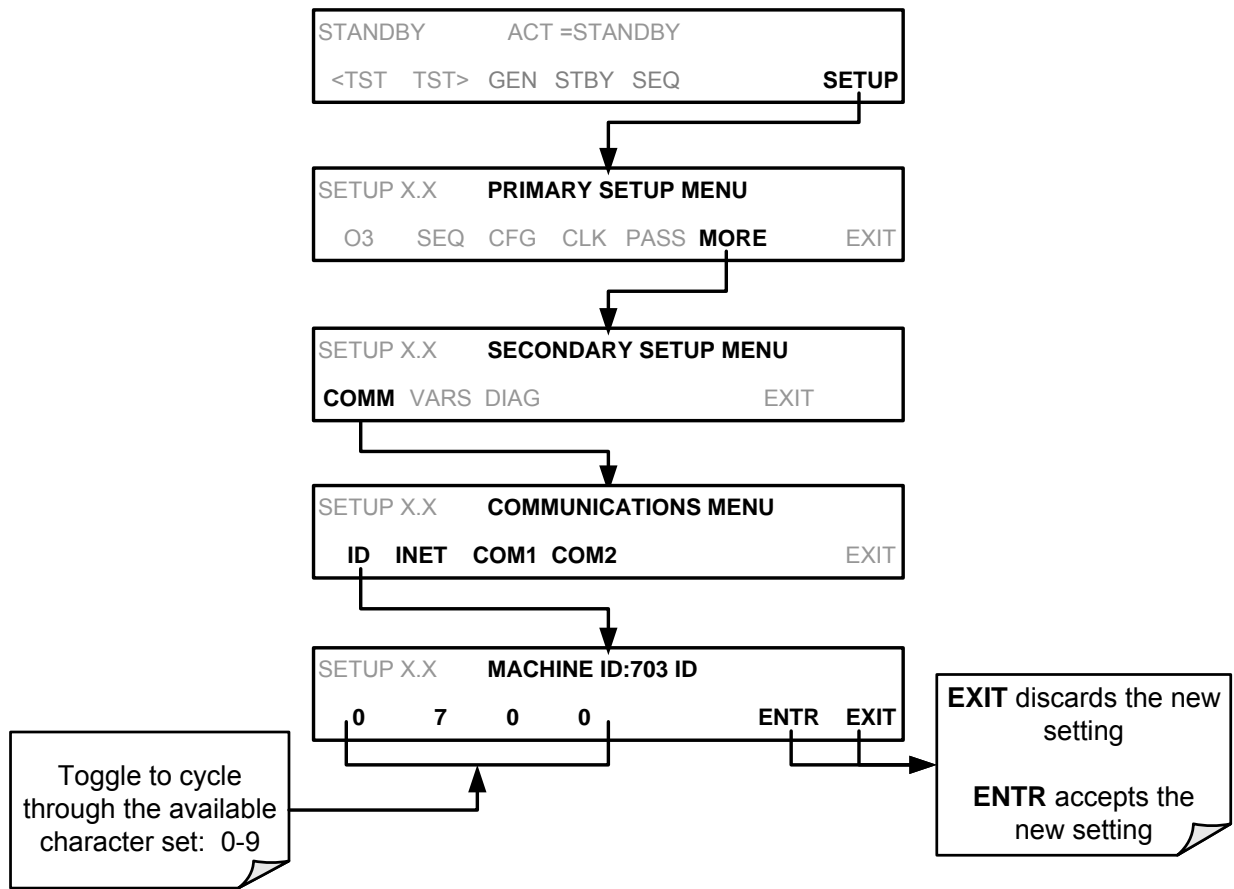

The ID number is only important if more than one calibrator is connected to the same communications channel (e.g., a multi-drop setup). Different models of Teledyne API's calibrators have different default ID numbers, but if two calibrators of the same model type are used on one channel (for example, two T703's), the ID of one instrument needs to be changed.

The ID can also be used for to identify any one of several calibrators attached to the same network but situated in different physical locations.

5.1.7. TERMINAL OPERATING MODES

The T703 can be remotely configured, calibrated or queried for stored data through the serial ports. As terminals and computers use different communication schemes, the calibrator supports two communicate modes specifically designed to interface with these two types of devices.

- Computer mode is used when the calibrator is connected to a computer with a dedicated interface program.
- Interactive mode is used with a terminal emulation programs such as HyperTerminal or a “dumb” computer terminal. The commands that are used to operate the calibrator in this mode are listed in Table 5-2.

5.1.7.1. Help Commands in Terminal Mode

Table 5-2: Terminal Mode Software Commands

COMMAND	Function
Control-T	Switches the calibrator to terminal mode (echo, edit). If mode flags 1 & 2 are OFF, the interface can be used in interactive mode with a terminal emulation program.
Control-C	Switches the calibrator to computer mode (no echo, no edit).
CR (carriage return)	A carriage return is required after each command line is typed into the terminal/computer. The command will not be sent to the calibrator to be executed until this is done. On personal computers, this is achieved by pressing the ENTER key.
BS (backspace)	Erases one character to the left of the cursor location.
ESC (escape)	Erases the entire command line.
? [ID] CR	This command prints a complete list of available commands along with the definitions of their functionality to the display device of the terminal or computer being used. The ID number of the calibrator is only necessary if multiple calibrators are on the same communications line, such as the multi-drop setup.
Control-C	Pauses the listing of commands.
Control-P	Restarts the listing of commands.

5.1.7.2. Command Syntax

Commands are not case-sensitive and all arguments within one command (i.e. ID numbers, keywords, data values, etc.) must be separated with a space character.

All Commands follow the syntax:

X [ID] COMMAND <CR>

Where:

X is the command type (one letter) that defines the type of command. Allowed designators are listed in Table 5-2 and in Appendix A

[ID] is the machine identification number (Section 5.1.6). Example: the Command “? 200” followed by a carriage return would print the list of available commands for the revision of software currently installed in the instrument assigned ID Number 200.

COMMAND is the command designator: This string is the name of the command being issued (LIST, ABORT, NAME, EXIT, etc.). Some commands may have additional arguments that define how the command is to be executed. Press ? <CR> or refer to Appendix A for a list of available command designators.

<CR> is a carriage return. All commands must be terminated by a carriage return (usually achieved by pressing the ENTER key on a computer).

Table 5-3: Teledyne API Serial I/O Command Types

COMMAND	COMMAND TYPE
C	Calibration
D	Diagnostic
L	Logon
T	Test measurement
V	Variable
W	Warning

5.1.7.3. Data Types

Data types consist of integers, hexadecimal integers, floating-point numbers, Boolean expressions and text strings.

- Integer data are used to indicate integral quantities such as a number of records, a filter length, etc. They consist of an optional plus or minus sign, followed by one or more digits. For example, *+1*, *-12*, *123* are all valid integers.
- Hexadecimal integer data are used for the same purposes as integers. They consist of the two characters "0x," followed by one or more hexadecimal digits (0-9, A-F, a-f), which is the 'C' programming language convention. No plus or minus sign is permitted. For example, *0x1*, *0x12*, *0x1234abcd* are all valid hexadecimal integers.
- Floating-point numbers are used to specify continuously variable values such as temperature set points, time intervals, warning limits, voltages, etc. They consist of an optional plus or minus sign, followed by zero or more digits, an optional decimal point and zero or more digits. (At least one digit must appear before or after the decimal point.) Scientific notation is not permitted. For example, *+1.0*, *1234.5678*, *-0.1*, *1* are all valid floating-point numbers.
- Boolean expressions are used to specify the value of variables or I/O signals that may assume only two values. They are denoted by the keywords *ON* and *OFF*.
- Text strings are used to represent data that cannot be easily represented by other data types, such as data channel names, which may contain letters and numbers. They consist of a quotation mark, followed by one or more printable characters, including spaces, letters, numbers, and symbols, and a final quotation mark. For example, *"a"*, *"1"*, *"123abc"*, and *"()[]<>"* are all valid text strings. It is not possible to include a quotation mark character within a text string.
- Some commands allow you to access variables, messages, and other items. When using these commands, you must type the entire name of the item; you cannot abbreviate any names.

5.1.7.4. Status Reporting

Reporting of status messages as an audit trail is one of the three principal uses for the RS-232 interface (the other two being the command line interface for controlling the instrument and the download of data in electronic format). You can effectively disable the reporting feature by setting the interface to quiet mode (Section 5.1.4, Table 5-1).

Status reports include warning messages, calibration and diagnostic status messages. Refer to Appendix A for a list of the possible messages, and this for information on controlling the instrument through the RS-232 interface.

5.1.7.5. General Message Format

All messages from the instrument (including those in response to a command line request) are in the format:

```
X DDD:HH:MM [Id] MESSAGE<CRLF>
```

Where:

- X is a command type designator, a single character indicating the message type, as shown in the Table 6-27.
- DDD:HH:MM is the time stamp, the date and time when the message was issued. It consists of the Day-of-year (DDD) as a number from 1 to 366, the hour of the day (HH) as a number from 00 to 23, and the minute (MM) as a number from 00 to 59.
- [ID] is the calibrator ID, a number with 1 to 4 digits.
- MESSAGE is the message content that may contain warning messages, Test Functions, variable values, etc.
- <CRLF> is a carriage return / line feed pair, which terminates the message.

The uniform nature of the output messages makes it easy for a host computer to parse them into an easy structure. Keep in mind that the front panel display does not give any information on the time a message was issued, hence it is useful to log such messages for trouble-shooting and reference purposes. Terminal emulation programs such as HyperTerminal can capture these messages to text files for later review.

5.1.7.6. COM Port Password Security

In order to provide security for remote access of the T703, a LOGON feature can be enabled to require a password before the instrument will accept commands. This is done by turning on the **SECURITY MODE** (Mode 4, Section 5.1.4). Once the **SECURITY MODE** is enabled, the following items apply.

- A password is required before the port will respond or pass on commands.
- If the port is inactive for one hour, it will automatically logoff, which can also be achieved with the LOGOFF command.
- Three unsuccessful attempts to log on with an incorrect password will cause subsequent logins to be disabled for 1 hour, even if the correct password is used.
- If not logged on, the only active command is the '?' request for the help screen.
- The following messages will be returned at logon:
 - LOGON SUCCESSFUL - Correct password given
 - LOGON FAILED - Password not given or incorrect
 - LOGOFF SUCCESSFUL - Connection terminated successfully

To log on to your calibrator with **SECURITY MODE** feature enabled, type:

```
LOGON 940331
```

940331 is the default password. To change the default password, use the variable RS232_PASS issued as follows:

```
V RS232_PASS=NNNNNN
```

Where N is any numeral between 0 and 9.

5.2. REMOTE ACCESS BY MODEM

The T703 can be connected to a modem for remote access. This requires a cable between the calibrator's COM port and the modem, typically a DB-9F to DB-25M cable (available from Teledyne API with part number WR0000024).

Once the cable has been connected, check to make sure:

- The DTE-DCE is in the DCE position.
- The T703 COM port is set for a baud rate that is compatible with the modem,
- The Modem is designed to operate with an 8-bit word length with one stop bit.
- The **MODEM ENABLE** communication mode is turned **ON** (Mode 64, see Section 5.1.4).

Once this is completed, the appropriate setup command line for your modem can be entered into the calibrator. The default setting for this feature is

AT Y0 &D0 &H0 &I0 S0=2 &B0 &N6 &M0 E0 Q1 &W0

This string can be altered to match your modem's initialization and can be up to 100 characters long.

To change this setting press:

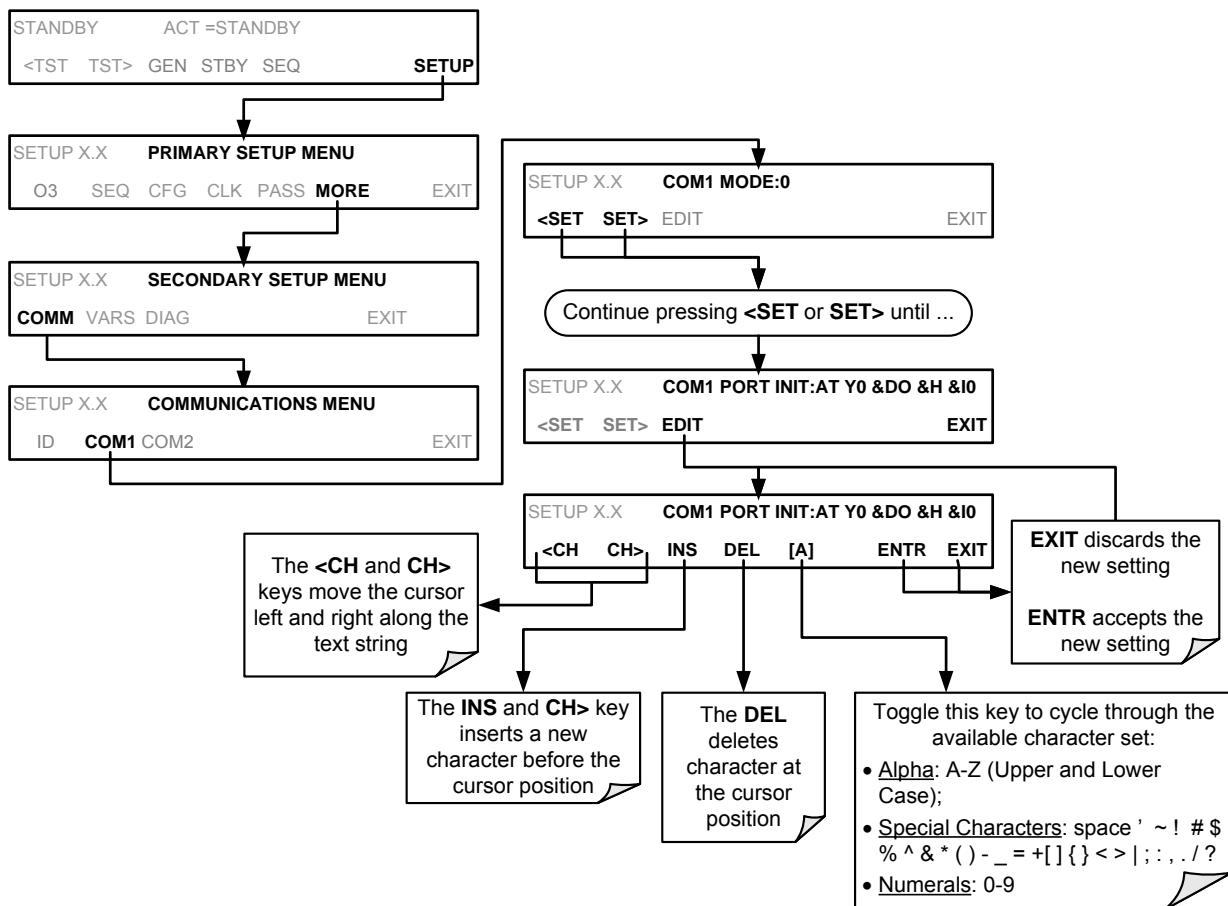

To Initialize the modem press:

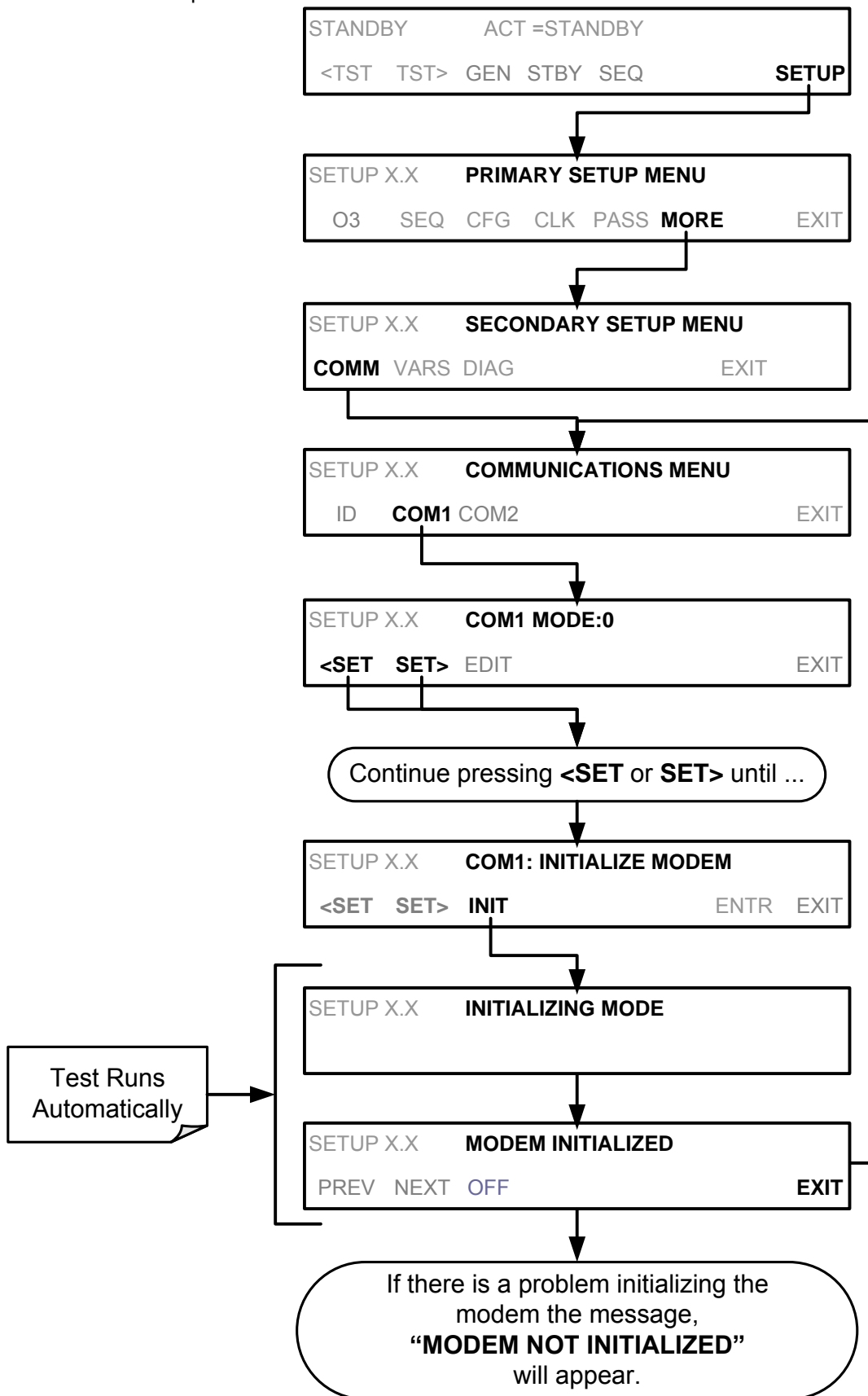

5.3. MULTIDROP RS-232 SET UP

When the RS-232 Multidrop option is installed, connection adjustments and configuration through the menu system are required. This section provides instructions for the internal connection adjustments, then for external connections, and ends with instructions for menu-driven configuration.

Note that because the RS-232 Multidrop option uses both the **RS232** and **COM2** DB9 connectors on the instrument's rear panel to connect the chain of instruments, **COM2** port is no longer available for separate RS-232 or RS-485 operation.



CAUTION – Risk of Instrument Damage and Warranty Invalidation

Printed circuit assemblies (PCAs) are sensitive to electro-static discharges too small to be felt by the human nervous system. Damage resulting from failure to use ESD protection when working with electronic assemblies will void the instrument warranty.

For more information on preventing ESD damage see *A Primer on Electro-Static Discharge*; the manual can be downloaded from our website at <http://www.teledyne-api.com> under Help Center > Product Manuals in the Special Manuals section.

In each instrument with the Multidrop option there is a shunt jumpering two pins on the serial Multidrop and LVDS printed circuit assembly (PCA), as shown in Figure 5-3. This shunt must be removed from all instruments except that designated as last in the multidrop chain, which must remain terminated. This requires powering off and opening each instrument and making the following adjustments:

1. With **NO power** to the instrument, remove its top cover and lay the rear panel open for access to the Multidrop/LVDS PCA, which is seated on the CPU.
2. On the Multidrop/LVDS PCA's JP2 connector, remove the shunt that jumpers Pins 21 ↔ 22 as indicated in Figure 5-3. (Do this for all but the last instrument in the chain where the shunt should remain at Pins 21 ↔ 22).
3. Check that the following cable connections are made in *all* instruments (again refer to Figure 5-3):
 - J3 on the Multidrop/LVDS PCA to the CPU's COM1 connector
(Note that the CPU's COM2 connector is not used in Multidrop)
 - J4 on the Multidrop/LVDS PCA to J12 on the motherboard
 - J1 on the Multidrop/LVDS PCS to the front panel LCD

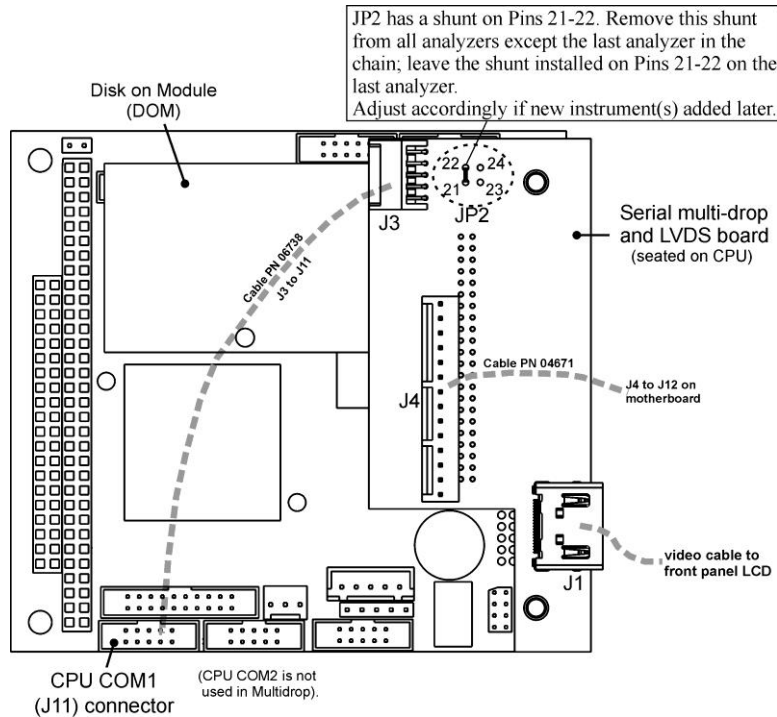

Figure 5-3: Jumper and Cables for Multidrop Mode

4. Close the instrument.
5. Referring to Figure 5-4, use straight-through DB9 male-DB9 female cables to interconnect the host RS232 port to the first instrument's RS232 port; then from the first instrument's COM2 port to the second instrument's RS232 port; from the second instrument's COM2 port to the third instrument's RS232 port, etc., connecting in this fashion up to eight instruments, subject to the distance limitations of the RS-232 standard.
6. On the rear panel of each instrument, adjust the DCE DTE switch so that the green and the red LEDs (RX and TX) of the COM1 connector (labeled RS232) are both lit. (Ensure you are using the correct RS-232 cables internally wired specifically for RS-232 communication).
7. BEFORE communicating from the host, power on the instruments and check that the Machine ID (Section 5.6.2) is unique for each.
 - a. In the SETUP Model menu, use SETUP>MORE>COMM>ID. The default ID is typically either the model number or "0".
 - b. To change the identification number, press the button below the digit to be changed.
 - c. Press/select ENTR to accept the new ID for that instrument.
8. Next, in the SETUP>MORE>COMM>COM1 menu (do not use the COM2 menu for multidrop), edit the COM1 MODE parameter as follows: press/select EDIT and set only QUIET MODE, COMPUTER MODE, and MULTIDROP MODE to ON. Do not change any other settings.
9. Press/select ENTER to accept the changed settings, and ensure that COM1 MODE now shows 35.

10. Press/select SET> to go to the COM1 BAUD RATE menu and ensure it reads the same for all instruments (edit as needed so that all instruments are set at the same baud rate).

NOTE:

Teledyne API recommends setting up the first link, between the Host and the first instrument and testing it before setting up the rest of the chain.

The (communication) Host instrument can address only one instrument at a time, each by its unique ID (see Step 7 above).

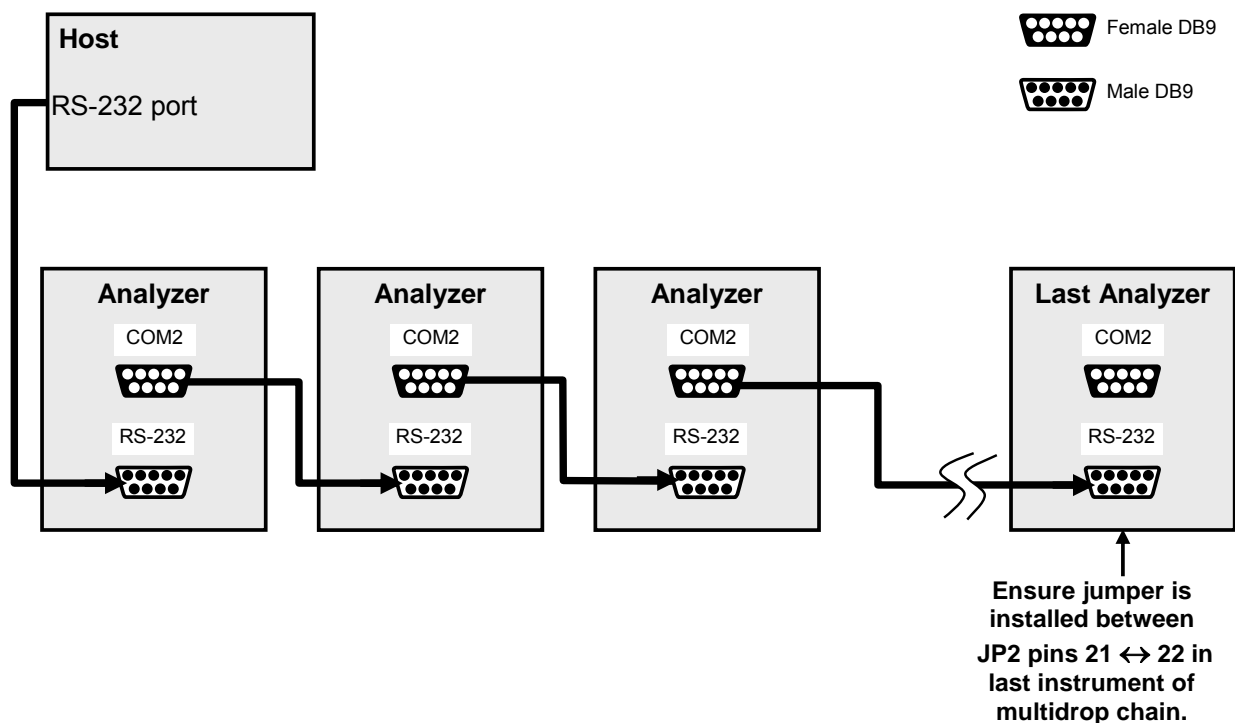

Figure 5-4: RS232-Multidrop PCA Host/Calibrator Interconnect Diagram

5.4. RS-485 CONFIGURATION OF COM2

As delivered from the factory, COM2 is configured for RS-232 communications. This port can be reconfigured for operation as a non-isolated, half-duplex RS-485 port. To configure the instrument for RS-485 communication, please contact the factory. (Using COM2 for RS-485 communications disables the optional USB com port).

5.5. REMOTE ACCESS VIA THE USB PORT (OPTION)

The calibrator can be connected to a personal computer by direct connection through their respective USB ports.

1. Install the Teledyne T-Series USB driver on your computer, downloadable from the Teledyne API website under Help Center>Software Downloads (www.teledyne-api.com/software).
2. Run the installer file: "TAPIVCPInstaller.exe"

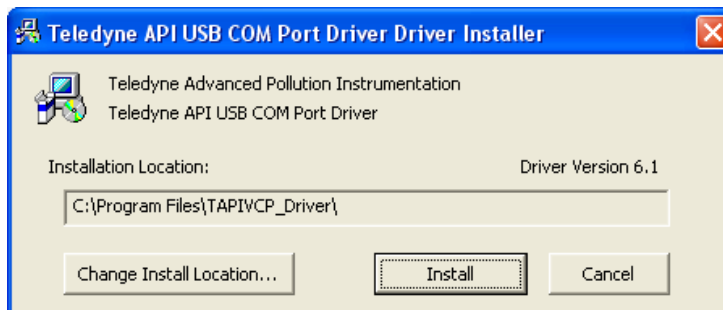

3. Connect the USB cable between the USB ports on your personal computer and your calibrator. The USB cable should be a Type A – Type B cable, commonly used as a USB printer cable.
4. Determine the Windows XP Com Port number that was automatically assigned to the USB connection. (Start → Control Panel → System → Hardware → Device Manager). This is the com port that should be set in the communications software, such as APIcom or Hyperterminal.

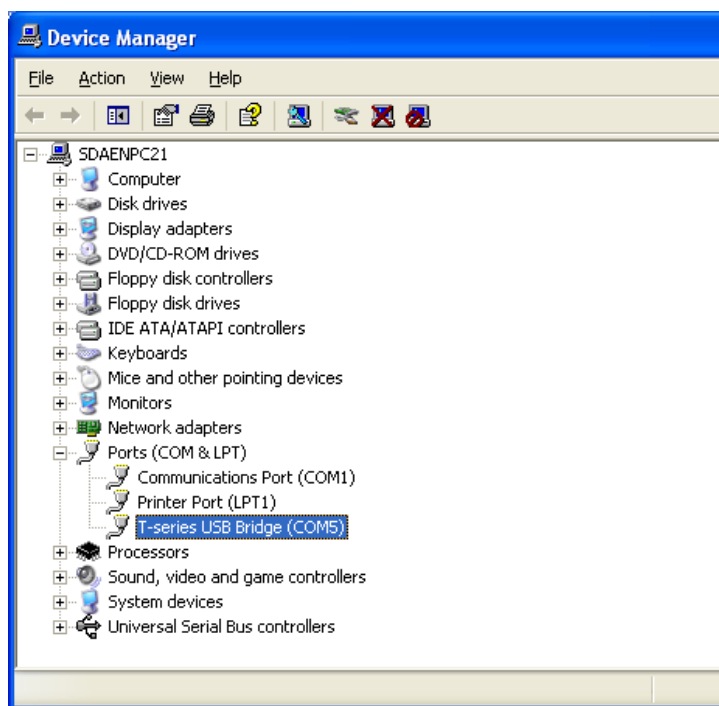

Refer to the *Quick Start (Direct Cable Connection)* section of the Teledyne APIcom Manual, PN 07463.

5. In the instrument's SETUP>MORE>COMM>COM2 menu, make the following settings:

Baud Rate: 115200

COM2 Mode Settings:

Quiet Mode	ON
Computer Mode	ON
MODBUS RTU	OFF
MODBUS ASCII	OFF
E,8,1 MODE	OFF
E,7,1 MODE	OFF
RS-485 MODE	OFF
SECURITY MODE	OFF
MULTIDROP MODE	OFF
ENABLE MODEM	OFF
ERROR CHECKING	ON
XON/XOFF HANDSHAKE	OFF
HARDWARE HANDSHAKE	OFF
HARDWARE FIFO	ON
COMMAND PROMPT	OFF

5.6. REMOTE ACCESS VIA THE ETHERNET

The calibrator can be connected to any standard 10Base-T or 100Base-T Ethernet network via low-cost network hubs, switches or routers. The interface operates as a standard TCP/IP device on port 3000. This allows a remote computer to connect through the internet to the calibrator using APICOM, terminal emulators or other programs.

Under the SETUP>MORE>COMM menu the **INET** submenu is used to manage and configure the Ethernet interface with your LAN or Internet Server(s). The calibrator is shipped with DHCP enabled by default. This allows the instrument to be connected to a network or router with a DHCP server, but for a permanent Ethernet connection, configure the instrument with a static IP address (Section 5.6.1.1).

The Ethernet LEDs located on the connector indicate the Ethernet connection status.

Table 5-4: Ethernet Status Indicators

LED	FUNCTION
amber (link)	On when connection to the LAN is valid.
green (activity)	Flickers during any activity on the LAN.

5.6.1. CONFIGURING THE ETHERNET INTERFACE USING DHCP

The Ethernet feature for your T703 uses Dynamic Host Configuration Protocol (DHCP) to configure its interface with your LAN automatically. This requires your network servers also be running DHCP. The calibrator will do this the first time you turn the instrument on after it has been physically connected to your network. Once the instrument is connected and turned on, it will appear as an active device on your network without any extra set up steps or lengthy procedures.

NOTE

It is a good idea to check the INET settings the first time you power up your calibrator after it has been physically connected to the LAN/Internet to make sure that the DHCP has successfully downloaded the appropriate information from you network server(s).

The Ethernet configuration properties are viewable via the calibrator's front panel.

Table 5-5: LAN/Internet Configuration Properties

PROPERTY	DEFAULT STATE	DESCRIPTION
DHCP STATUS	ON	This displays whether the DHCP is turned ON or OFF.
INSTRUMENT IP ADDRESS	0.0.0.0	This string of four packets of 1 to 3 numbers each (e.g. 192.168.76.55.) is the address of the calibrator itself.
GATEWAY IP ADDRESS	0.0.0.0	A string of numbers very similar to the Instrument IP address (e.g. 192.168.76.1.) that is the address of the computer used by your LAN to access the Internet.
SUBNET MASK	0.0.0.0	Also, a string of four packets of 1 to 3 numbers each (e.g. 255.255.252.0) that defines that identifies the LAN to which the device is connected. All addressable devices and computers on a LAN must have the same subnet mask. Any transmissions sent devices with different subnet masks are assumed to be outside of the LAN and are routed through a different gateway computer onto the Internet.
TCP PORT¹	3000	This number defines the terminal control port by which the instrument is addressed by terminal emulation software, such as Internet or Teledyne API's APICOM.
HOST NAME	T703	The name by which your calibrator will appear when addressed from other computers on the LAN or via the Internet. While the default setting for all Teledyne API's T703 calibrators is "T703", the host name may be changed to fit customer needs.

¹ Do not change the setting for this property unless instructed to by Teledyne API's Technical Support personnel.

NOTE

If the gateway IP, instrument IP and the subnet mask are all zeroes (e.g. "0.0.0.0"), the DCHP was not successful in which case you may have to configure the calibrator's Ethernet properties manually.

See your network administrator.

To view the above properties listed in Table 7-5, press:

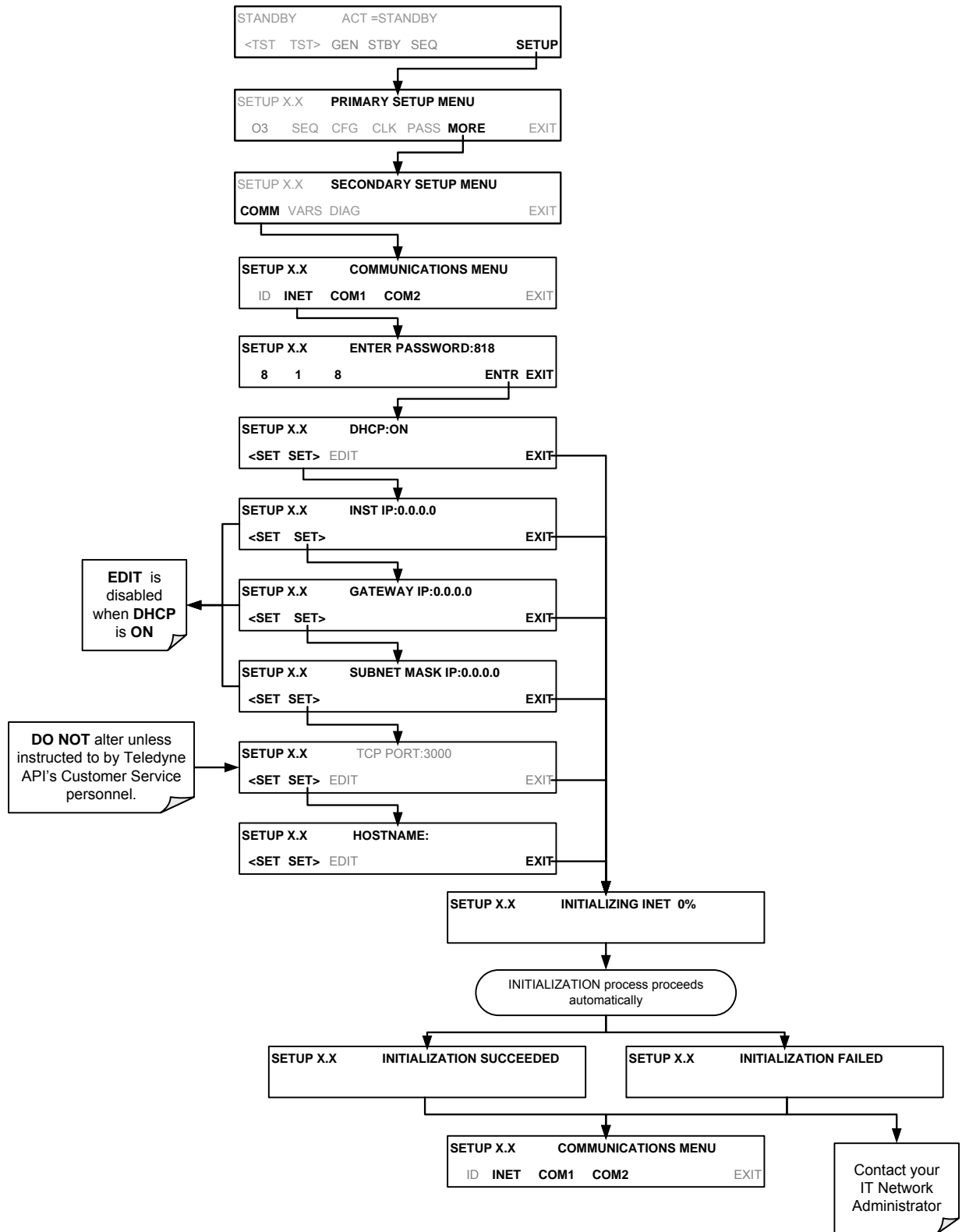

5.6.1.1. Manually Configuring the Network IP Addresses

Here are several circumstances when you may need to manually set the Ethernet configuration:

- Your LAN is not running a DHCP software package,
- The DHCP software is unable to initialize the calibrator's interface;
- You wish to configure the interface with a specific IP address, such as for a permanent Ethernet connection..

Manually configuring the Ethernet interface requires that you first turn DHCP to OFF before setting the **INSTRUMENT IP**, **GATEWAY IP** and **SUBNET MASK** parameters:

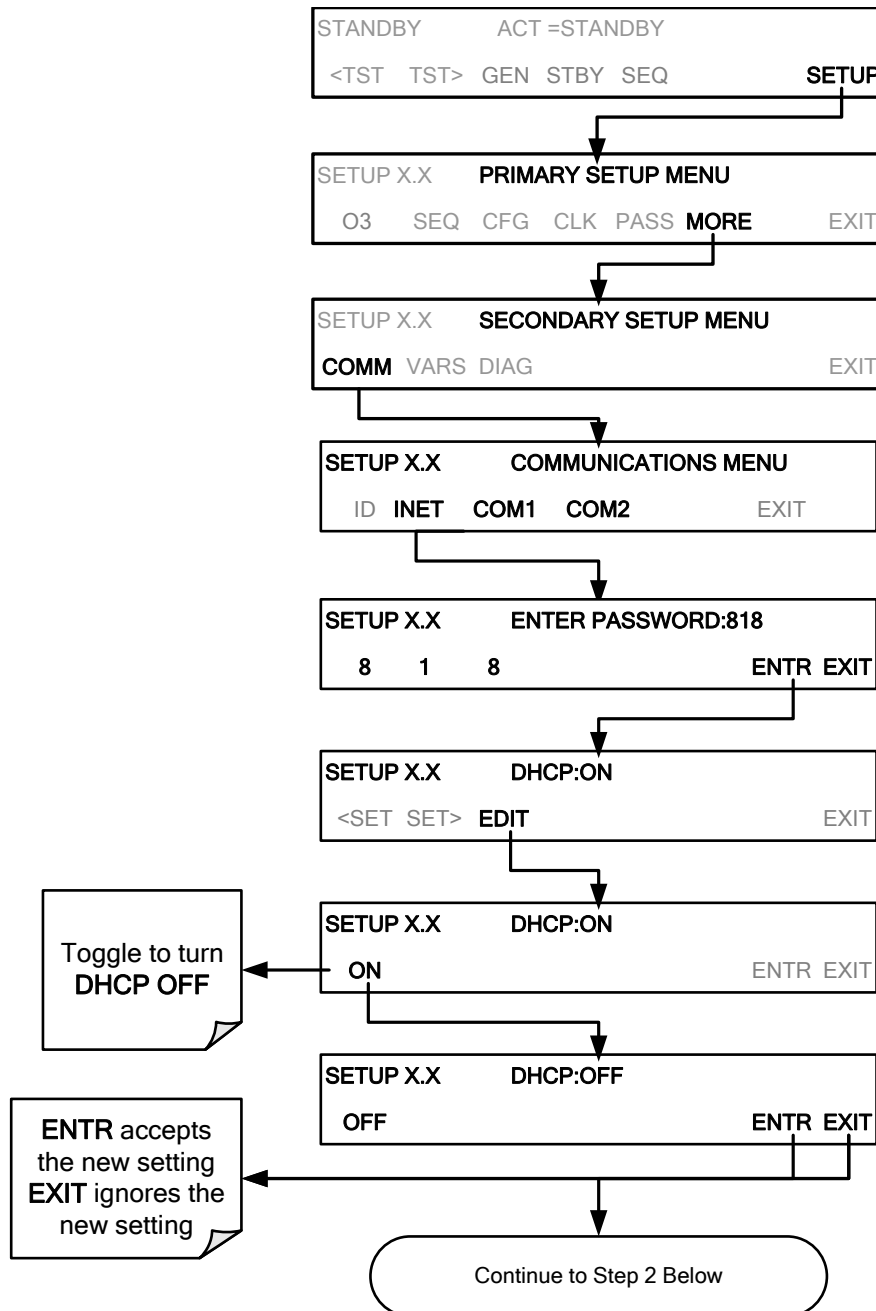

STEP 2: Configure the INSTRUMENT IP, GATEWAY IP and SUBNET MASK addresses by pressing:

Internet Configuration Touchscreen Button Functions

BUTTON	FUNCTION
[0]	Press to cycle through the range of numerals and available characters ("0-9" & ".")
<CH CH>	Moves the cursor one character left or right.
DEL	Deletes a character at the cursor location.
ENTR	Accepts the new setting and returns to the previous menu.
EXIT	Ignores the new setting and returns to the previous menu.

Some buttons only appear when applicable.

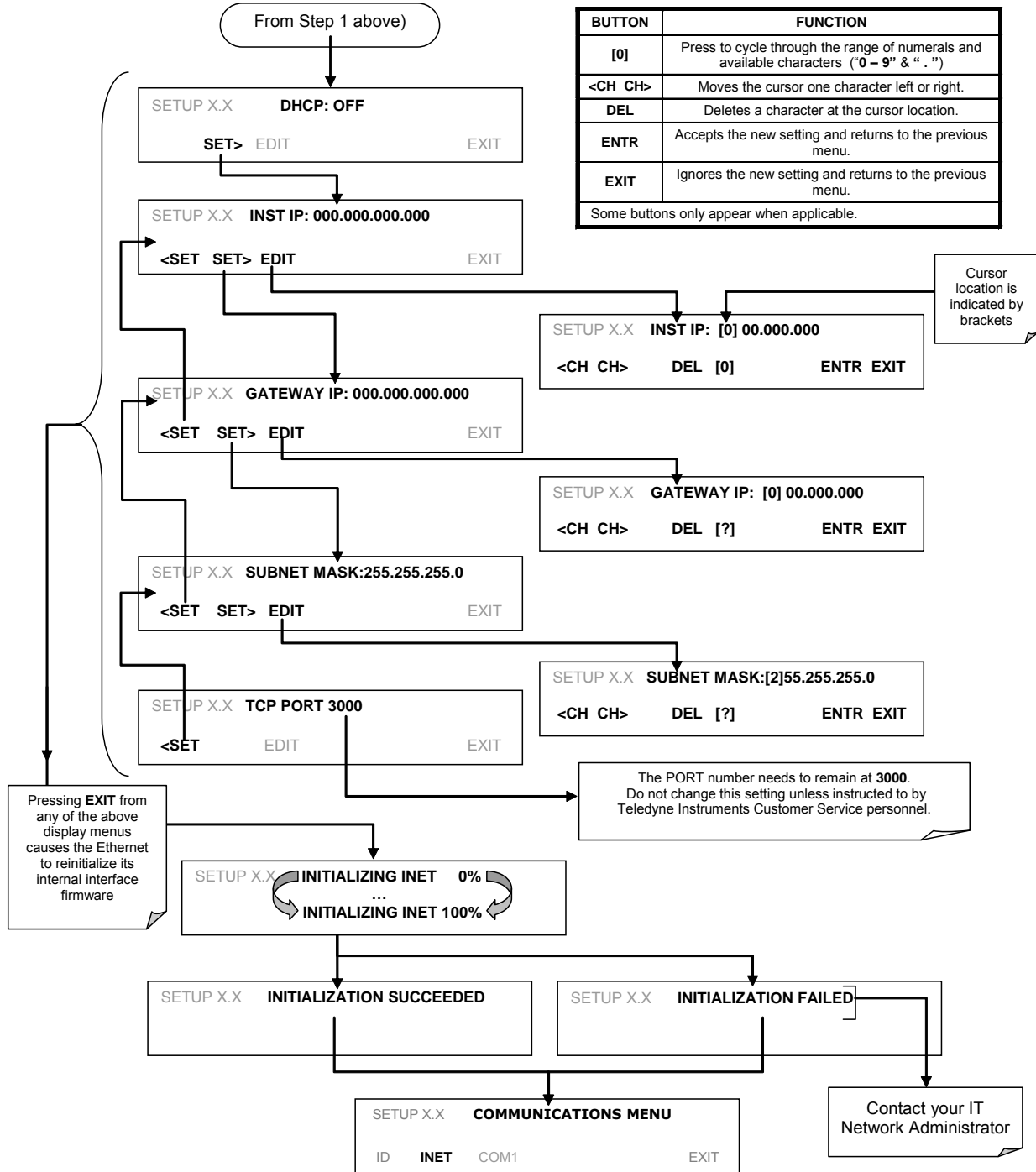

5.6.2. CHANGING THE CALIBRATOR'S HOSTNAME

The **HOSTNAME** is the name by which the calibrator appears on your network. The default name for all Teledyne API T703 calibrators is **T703**. To change this name (particularly if you have more than one T703 calibrator on your network), press.

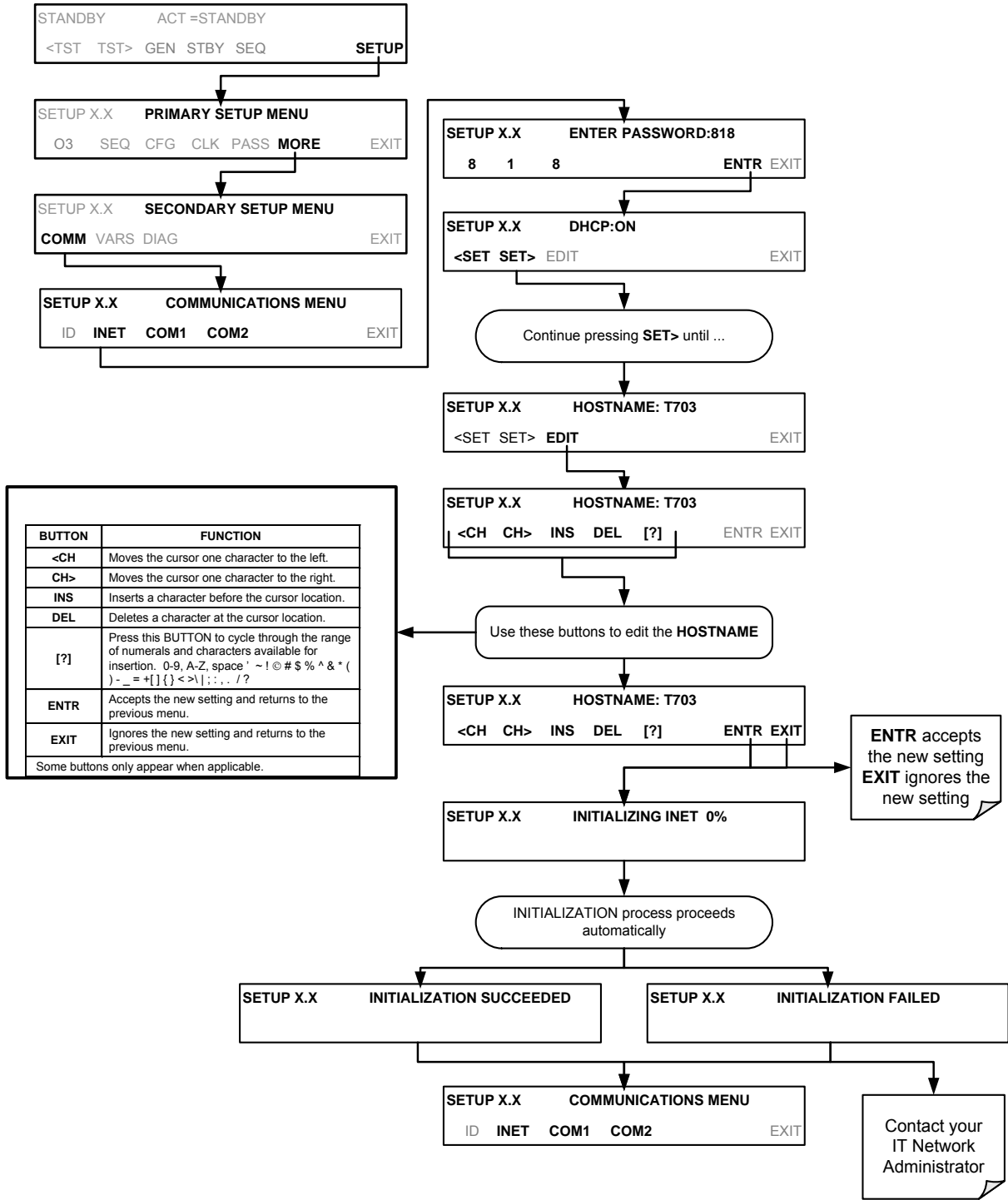

5.7. APICOM REMOTE CONTROL PROGRAM

APICOM is an easy-to-use, yet powerful interface program that allows the user to access and control any of Teledyne API's main line of ambient and stack-gas instruments from a remote connection through direct cable, modem or Ethernet. Running APICOM, a user can:

- Establish a link from a remote location to the T703 through direct cable connection via RS-232 modem or Ethernet.
- View the instrument's front panel and remotely access all functions that could be accessed when standing in front of the instrument.
- Remotely edit system parameters and set points.
- Download, view, graph and save data for predictive diagnostics or data analysis.
- Retrieve, view, edit, save and upload DAS configurations.
- Check on system parameters for trouble-shooting and quality control.

APICOM is very helpful for initial setup, data analysis, maintenance and trouble-shooting. Figure 5-5 shows examples of APICOM's main interface, which emulates the look and functionality of the instruments actual front panel

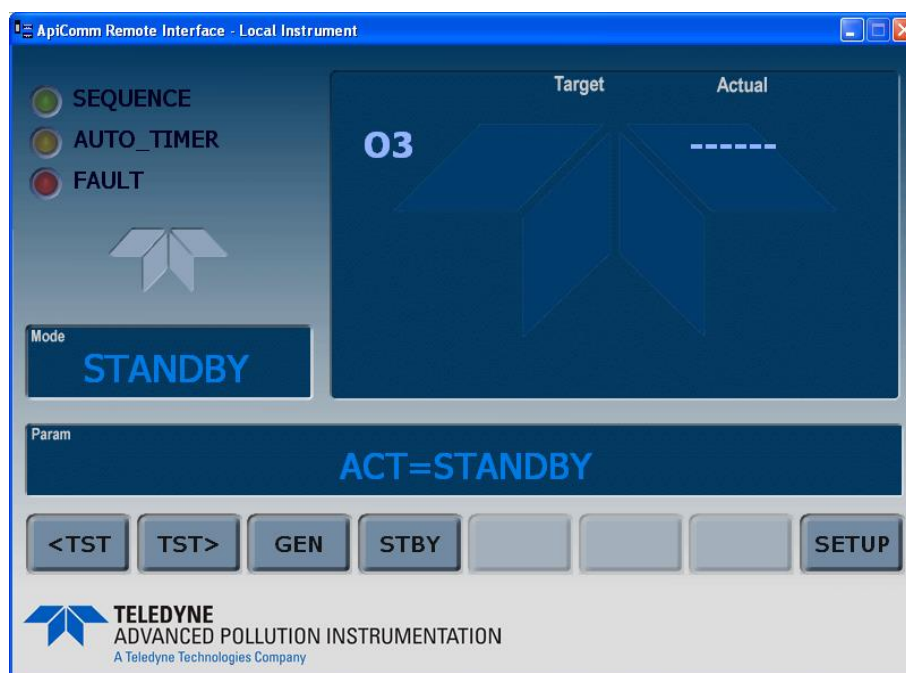

Figure 5-5: APICOM Remote Control Program Interface

NOTE

APICOM is included free of cost with the calibrator and the latest versions can also be downloaded for free at <http://www.teledyne-api.com/software/apicom/>.

The T703 calibrator is fully supported by APICOM revision 3.9.4 and later.

Instruments with the LEADS support option must run APICOM revision 4.0 and later

This page intentionally left blank.

6. CALIBRATION AND VERIFICATION

Basic electronic calibration of the Calibrator is performed at the factory. Normally there is no need to perform this factory calibration in the field however, the performance of several of the instrument's key subsystems should be verified periodically and if necessary adjusted. These subsystems are:

- O₃ Photometer: The O₃ photometer performance should be periodically verified against an external standard (see Section 6.1).
- O₃ Generator: The O₃ generator should be periodically calibrated (see Section 6.2).

6.1. VERIFYING/CALIBRATING THE O₃ PHOTOMETER

The accuracy of calibration gas produced by the T703 depends entirely on the accuracy of the photometer; therefore, it is very important that the photometer is operating properly and accurately.

The verification procedure can be performed using the instruments internal O₃ generator (see Figure 6-1) or an external source of O₃ (see Figure 6-2). In either case, an external source of zero air (such as a Teledyne API's Model 701 Zero Air Generator) is required.

6.1.1. SETUP FOR VERIFYING AND CALIBRATING THE O₃ PHOTOMETER

Note

This operation requires an external reference photometer.

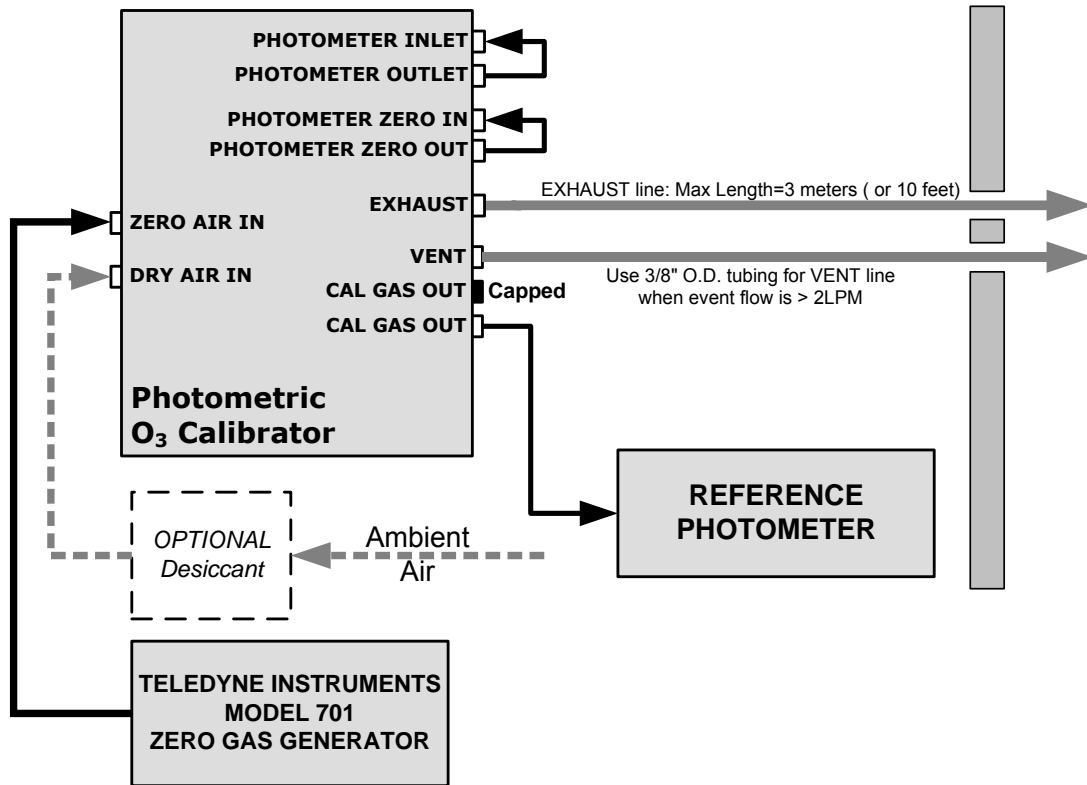

Figure 6-1: Set up for Verifying Optional O₃ Photometer Using Internal O₃ Generator

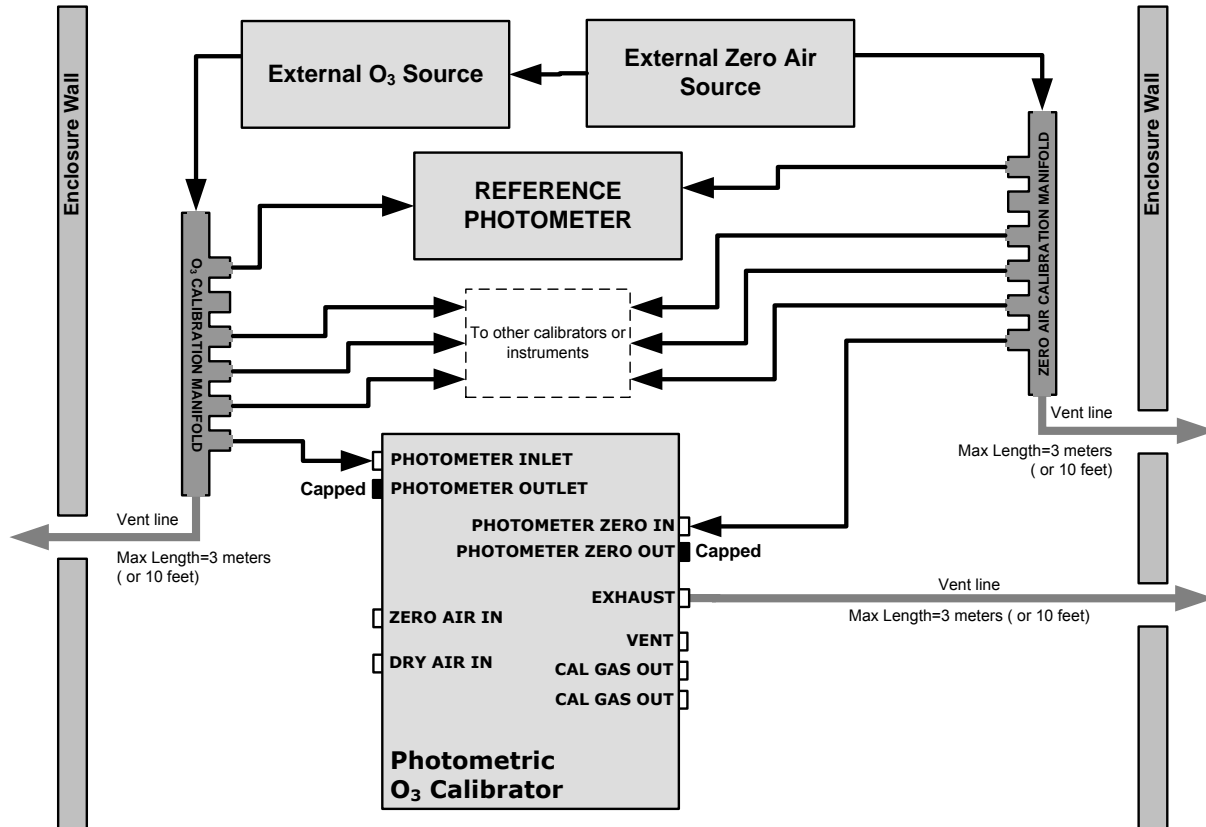

Figure 6-2: Set up for Verifying Optional O₃ Photometer Using an External O₃ Generator

NOTE

The manifolds as shown in the above drawing are oriented to simplify the drawing.

All unused ports should be capped.

A Minimum of 1.1 LPM is required for the external zero air source

6.1.1.1. Calibration Manifold Exhaust/Vent Line

The manifold's excess gas should be vented to a suitable vent outside of the room. This vent should be of large enough internal diameter to avoid any appreciable pressure drop, and it must be located sufficiently downstream of the output ports to assure that no ambient air enters the manifold due to eddy currents or back diffusion.

NOTE

It is recommended that the calibration manifold's exhaust vent have a minimum internal diameter of 3/8 inch and a maximum length of 3 meters (or 10 feet)

6.1.2. VERIFYING O₃ PHOTOMETER PERFORMANCE

To verify the performance of the internal photometer perform the following steps:

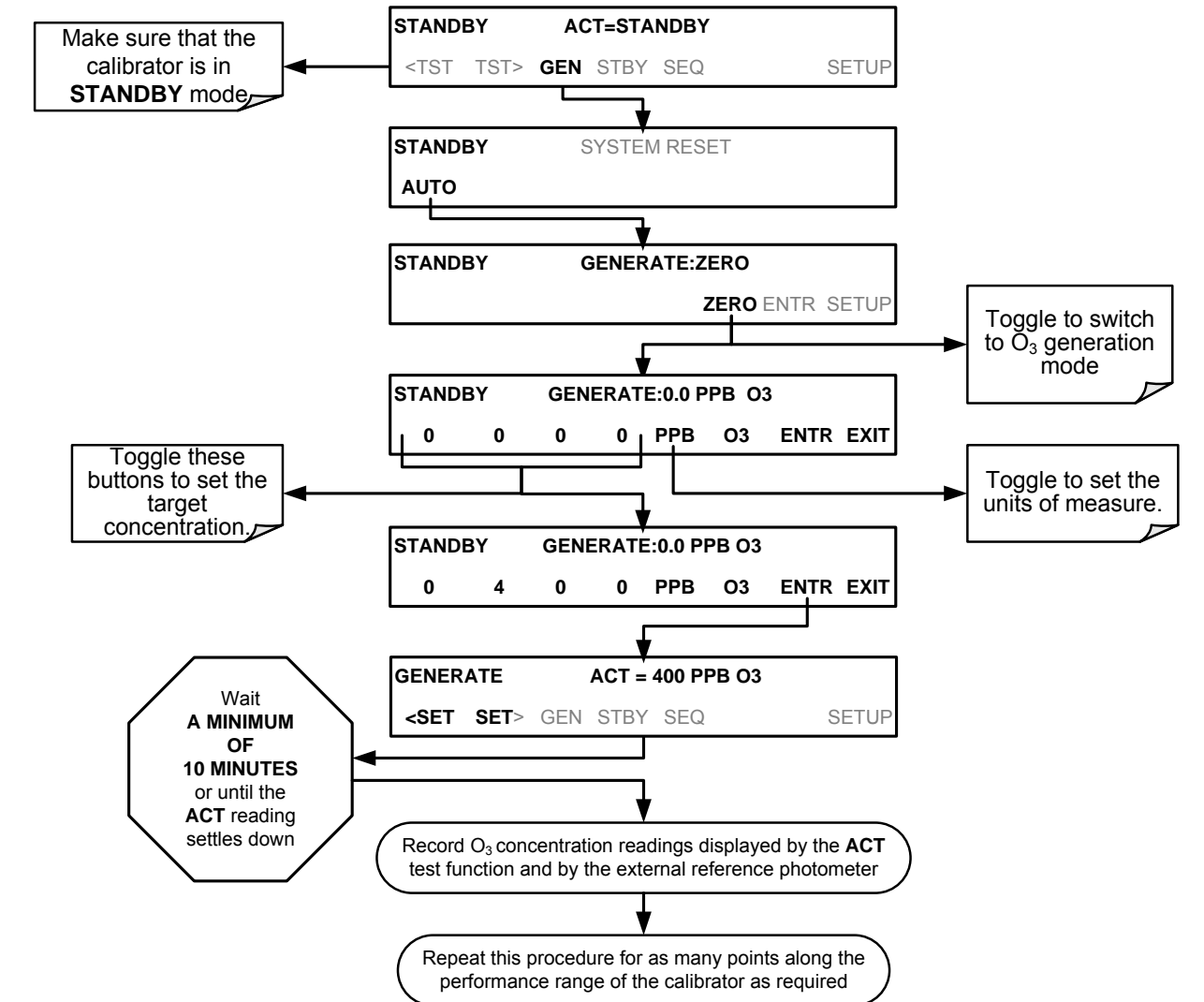

NOTE

The readings recorded from the ACT test function and the external reference photometer should be within 1% of each other.

6.1.3. CALIBRATING THE O₃ PHOTOMETER

The following procedure sets values held in the calibrator’s memory of for zero point **OFFSET** and **SLOPE**.

6.1.3.1. Photometer Zero Calibration

To set the zero point offset for the T703 Photometric Calibrator's photometer, press:

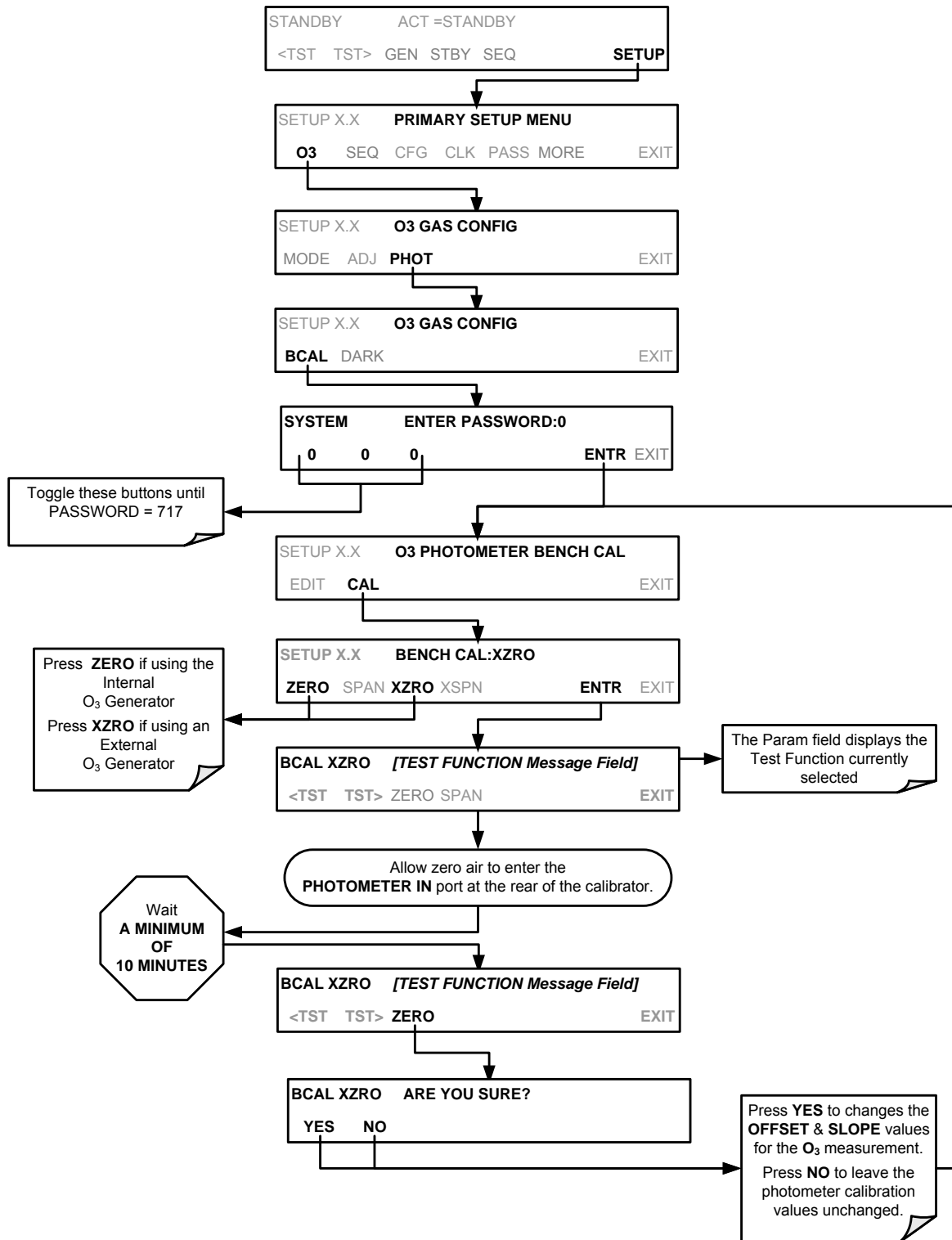

6.1.3.2. Photometer Span Calibration

To set the response SLOPE for the T703 Photometric Calibrator's photometer, press:

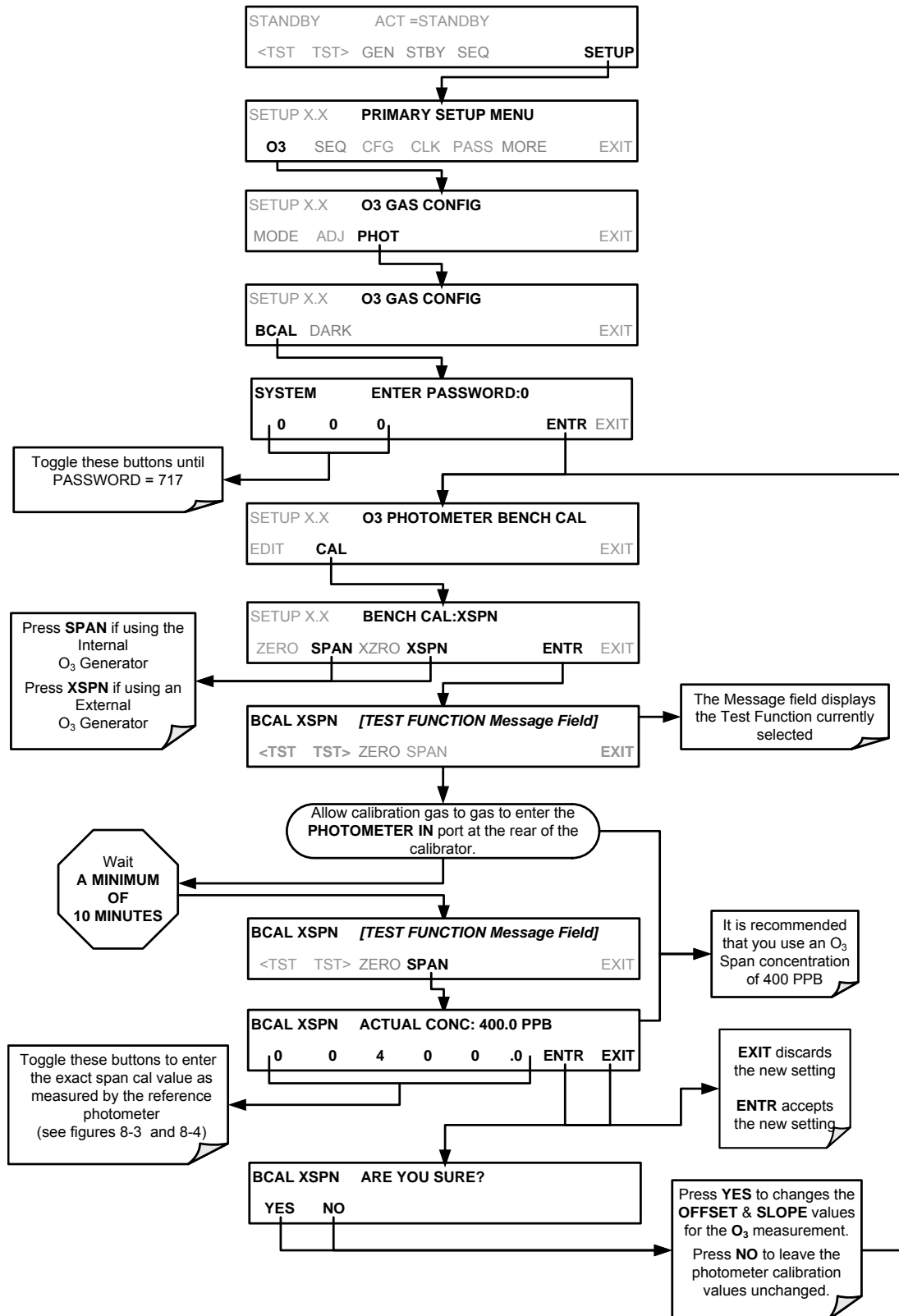

6.1.4. O₃ PHOTOMETER DARK CALIBRATION

The Dark Calibration Test turns off the Photometer UV Lamp and records any offset signal level of the UV Detector-Preamp-Voltage to Frequency Converter circuitry. This allows the instrument to compensate for any voltage levels inherent in the Photometer detection circuit that might affect the output of the detector circuitry and therefore the calculation of O₃ concentration.

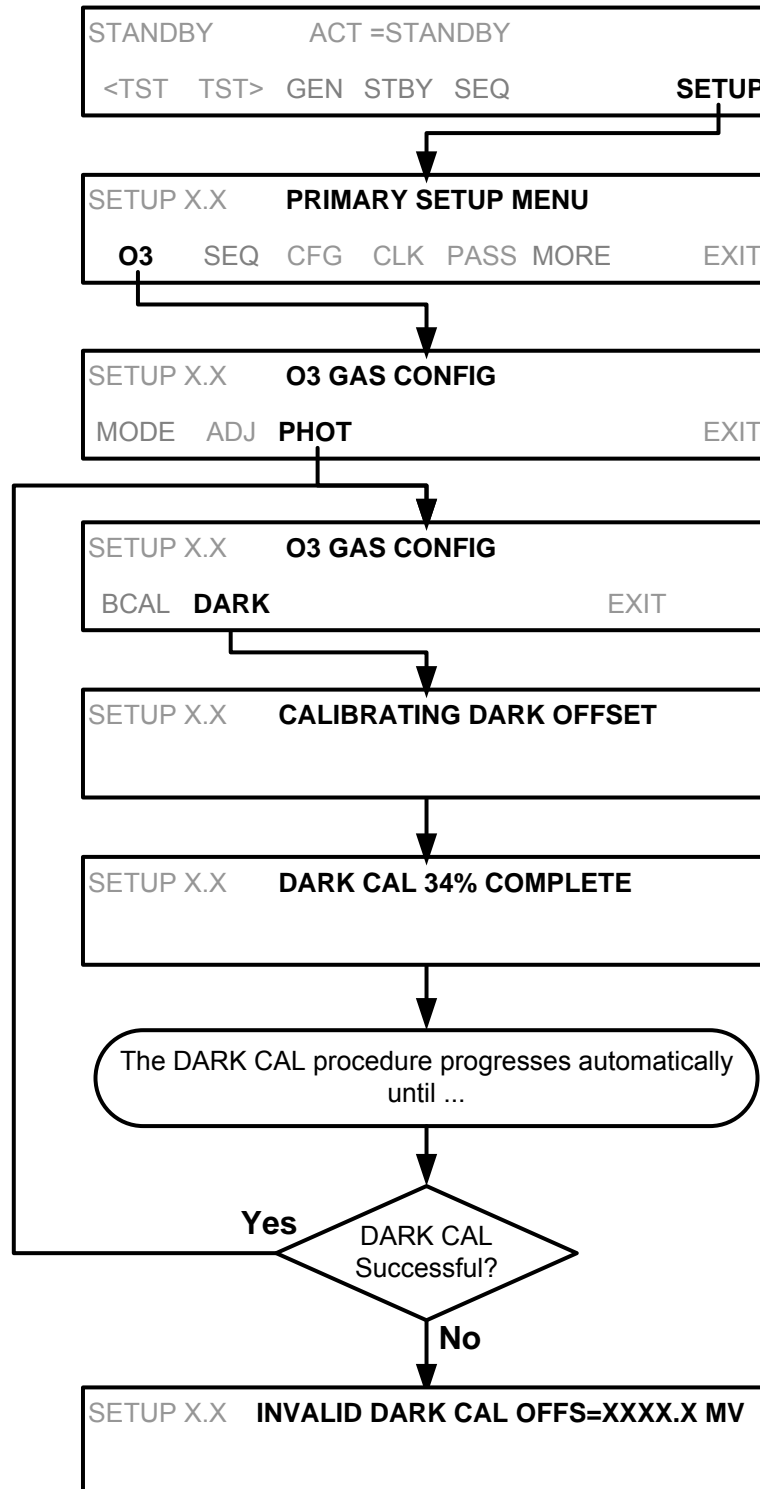

6.1.5. O₃ PHOTOMETER BACKPRESSURE COMPENSATION CALIBRATION

Any time there is a pneumatic configuration change, there is risk of impacting the internal measure/reference pressure. To compensate for this, a backpressure compensation calibration is required each time. Set the calibrator to generate ozone at the flow rate intended for operation. While the instrument is generating ozone, go to the **SETUP>MORE>DIAG>...>BACKPRESSURE COMPENSATION** menu and press **ENTR**, shown in the following illustration, to initiate the calibration; the operation will take a few minutes:

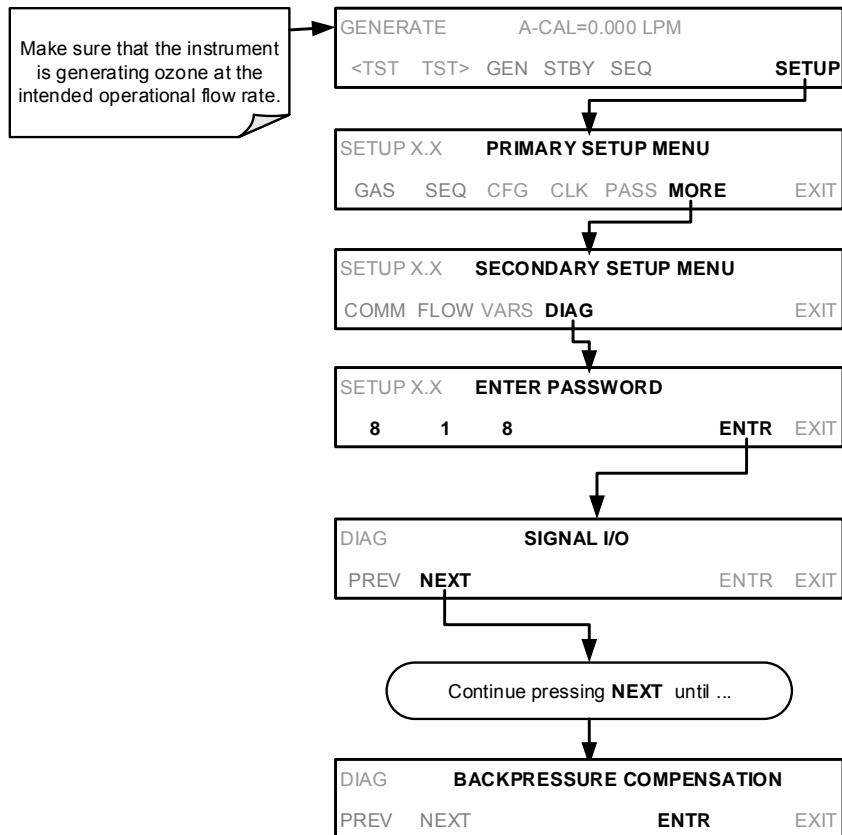

6.2. CALIBRATING THE O₃ GENERATOR

The T703/T703U calibrator’s software includes a routine for automatically calibrating the O₃ generator. A calibration table of drive voltages stored in the calibrator’s memory is the basis for this calibration. This table is used by the T703/T703U to set initial O₃ generator drive settings.

6.2.1. O₃ GENERATOR CALIBRATION TABLE

When the T703/T703U is operated in BENCH mode, this table is used for the initial setting only. After a short delay time, the bench feedback control will take over and control the O₃ generator drive voltage to match the concentration requested.

The instrument software will interpolate between two values in the table when an intermediate concentration is requested.

For each point included in the table used by the T703/T703U to calibrate the O₃ generator the user can set a drive voltage and a dwell time for that point. Each point can also be individually turned off or on.

When the T703/T703U is operated in CONST mode, the initial O₃ generator drive setting will be set by the calibration table and does not change.

6.2.2. VIEWING O₃ GENERATOR CALIBRATION POINTS

To view these calibration points, press:

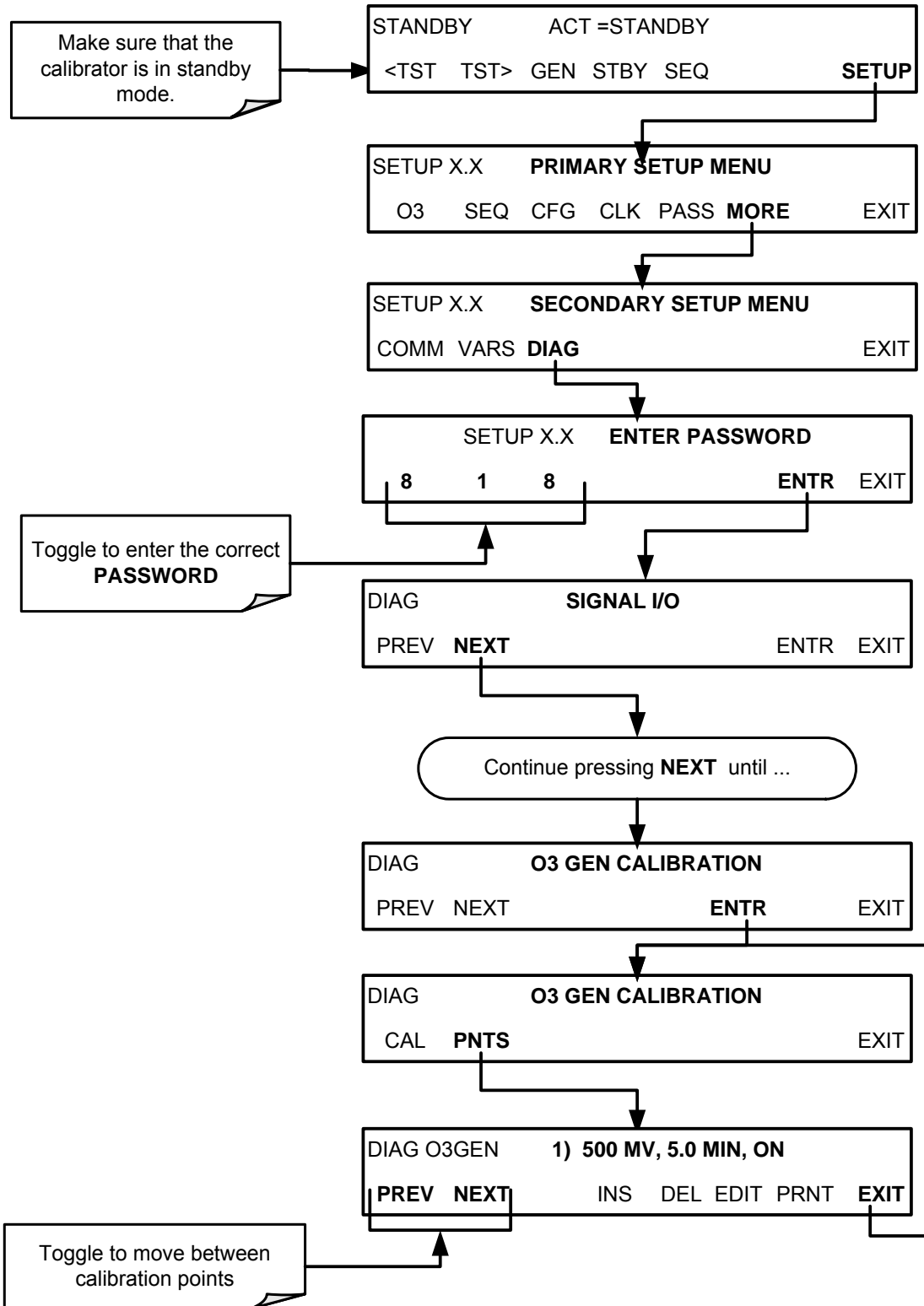

6.2.3. ADDING OR EDITING O₃ GENERATOR CALIBRATION POINTS

To add a calibration point to the table or edit an existing point, press:

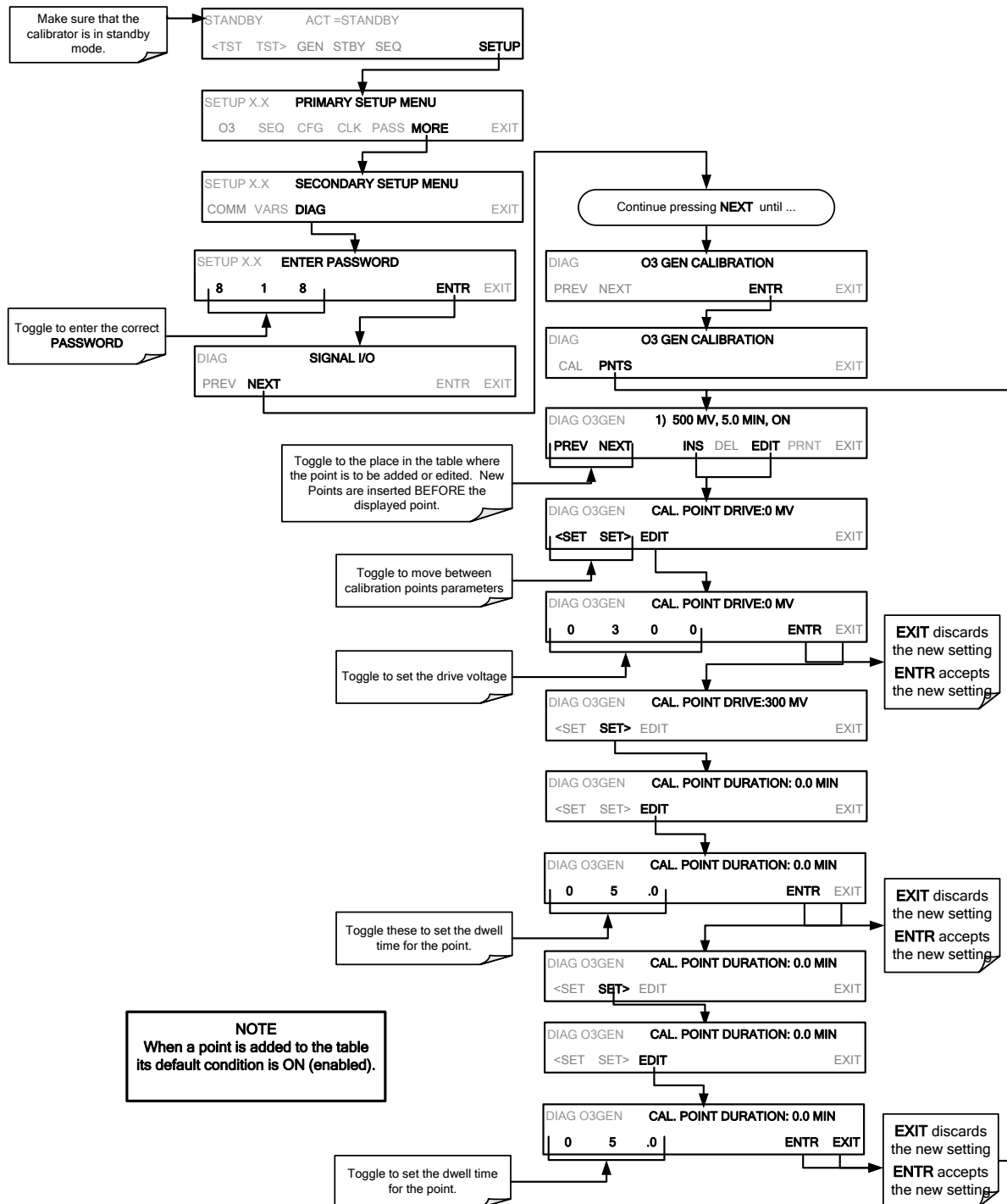

6.2.4. DELETING O₃ GENERATOR CALIBRATION POINTS

To delete an existing calibration point, press:

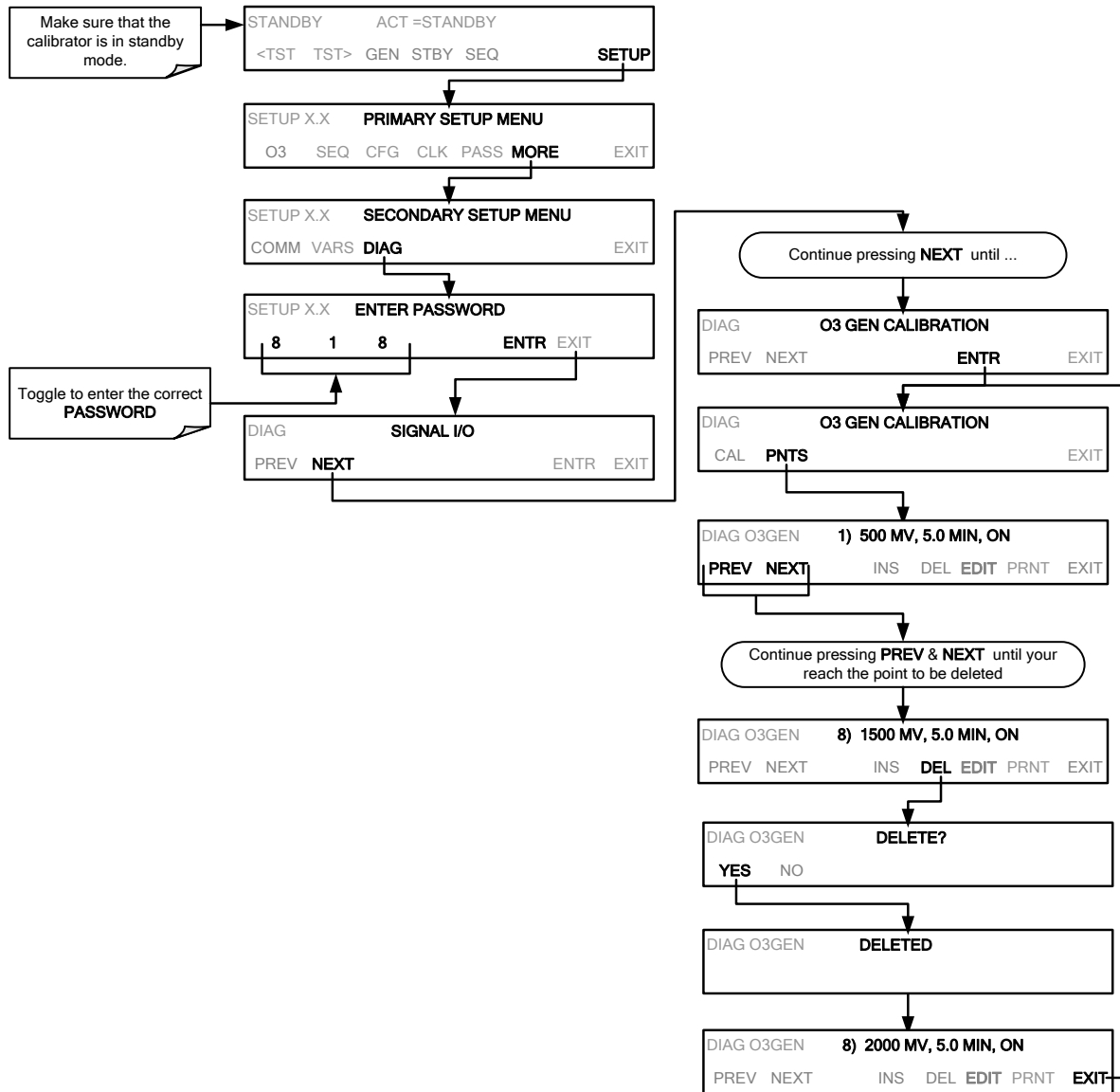

6.2.5. TURNING O₃ GENERATOR CALIBRATION POINTS ON / OFF

To enable or disable an existing calibration point, press:

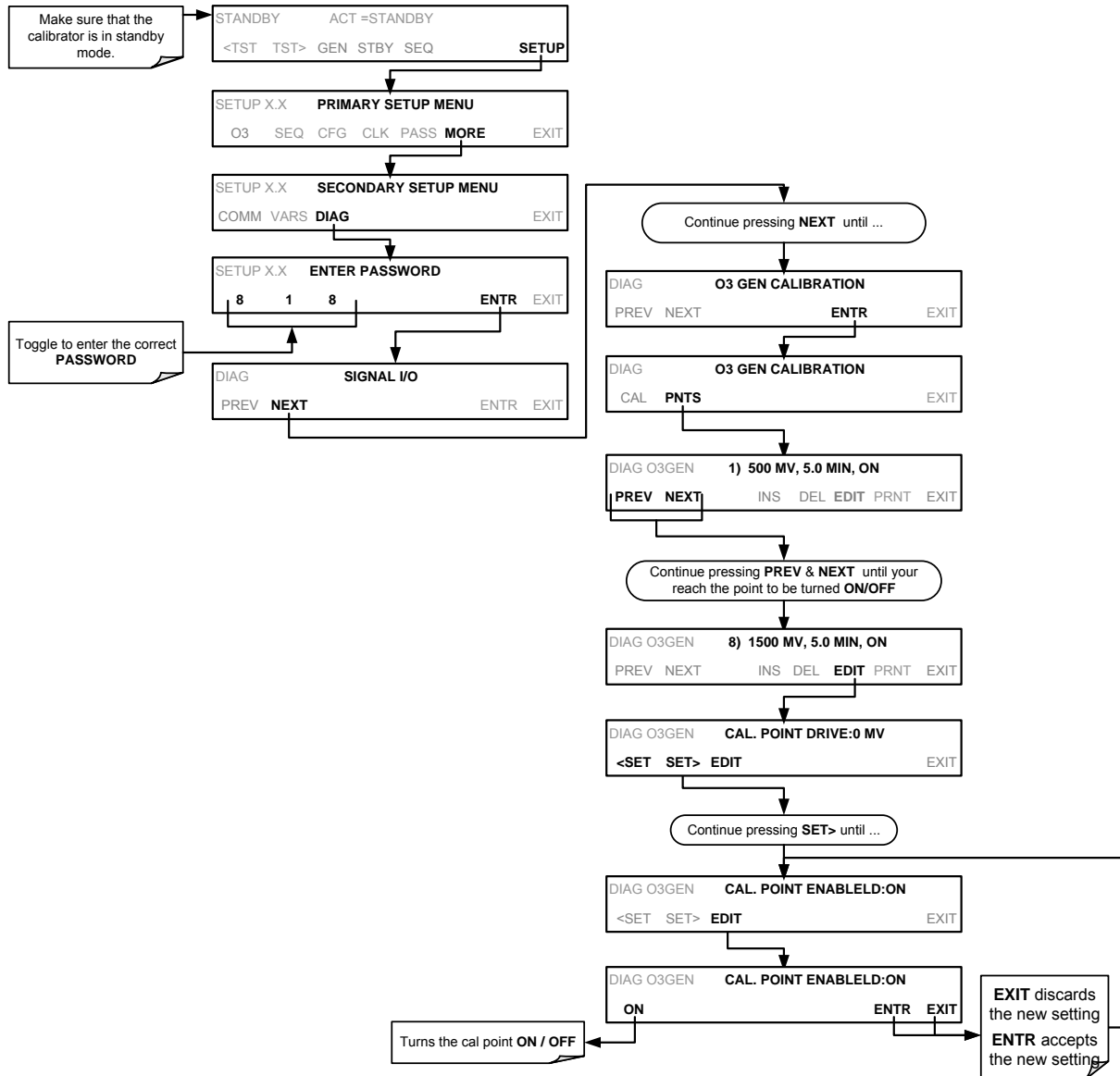

6.2.6. PERFORMING AN AUTOMATIC CALIBRATION OF THE O₃ GENERATOR

To run the automatic O₃ generator calibration program, press:

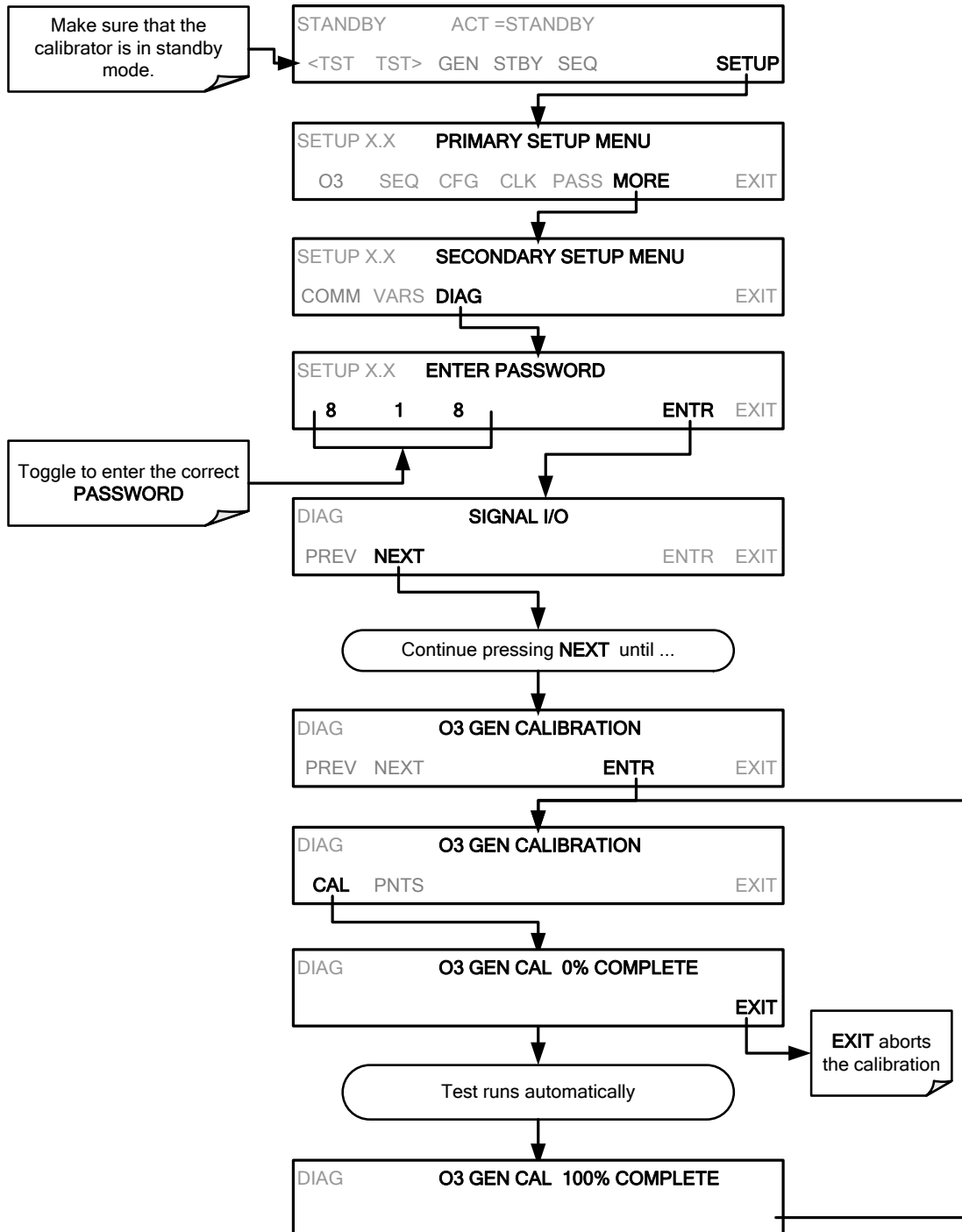

6.3. CALIBRATING GAS PRESSURE SENSORS

The T703 Calibrator has two sensors that monitor the pressure of the gases flowing through the instrument: a Regulator pressure sensor and a Photometer Sample Gas pressure sensor. The T703U also has those two sensors plus one more: an O₃ Generator Regulator pressure sensor. The data collected by these sensors are used to compensate the final concentration calculations for changes in atmospheric pressure and are stored in the CPU's memory as test functions:

Table 6-1: T703/T703U Pressure Sensors

SENSOR	ASSOCIATED TEST FUNCTION	UNITS	PRESSURE MONITOR MEASUREMENT POINT
Regulator Pressure Sensor	REG PRESSURE	PSIG	Capped fitting on backside of regulator assembly. See Figure 6-5.
Photometer Sample Gas Pressure Sensor	PHOTO SPRESS	IN-HG-A	Use monitor to measure ambient atmospheric pressure at the calibrator's location.
(T703U only) O ₃ Generator Regulator Pressure Sensor	O3 PRES	PSIG	Capped fitting on O ₃ Generator Regulator assembly. See Figure 6-6.

6.3.1. GAS PRESSURE SENSOR CALIBRATION SET UP

The procedures described in this section require an independent, calibrated pressure meter/monitor to be attached at the location shown in Figure 6-3 for T703, or at the locations shown in Figure 6-4 for T703U.

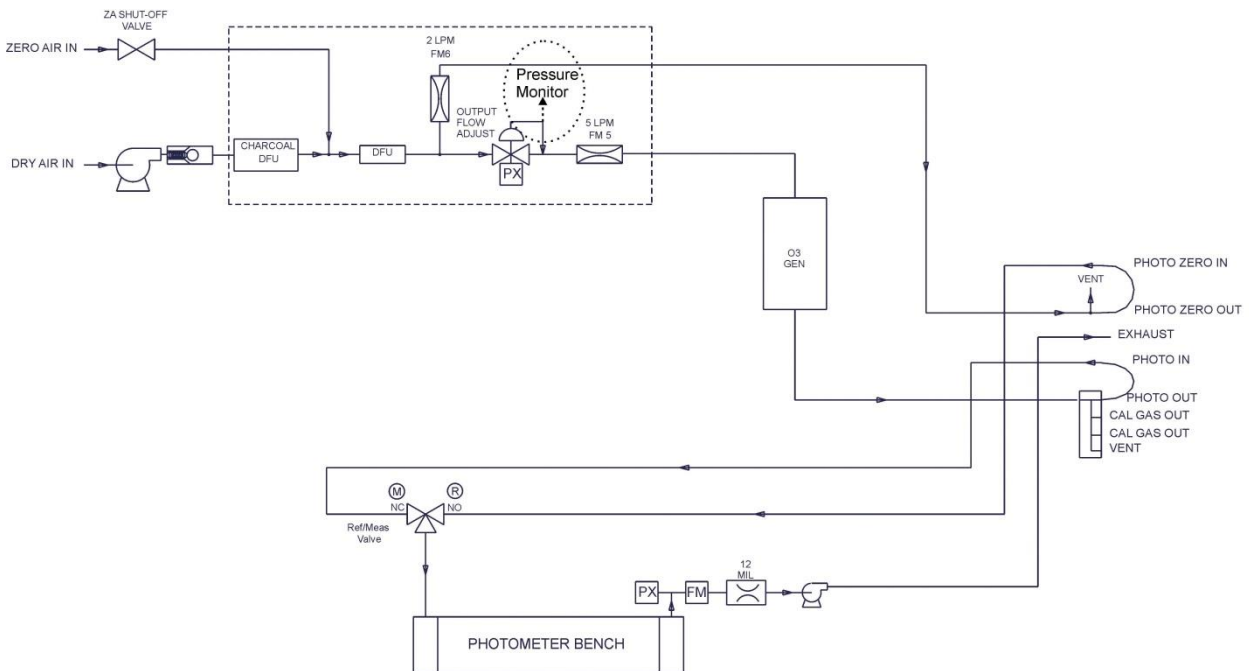

Figure 6-3: Pressure Calibration Monitor Point – T703

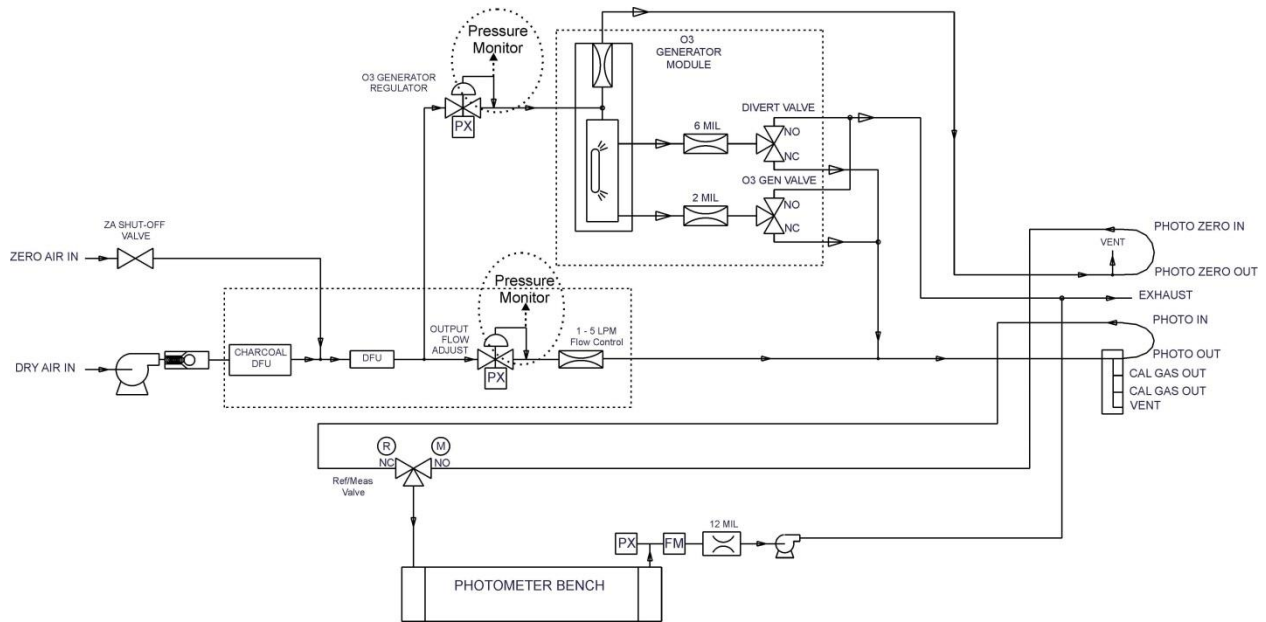

Figure 6-4: Pressure Calibration Monitor Points – T703U

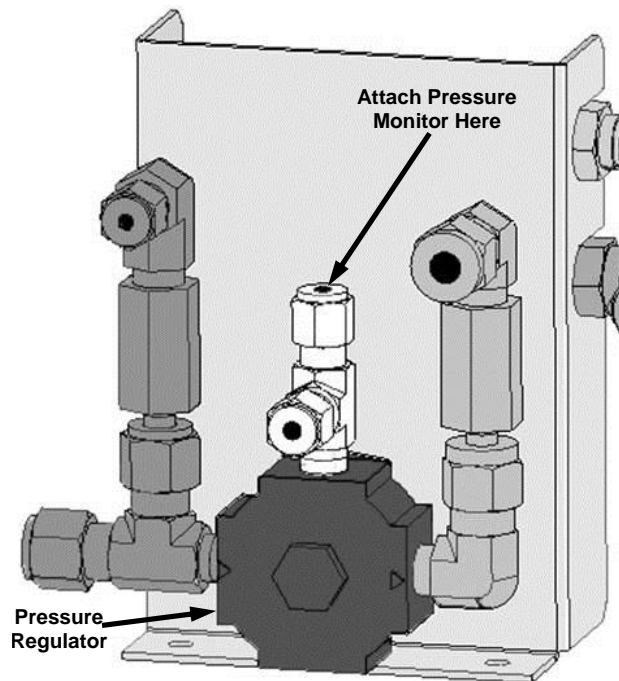

Figure 6-5: Pressure Regulator Monitor Connection Point (T703 and T703U)

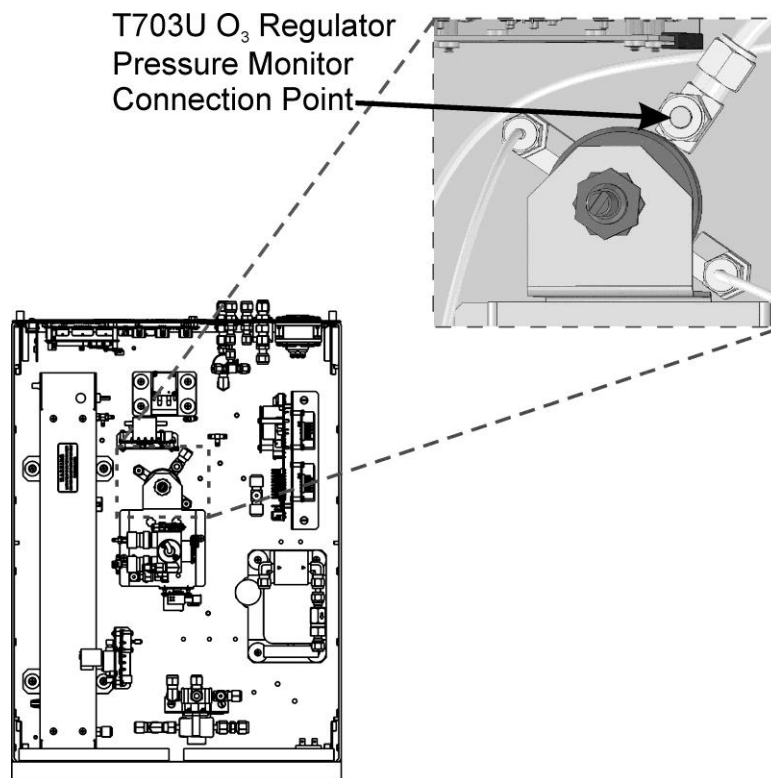
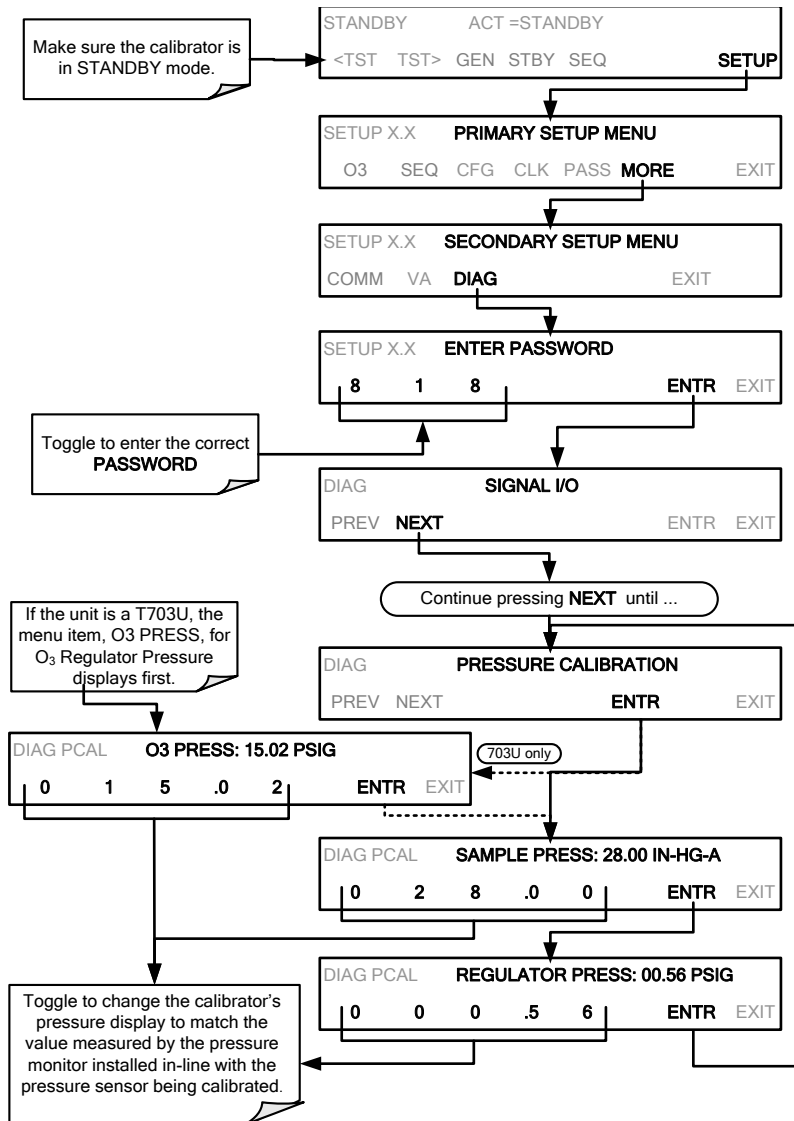

Figure 6-6: O₃ Regulator Pressure Monitor Point (T703U only)

6.3.2. CALIBRATING THE PRESSURE SENSORS

The following procedure requires a pump. If your unit does not have the internal pump option, temporarily connect an external pump.

1. Turn off the calibrator and open the top cover.
2. Connect a pressure meter to the Regulator Pressure measurement fitting (see Figure 6-5). This fitting is located on the backside of the regulator assembly.
3. If the unit is a T703U, also connect a pressure meter to the O₃ Regulator (Figure 6-6).
4. Turn on the calibrator and perform the following steps:



5. Turn OFF the calibrator, remove the pressure monitor, replace the cap on the pressure measurement fitting.

6.4. GAS FLOW CALIBRATION

The T703/T703U has two gas flow characteristics that affect its performance: the flow of gas through the sample chamber of the instrument's photometer and the total gas flow being output. While both are stored in the calibrator's memory and used to compensate the final concentration calculations for changes in atmospheric pressure, they are calculated quite differently:

CALCULATING THE PHOTOMETER SAMPLE GAS FLOW RATE

This flow rate is measured directly by a flow sensor located pressure / flow sensor PCA. A slope factor, stored in the calibrator's memory the last time a **PHOTO FLOW** calibration operation (see Section 6.4.1) was performed, is and applied to the reading from that sensor.

The calculated photometer sample gas flow value is viewable on the instrument's front panel using the **PHOTO FLOW** test function and can be output via the **TEST CHANNEL** output using the **SAMPLE FLOW** function.

CALCULATING THE OUTPUT GAS FLOW RATE

This flow rate is calculated by applying a separate slope factor, also stored in the calibrator's memory, to an interpolated value based on the following table of internal gas pressure as measured by the O₃ gas input pressure sensor. The output-flow slope value is determined by performing an **OUTPUT FLOW** calibration operation (see Section 6.4.2).

Table 6-2: T703/T703U Gas Pressure to Output Flow conversion Table

T703 REGULATOR PRESSURE TO OUTPUT FLOW	
PSIG	LPM
0	0.000
1	0.676
2	1.214
3	1.659
4	2.071
5	2.463
6	2.816
7	3.178
8	3.536
9	3.851
10	4.166
15	5.744
20	7.282
25	8.755
30	10.254
35	11.695
40	13.146

The calculated **OUTPUT FLOW** value is viewable on the instrument's front panel using the **OUTPUT FLOW** test function and can be output via the T703/T703U's **TEST CHANNEL** using the **OUTPUT FLOW** function.

6.4.1. CALIBRATING THE PHOTOMETER'S SAMPLE GAS FLOW

NOTE

The procedure described in this section requires an independent, calibrated gas flow meter/monitor be connected to the EXHAUST fitting on the back of the T703/T703U.

During the **PHOTO FLOW** calibration, the T703/T703U software automatically turns the DC pump downstream from the photometer **ON**. PHOTO FLOW calibration is followed by ACTUAL OUTPUT FLOW (output gas flow) calibration (Section 6.4.2).

To perform a **PHOTO FLOW** calibration, press:

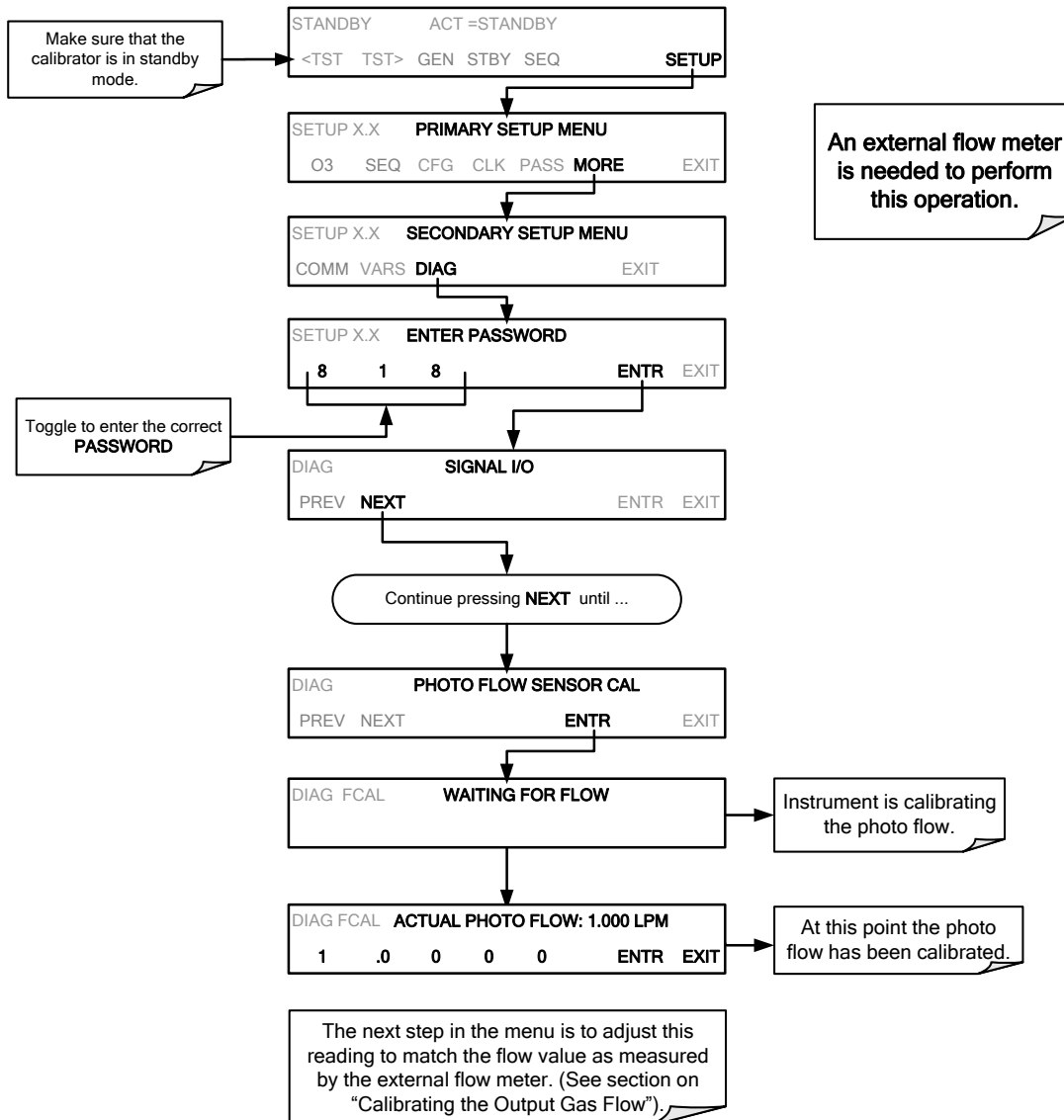

6.4.2. CALIBRATING THE OUTPUT GAS FLOW

6.4.2.1. Output Gas Flow Set Up

The procedure described in this section requires an independent, calibrated flow meter/monitor and the following set up:

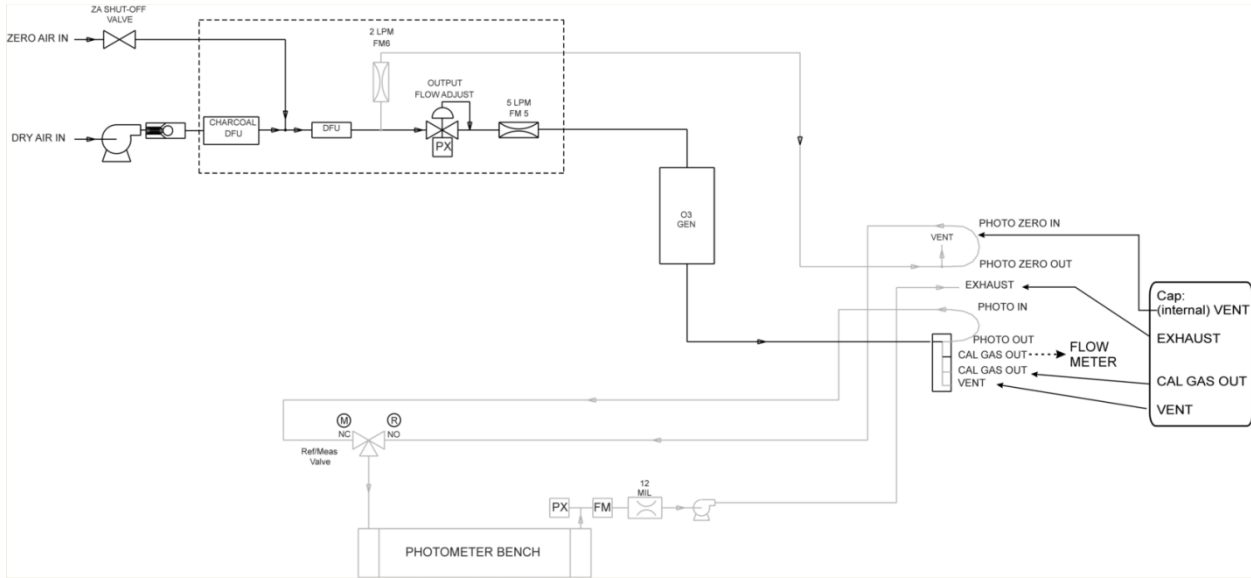

Figure 6-7: Output Flow Calibration Monitor Point – T703

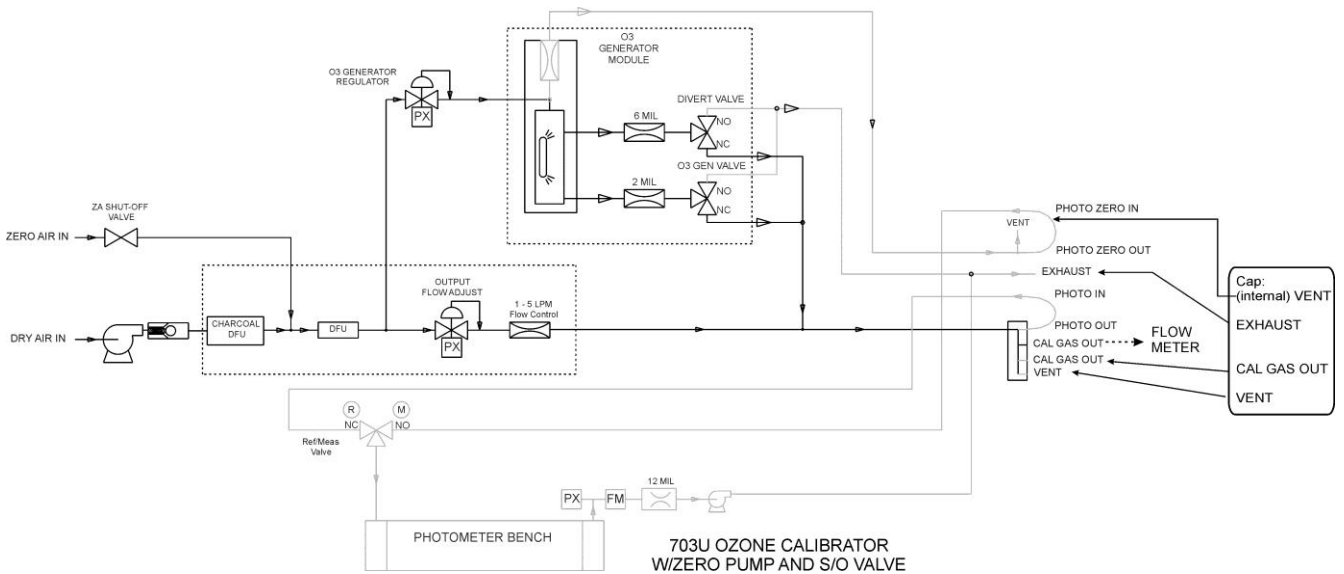
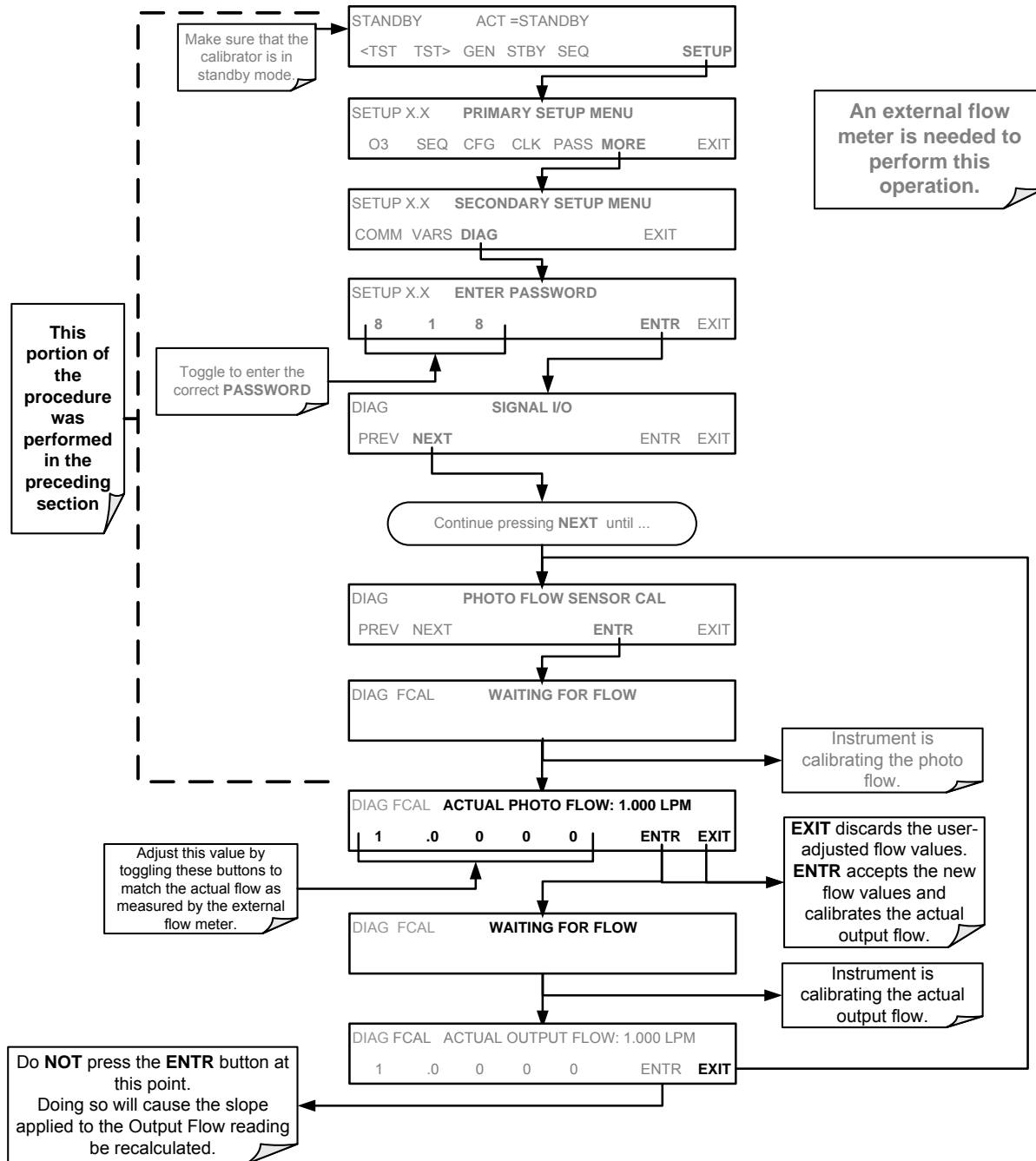

Figure 6-8: Output Flow Calibration Monitor Point – T703U

6.4.2.2. Performing an Output Gas Flow Calibration

During the **PHOTO FLOW** calibration, the T703/T703U software automatically turns the DC pump downstream from the photometer **OFF** and the AC dry air pump **ON**. Once the PHOTO FLOW has been calibrated (Section 8.4.1 – menu sequence included here for continuity), the next step is to adjust the “ACTUAL PHOTO FLOW” values to match the flow measured by the external flow meter in order to calibrate the output gas flow (ACTUAL OUTPUT FLOW), as follows:



7. MAINTENANCE SCHEDULE & PROCEDURES

Predictive diagnostic functions including failure warnings and alarms built into the calibrator's firmware allow the user to determine when repairs are necessary without performing painstaking preventative maintenance procedures.

For the most part, the T703 calibrator is maintenance free, there are, however, a minimal number of simple procedures that when performed regularly will ensure that the T703 photometer continues to operate accurately and reliably over its the lifetime.

Repairs and troubleshooting are covered in Section 8 of this manual.

7.1. MAINTENANCE SCHEDULE

Table 7-1 below shows the recommended maintenance schedule for the T703. Please note that in certain environments (i.e. dusty, very high ambient pollutant levels) some maintenance procedures may need to be performed more often than shown.

NOTE

A Span and Zero Calibration Check (see CAL CHECK REQ'D Column of Table 7-1) must be performed following certain of the maintenance procedure listed below.

See Section 6.1 for instructions on performing a calibration check.

	CAUTION
	RISK OF ELECTRICAL SHOCK. DISCONNECT POWER BEFORE PERFORMING ANY OF THE FOLLOWING OPERATIONS THAT REQUIRE ENTRY INTO THE INTERIOR OF THE INSTRUMENT.

	NOTE
	THE OPERATIONS OUTLINED IN THIS CHAPTER ARE TO BE PERFORMED BY QUALIFIED MAINTENANCE PERSONNEL ONLY.

This page intentionally left blank.

Table 7-1: T703 Maintenance Schedule

Item	Action	Freq	Cal Check Req'd.	Manual Section	Date Performed									
Verify Test Functions	Record and analyze	Weekly or after any Maintenance or Repair	No	3.4.4										
Photometer Pump Diaphragm	No Replacement Required. Under Normal Circumstances the Pumps Will Last the Lifetime of the Instrument.													
Dry Air Pump Diaphragm	Replace	Annually	Yes	7.4										
Absorption Tube	Inspect --- Clean	As Needed	Yes after cleaning	7.3	Cleaning of the Photometer Absorption Tube Should Not Be Required as long as ONLY CLEAN, DRY, PARTICULATE FREE Zero Air (Diluent Gas) is used with the T703 Calibrator									
Perform Leak Check	Verify Leak Tight	Annually or after any Maintenance or Repair	NO	7.2.1										
Pneumatic lines	Examine and clean	As needed	Yes if cleaned	---										

This page intentionally left blank.

7.2. PERFORMING LEAK CHECKS

Leaks are the most common cause of instrument malfunction; Section 7.2.1 describes a procedure for performing a leak check.

7.2.1. PRESSURE LEAK CHECK

The following pressure leak check instructions can be used with either a leak checker (similar to the Teledyne API's part number 01960, which contains a small pump, shut-off valve and pressure gauge) or a tank of pressurized gas, with the two-stage regulator adjusted to ≤ 15 psi, a shutoff valve and pressure gauge may be used.



CAUTION

Once the fittings have been wetted with soap solution, do not apply a vacuum as this will cause soap solution to be drawn into the instrument, contaminating it.

DO NOT EXCEED 15 PSI PRESSURE.

1. Turn OFF power to the calibrator.
2. Remove the instrument cover
3. Install a leak checker or tank of gas as described above on the "DRY AIR IN" port at the rear panel.
4. Install caps on the Internal Vent and on the following rear panel fittings:
 - Exhaust
 - Vent
 - Zero Air In
 - Both CALGAS OUT fittings

Due to normal internal leakage that occurs with pumps, they will need to be bypassed for the leak check:

5. Locate the dry air pump.
6. Disconnect the two fittings on the dry air pump and install a union fitting in place of the pump.
7. Locate the photometer pump.
8. Disconnect the two fittings on the photometer pump and install a union fitting in place of the pump.
9. Pressurize the calibrator with the leak checker or with the tank – *without exceeding 15 psi pressure*, allowing enough time to pressurize the instrument fully.
10. Check each fitting with soap bubble solution, and look for bubbles (*do not reapply vacuum as doing so will draw soap solution into the instrument and contaminate it*).
11. Once the leak has been located and repaired, remove any residual soap solution from the instrument interior with a clean, absorbent cloth.

The leak-down rate should be < 1 in-Hg (0.4 psi) in 5 minutes after the pressure is shut off.

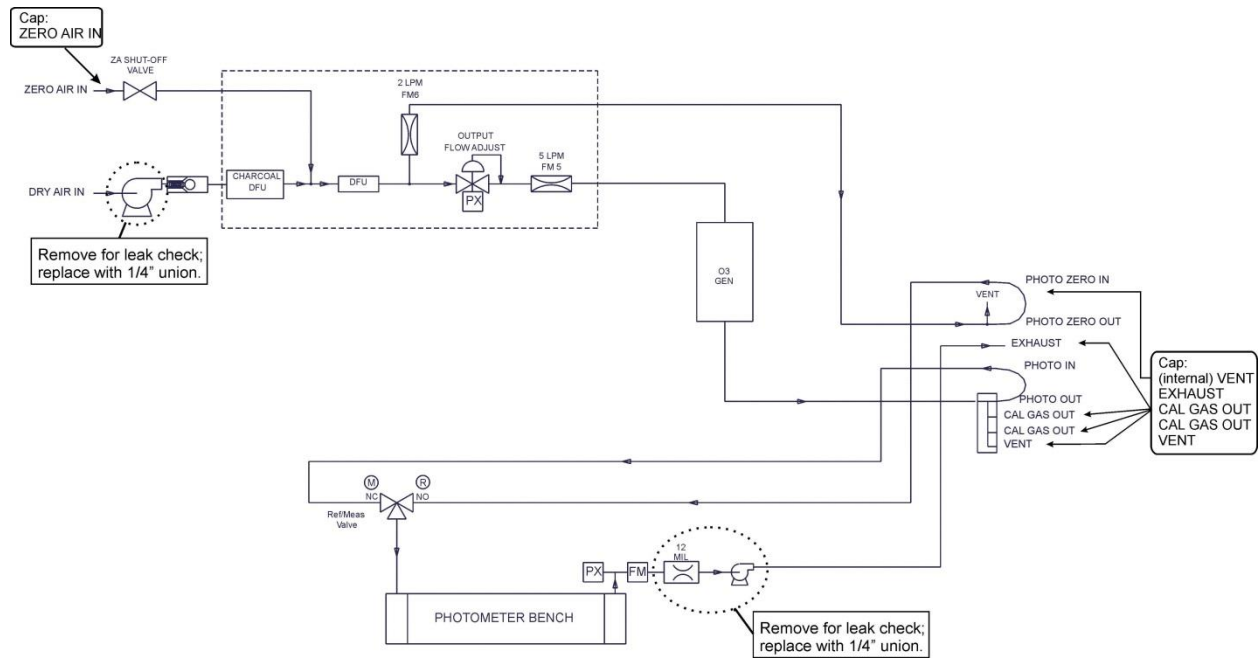

Figure 7-1: T703 Pneumatic setup for performing Pressure Leak Checks

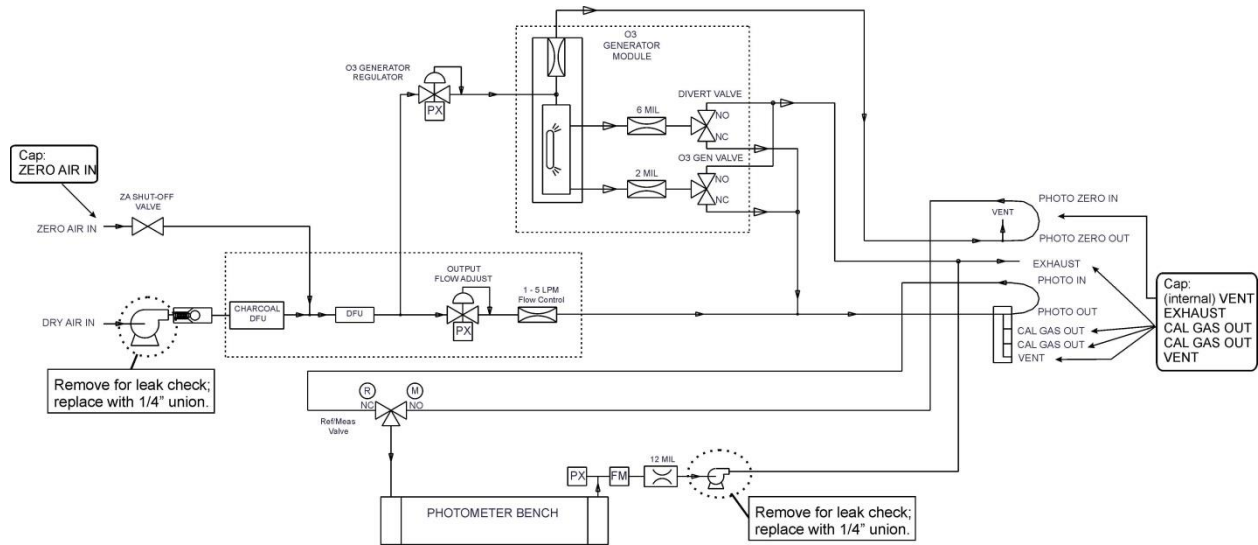

Figure 7-2: T703U Pneumatic Setup for Performing Pressure Leak Checks

7.3. CLEANING OR REPLACING THE ABSORPTION TUBE

NOTE:

Although this procedure should never be needed as long as the user is careful only to supply the photometer with clean, dry and particulate free zero air, it is included here for those rare occasions when cleaning or replacing the absorption tube may be required.

1. Remove the center cover from the optical bench.
2. Unclip the sample thermistor from the tube.
3. Loosen the two screws on the round tube retainers at either end of the tube.
4. Using both hands, carefully rotate the tube to free it.
5. Slide the tube towards the lamp housing.
 - The front of the tube can now be slid past the detector block and out of the instrument.

**CAUTION**

DO NOT CAUSE THE TUBE TO BIND AGAINST THE METAL HOUSINGS. THE TUBE MAY BREAK AND CAUSE SERIOUS INJURY.

6. Clean the tube with Distilled or de-ionized water by running a swab from end-to-end.
7. Air-dry the tube.
8. Check the cleaning job by looking down the bore of the tube.
 - It should be free from dirt and lint.
9. Inspect the o-rings that seal the ends of the optical tube (these o-rings may stay seated in the manifolds when the tube is removed.)
 - If there is any noticeable damage to these o-rings, they should be replaced.
10. Re-assemble the tube into the lamp housing and perform an **AUTO LEAK CHECK** on the instrument.

NOTE:

It is important for proper optical alignment that the tube be pushed all the way towards the front of the optical bench when it is re-assembled.

This will ensure that the tube is assembled with the forward end against the stop inside the detector manifold.

7.4. REBUILDING THE DRY AIR PUMP

The diaphragm in the sample pump will periodically wear out and require replacement. A sample rebuild kit is available. See Appendix B of this manual for the part number of the pump rebuild kit. Instructions and diagrams are included with the kit.

Always perform a Flow and Leak Check after rebuilding the Sample Pump.

7.5. PHOTOMETER UV SOURCE LAMP ADJUSTMENT

This procedure details the steps for adjustment of the UV source lamp in the optical bench assembly. This procedure should be done whenever the **PHOTO REFERENCE** test function value drops below 3000 mV.

1. Make sure the instrument is warmed-up and has been running for at least 15 minutes before proceeding.
2. Remove the cover from the instrument.
3. Locate the Photometer (see Figure 3-5)
4. Locate the **UV DETECTOR GAIN ADJUST POT** on the photometer assembly (see Figure 7-3).
5. Perform the following procedure:

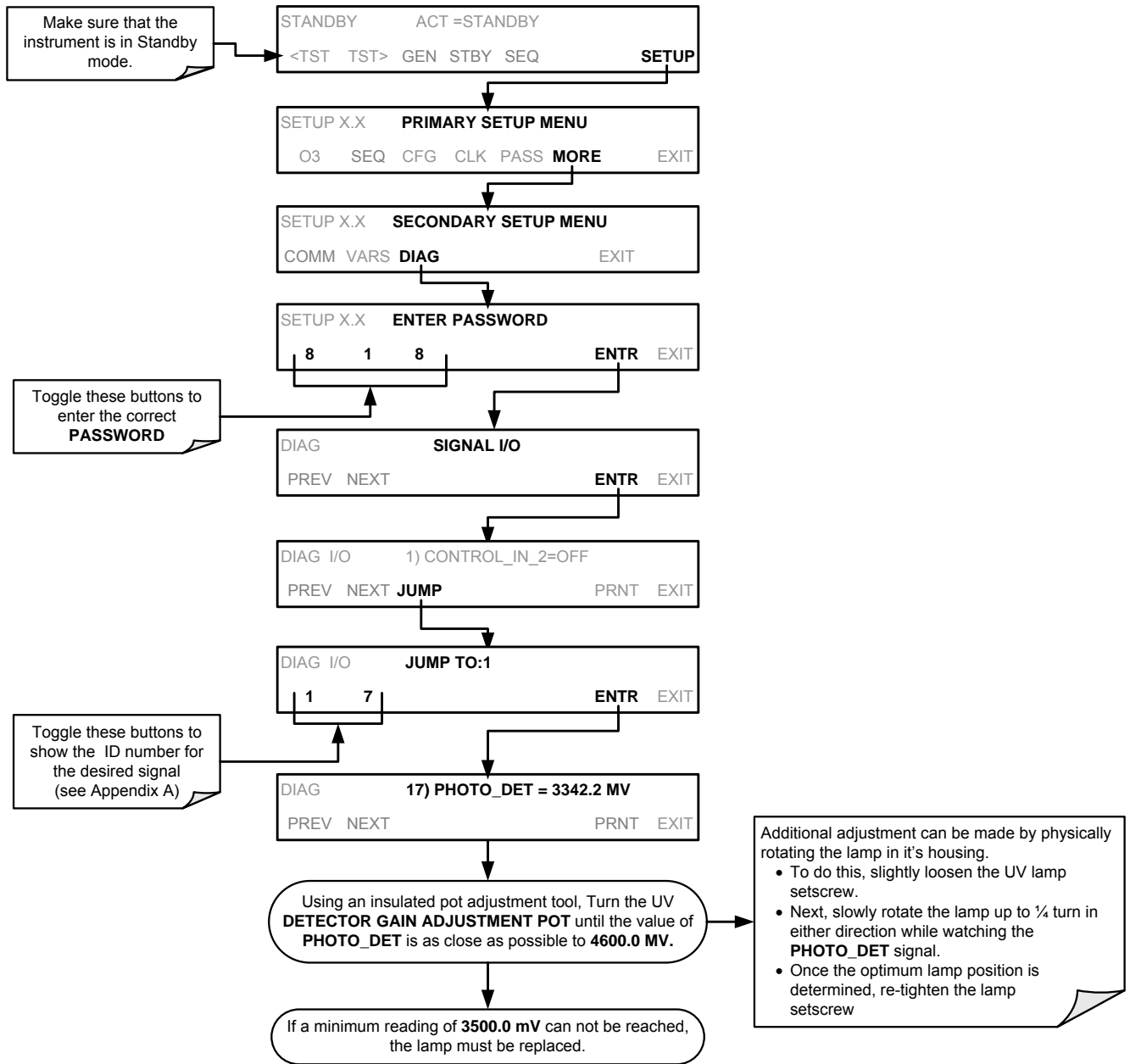

6. Replace the cover on the instrument.

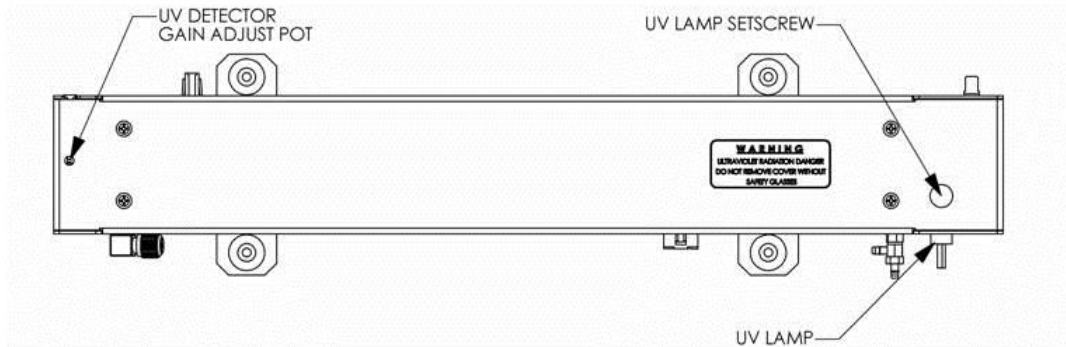

Figure 7-3: Photometer – Location of UV Detector Gain Adjustment & UV Lamp Set Screw

7.6. PHOTOMETER UV SOURCE LAMP REPLACEMENT

This procedure details the steps for replacement of the UV source lamp in the optical bench assembly. This procedure should be done whenever the lamp can no longer be adjusted as described in Section 10.2.3.

1. Turn the instrument off.
2. Remove the cover from the instrument.
3. Locate the Optical Bench Assembly (see Figure 3-5)
4. Locate the UV lamp at the rear of the optical bench assembly (see Figure 7-3)
5. Unplug the lamp cable from the power supply connector on the side of the optical bench.
6. Slightly loosen (do not remove) the UV lamp setscrew and pull the lamp from its housing.

NOTE

The UV lamp contains mercury (Hg), which is considered hazardous waste. The lamp should be disposed of in accordance with local regulations regarding waste containing mercury.

7. Install the new lamp in the housing, pushing it all the way in. Leave the UV lamp setscrew loose for now.
8. Turn the instrument back on and allow it to warm up for at least 15 minutes.
9. Turn the UV detector gain adjustment pot (See Figure 7-3) clockwise to its minimum value. The pot should click softly when the limit is reached.
10. Perform the UV Lamp Adjustment procedure described in Section 7.5, with the following exceptions:
11. Slowly rotate the lamp in its housing (up to $\frac{1}{4}$ turn in either direction) until a **MAXIMUM** value (or 4600 mVDC) is observed.
 - Make sure the lamp is pushed all the way into the housing while performing this rotation.
 - If the PHOTO_DET will not drop below 5000 mV while performing this rotation, contact TAPI Technical Support for assistance.

12. Once a lamp position is found that corresponds to a maximum observed value for **PHOTO_DET**, tighten the lamp setscrew at the approximate maximum value observed.
 - If the value of **PHOTO_DET** is not within the range of 4400 – 4600 mV, adjust it accordingly.
13. Replace the cover on the instrument.

7.7. ADJUSTMENT OR REPLACEMENT OF OZONE GENERATOR UV LAMP

This procedure details the steps for replacement and initial adjustment of the ozone generator lamp. If you are adjusting an existing lamp, skip to Step 8.

1. Turn off the instrument.
2. Remove the cover from the instrument.
3. Locate the O₃ generator (see Figure 3-5).

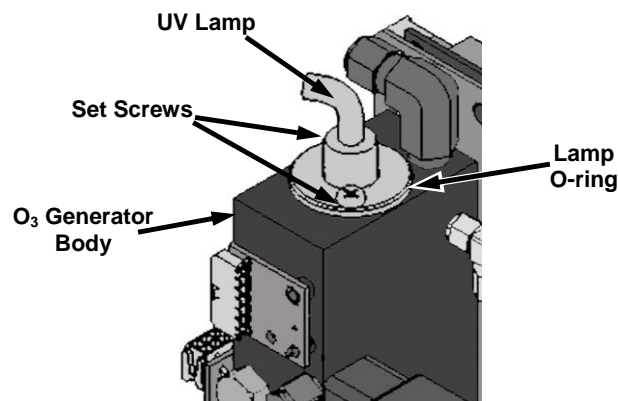

Figure 7-4: O₃ Generator Temperature Thermistor and DC Heater Locations

4. Remove the two setscrews on the top of the O₃ generator and gently pull out the old lamp.
5. Inspect the o-ring beneath the nut and replace if damaged.
6. Install the new lamp in O₃ generator housing, ensuring that it is fully seated.
 -
7. Tighten the two set screws.
8. Turn on instrument and allow it to stabilize for at least 30 minutes.
9. Replace the calibrator's cover
10. Perform an auto-leak check (See Section 10.2.1).
11. Calibrate the Ozone Generator. (see Section 6.2)

This page intentionally left blank.

8. GENERAL TROUBLESHOOTING & SERVICE

This section contains a variety of methods for identifying and solving performance problems with the calibrator.



NOTE

The operations outlined in this chapter must be performed by qualified maintenance personnel only.



WARNING

- Risk of electrical shock. Some operations need to be carried out with the instrument open and running.
- Exercise caution to avoid electrical shocks and electrostatic or mechanical damage to the calibrator.
- Do not drop tools into the calibrator or leave those after your procedures.
- Do not shorten or touch electric connections with metallic tools while operating inside the calibrator.
- Use common sense when operating inside a running calibrator.

8.1. GENERAL TROUBLESHOOTING

The T703 Photometric Calibrator has been designed so that problems can be rapidly detected, evaluated and repaired. During operation, it continuously performs diagnostic tests and provides the ability to evaluate its key operating parameters without disturbing monitoring operations.

A systematic approach to troubleshooting will generally consist of the following five steps:

1. Note any warning messages and take corrective action as necessary.
2. Examine the values of all TEST functions and compare them to factory values. Note any major deviations from the factory values and take corrective action.
3. Use the internal electronic status LEDs to determine whether the electronic communication channels are operating properly.
 - Verify that the DC power supplies are operating properly by checking the voltage test points on the relay PCA.
 - Note that the calibrator's DC power wiring is color-coded and these colors match the color of the corresponding test points on the relay PCA.
4. Suspect a leak first!
 - Technical Support data indicate that the majority of all problems are eventually traced to leaks in the internal pneumatics of the calibrator or the diluent gas and source gases delivery systems.
 - Check for gas flow problems such as clogged or blocked internal/external gas lines, damaged seals, punctured gas lines, a damaged / malfunctioning pumps, etc.

5. Follow the procedures defined in Section 3.4.4 to confirm that the calibrator's vital functions are working (power supplies, CPU, relay PCA, keyboard, PMT cooler, etc.).
 - See Figure 3-5 for general layout of components and sub-assemblies in the calibrator.
 - See the wiring interconnect diagram and interconnect list in Appendix D.

8.1.1. FAULT DIAGNOSIS WITH WARNING MESSAGES

The most common and/or serious instrument failures will result in a warning message being displayed on the front panel. Table 8-1 lists warning messages, along with their meaning and recommended corrective action.

It should be noted that more than two or three warning messages occurring at the same time is often an indication that some fundamental sub-system (power supply, relay PCA, motherboard) has failed rather than an indication of the specific failures referenced by the warnings. In this case, it is recommended that proper operation of power supplies (See Section 8.4.3), the relay PCA (See Section 8.4.7), and the motherboard (See Section 8.4.9) be confirmed before addressing the specific warning messages.

If a Warning Message is active, the FAULT LED flashes, the Param field displays the Warning message, and the **CLR** button appears/becomes active (press to clear Warning message). However, if there is more than one warning in queue or if you are in the TEST menu and have not yet cleared the message, the **MSG** button displays. The following display/touchscreen examples provide an illustration of each:



Top: the CLR button is available to clear the warning message displayed in the Param field.

Bottom: the MSG button indicates that at least one warning message has not yet been cleared.

The calibrator also alerts the user via the Serial I/O COM port(s) and causes the FAULT LED on the front panel to blink.

To view or clear the various warning messages press:

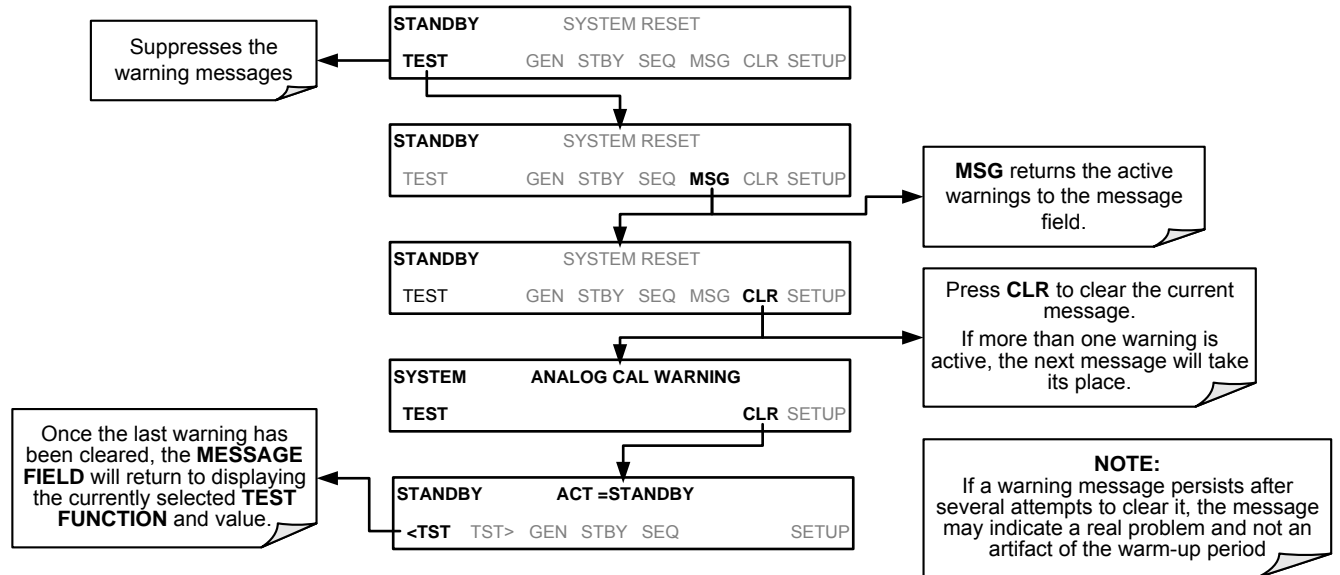

Table 8-1: Front Panel Warning Messages

WARNING	FAULT CONDITION	POSSIBLE CAUSES
CONFIG INITIALIZED	Configuration and Calibration data reset to original Factory state.	<ul style="list-style-type: none"> - Failed Disk on Chip - User has erased configuration data
DATA INITIALIZED	Data Storage in DAS was erased.	<ul style="list-style-type: none"> - Failed Disk-on-Module. - User cleared data.
LAMP DRIVER WARN	The CPU is unable to communicate with either the O ₃ generator or photometer lamp I ² C driver chip.	<ul style="list-style-type: none"> - I²C has failed
O3 GEN LAMP TEMP WARNING	IZS Ozone Generator Temp is outside of control range of 48°C ± 3°C.	<ul style="list-style-type: none"> - No IZS option installed, instrument improperly configured - O₃ generator heater - O₃ generator temperature sensor - Relay controlling the O₃ generator heater - Entire Relay PCA - I²C Bus
O3 PUMP WARNING¹	The photometer pump failed to turn on within the specified timeout period (default = 30 sec.).	<ul style="list-style-type: none"> - Failed Pump - Problem with Relay PCA - 12 VDC power supply problem
PHOTO LAMP TEMP WARNING	The photometer lamp temp is < 51°C or >61°C.	Possible failure of: <ul style="list-style-type: none"> - Bench lamp heater - Bench lamp temperature sensor - Relay controlling the bench heater - Entire Relay PCA - I²C Bus - Hot Lamp
PHOTO LAMP STABILITY WARNING	Value output during the Photometer's reference cycle changes from measurement to measurement more than 25% of the time.	<ul style="list-style-type: none"> - Faulty UV source lamp - Noisy UV detector - Faulty UV lamp power supply - Faulty ± 15 VDC power supply

WARNING	FAULT CONDITION	POSSIBLE CAUSES
PHOTO REFERENCE WARNING	Occurs when Ref is <2500 mVDC or >4950 mVDC.	Possible failure of: <ul style="list-style-type: none"> - UV Lamp - UV Photo-Detector Preamp
REAR BOARD NOT DET	Motherboard not detected on power up.	<ul style="list-style-type: none"> - THIS WARNING only appears on Serial I/O COM Port(s) Front Panel Display will be frozen, blank or will not respond. - Failure of Motherboard
RELAY BOARD WARN	The CPU cannot communicate with the Relay PCA.	<ul style="list-style-type: none"> - I²C Bus failure - Failed relay PCA - Loose connectors/wiring
SYSTEM RESET	The computer has rebooted.	<ul style="list-style-type: none"> - This message occurs at power on. - If it is confirmed that power has not been interrupted: <ul style="list-style-type: none"> - Failed +5 VDC power - Fatal error caused software to restart - Loose connector/wiring

8.1.2. FAULT DIAGNOSIS WITH TEST FUNCTIONS

In addition to being useful predictive diagnostic tools, the test functions viewable from the calibrator's front panel can be used to isolate and identify many operational problems when combined with a thorough understanding of the calibrator's Theory of Operation (see Section 9).

The acceptable ranges for these test functions are listed in the "Nominal Range" column of the calibrator Final Test and Validation Data Sheet shipped with the instrument. Values outside these acceptable ranges indicate a failure of one or more of the calibrator's subsystems. Functions whose values are still within the acceptable range but have significantly changed from the measurement recorded on the factory data sheet may also indicate a failure.

A worksheet has been provided in Appendix C to assist in recording the value of these Test Functions.

Table 8-2 contains some of the more common causes for these values to be out of range.

Table 8-2: Test Functions - Indicated Failures

TEST FUNCTION	DIAGNOSTIC RELEVANCE AND CAUSES OF FAULT CONDITIONS.
OUTPUT FLOW	Gas flow problems directly affect the concentration accuracy of the O ₃ calibration gases. This number is computed using data from the calibrator's <ul style="list-style-type: none"> - Check for Gas Flow problems. - Check the pressure regulator
O3 GEN DRIVE	Check the O ₃ generator heater and temperature sensors Possible causes of faults are the same as O3 GEN LAMP TEMP WARNING from Table 8-1
O3 LAMP TEMP	Incorrect Lamp temperature can affect the efficiency and durability of the O ₃ generators UV lamp. Possible causes of faults are the same as O3 GEN LAMP TEMP WARNING from Table 8-1
REG PRESSURE	Same as REGULATOR PRESSURE WARNING from Table 8-1
BOX TEMP	If the Box Temperature is out of range, make sure that the: Box Temperature typically runs ~7°C warmer than ambient temperature. <ul style="list-style-type: none"> - The Exhaust-Fan is running

TEST FUNCTION	DIAGNOSTIC RELEVANCE AND CAUSES OF FAULT CONDITIONS.
	<ul style="list-style-type: none"> - The there is sufficient open space to the side and rear of instrument to allow adequate ventilation.
<p>PHOTO MEASURE & PHOTO REFERENCE</p>	<p>If the value displayed is too high the UV Source has become brighter. Adjust the variable gain potentiometer on the UV Preamp Board in the optical bench.</p> <p>If the value displayed is too low:</p> <ul style="list-style-type: none"> - < 100mV – Bad UV lamp or UV lamp power supply. - < 2000mV – Lamp output has dropped, adjust UV Preamp Board or replace lamp. <p>If the value displayed is constantly changing:</p> <ul style="list-style-type: none"> - Bad UV lamp. - Defective UV lamp power supply. - Failed I²C Bus. <p>If the PHOTO REFERENCE value changes by more than 10mV between zero and span gas:</p> <ul style="list-style-type: none"> - Defective/leaking switching valve.
<p>PHOTO FLOW</p>	<p>Gas flow problems directly affect the accuracy of the photometer measurements and therefore the concentration accuracy of cal gas mixtures involving O₃ and GPT mixtures.</p> <ul style="list-style-type: none"> - Check for Gas Flow problems.
<p>PHOTO LAMP TEMP</p>	<p>Poor photometer temp control can cause instrument noise, stability and drift. Temperatures outside of the specified range or oscillating temperatures are cause for concern. Possible causes of faults are the same as PHOTO LAMP TEMP WARNING from Table 8-1</p>
<p>PHOTO SPRESS</p>	<p>The pressure of the gas in the photometer's sample chamber is used to calculate the concentration of O₃ in the gas stream. Incorrect sample pressure can cause inaccurate readings.</p> <ul style="list-style-type: none"> - Check for Gas Flow problems. See Section Table 8-1.
<p>PHOTO STEMP</p>	<p>The temperature of the gas in the photometer's sample chamber is used to calculate the concentration of O₃ in the gas stream. Incorrect sample temperature can cause inaccurate readings.</p> <p>Possible causes of faults are:</p> <ul style="list-style-type: none"> - Bad bench lamp heater - Failed sample temperature sensor - Failed relay controlling the bench heater - Failed Relay PCA - I²C Bus malfunction - Hot Lamp
<p>PHOTO SLOPE</p>	<p>Values outside range indicate:</p> <p>Contamination of the Zero Air or Span Gas supply.</p> <p>Instrument is miss-calibrated.</p> <p>Blocked Gas Flow.</p> <p>Faulty Sample Pressure Sensor or circuitry.</p> <p>Bad/incorrect Span Gas concentration.</p>
<p>PHOTO OFFSET</p>	<p>Values outside range indicate:</p> <p>Contamination of the Zero Air supply.</p>
<p>TIME</p>	<p>Time of Day clock is too fast or slow.</p> <p>To adjust see Section 4.7.2.</p> <p>Battery in clock chip on CPU board may be dead.</p>

8.1.3. USING THE DIAGNOSTIC SIGNAL I/O FUNCTION

The Signal I/O parameters found under the DIAG Menu combined with a thorough understanding of the instruments Theory of Operation (found in Section 9) are useful for troubleshooting in three ways:

- The technician can view the raw, unprocessed signal level of the calibrator's critical inputs and outputs.
- Many of the components and functions that are normally under algorithmic control of the CPU can be manually exercised.
- The technician can directly control the signal level Analog and Digital Output signals.

This allows the technician to observe systematically the effect of directly controlling these signals on the operation of the calibrator. Figure 8-1 is an example of how to use the Signal I/O menu to view the raw voltage of an input signal or to control the state of an output voltage or control signal. The specific parameter will vary depending on the situation.

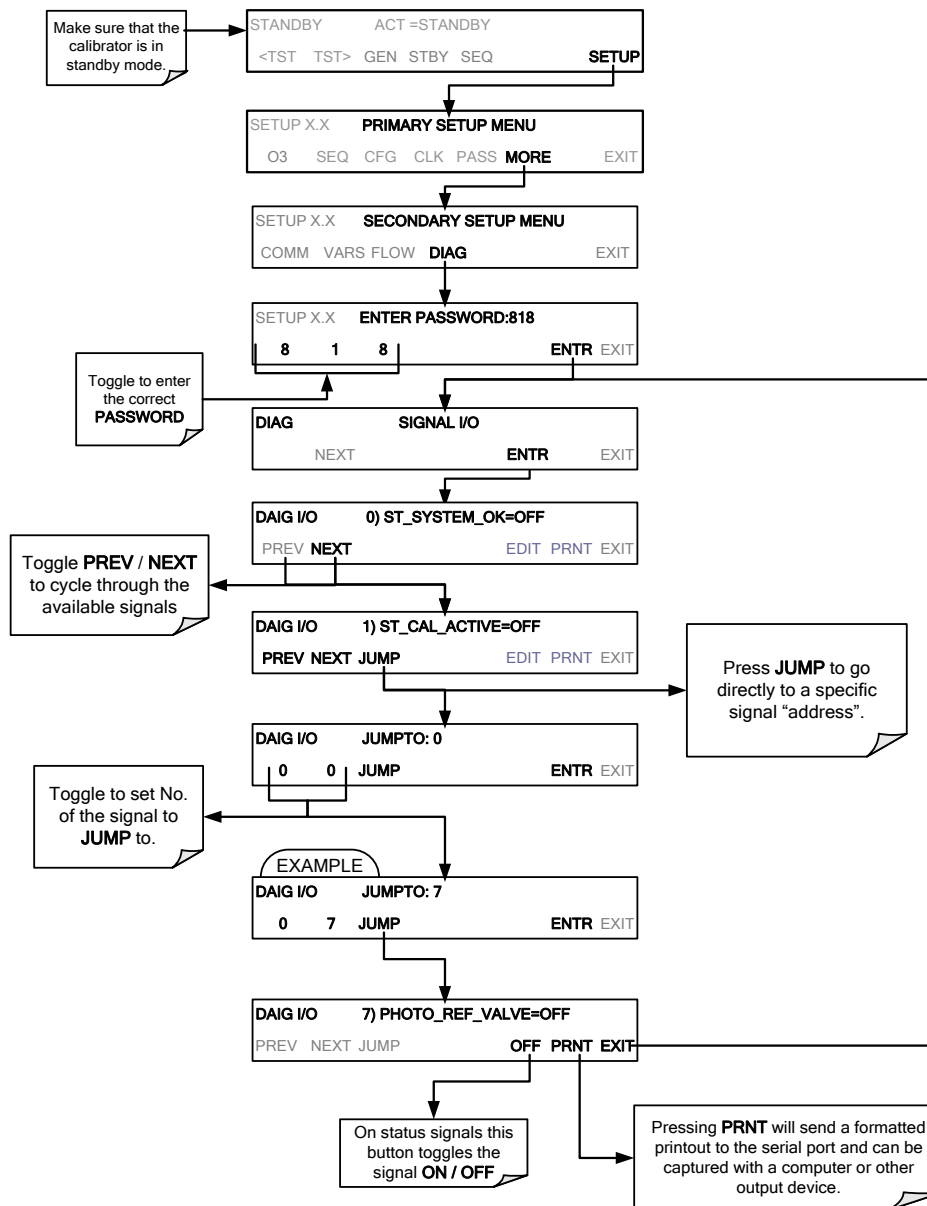

Figure 8-1: Example of Signal I/O Function

8.2. USING THE ANALOG OUTPUT TEST CHANNEL

The signals available for output over the analog output channel can also be used as diagnostic tools. See Section 4.9 for instruction on activating the analog output and selecting a function.

Table 8-3: Test Channel Outputs as Diagnostic Tools

TEST CHANNEL	DESCRIPTION	ZERO	FULL SCALE	CAUSES OF EXTREMELY HIGH / LOW READINGS
NONE	TEST CHANNEL IS TURNED OFF			
O3 PHOTO MEAS	The raw output of the photometer during its measure cycle	0 mV	5000 mV*	<p>If the value displayed is:</p> <ul style="list-style-type: none"> - >5000 mV: The UV source has become brighter. Adjust the UV Detector Gain potentiometer. - < 100mV – Bad UV lamp or UV lamp power supply. - < 2000mV – Lamp output has dropped, adjust UV Preamp Board or replace lamp. <p>If the value displayed is constantly changing:</p> <ul style="list-style-type: none"> - Bad UV lamp. - Defective UV lamp power supply. - Failed I²C Bus.
O3 PHOTO REF	The raw output of the photometer during its reference cycle	0 mV	5000 mV	<p>If the PHOTO REFERENCE value changes by more than 10mV between zero and span gas:</p> <ul style="list-style-type: none"> - Defective/leaking M/R switching valve.
OUTPUT FLOW	Output flow rate (computed from regulator pressure).	0 LPM	6.000 LPM	Possible causes of faults are the same as O3 GEN REFERENCE WARNING from Table 8-1
SAMPLE PRESSURE	The pressure of gas in the photometer absorption tube	0 In-Hg-A	40 In-Hg-A	Check for Gas Flow problems.
SAMPLE FLOW	The gas flow rate through the photometer	0 cm ³ /min	1000 cc/m	Check for Gas Flow problems.
SAMPLE TEMP	The temperature of gas in the photometer absorption tube	0 °C	70 °C	Possible causes of faults are the same as PHOTO STEMP from Table 8-2
PHOTO LAMP TEMP	The temperature of the photometer UV lamp	0 C°C	70 °C	<p>Possible failure of:</p> <ul style="list-style-type: none"> - Bench lamp heater - Bench lamp temperature sensor - Relay controlling the bench heater - Entire Relay PCA - I²C Bus - Hot[®] Lamp
O3 LAMP TEMP	The temperature of the O ₃ generator's UV lamp	0 mV	5000 mV	Same as PHOTO LAMP TEMP WARNING from Table 8-1
CHASSIS TEMP	The temperature inside the chassis (same as BOX TEMP)	0 °C	70 °C	Possible causes of faults are the same as BOX TEMP from Table 8-2
O3 PHOTO CONC	The current concentration of O ₃ being measured by the photometer.		---	<ul style="list-style-type: none"> - I²C Bus malfunction - Gas flow problem through the photometer. - Electronic failure of the photometer subsystems - Failure or pressure / temperature sensors associated with the photometer - Bad/incorrect Span Gas concentration - Contamination of the Zero Air supply. - Malfunction of the O₃ generator. - Internal A/D converter problem

8.3. USING THE INTERNAL ELECTRONIC STATUS LEDES

Several LEDs are located inside the instrument to assist in determining if the calibrators CPU, I²C bus and Relay PCA are functioning properly.

8.3.1. CPU STATUS INDICATOR

DS5, a red LED, that is located on upper portion of the motherboard, just to the right of the CPU board, flashes when the CPU is running the main program loop. After power-up, approximately 30 – 60 seconds, DS5 should flash on and off. If characters are written to the front panel display but DS5 does not flash then the program files have become corrupted, contact Technical Support because it may be possible to recover operation of the calibrator. If after 30 – 60 seconds neither DS5 is flashing and no characters have been written to the front panel display then the CPU is bad and must be replaced.

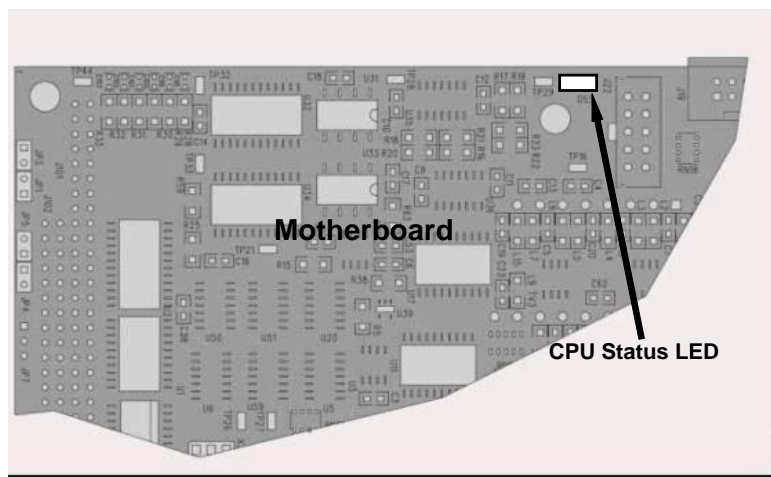

Figure 8-2: CPU Status Indicator

8.3.2. RELAY PCA STATUS LEDES

There are sixteen status LEDs on the Relay PCA. Not all are used on this model.

8.3.2.1. I²C Bus Watchdog Status LEDs

The most important is D1 (see Figure 8-3), which indicates the health of the I²C bus.

Table 8-4: Relay PCA Watchdog LED Failure Indications

LED	Function	Fault Status	Indicated Failure(s)
D1 (Red)	I ² C bus Health (Watchdog Circuit)	Continuously ON or Continuously OFF	Failed/Halted CPU Faulty Motherboard or Relay PCA Faulty Connectors/Wiring between Motherboard or Relay PCA Failed/Faulty +5 VDC Power Supply (PS1)

If D1 is blinking, then the other LEDs can be used in conjunction with **DIAG** Menu Signal I/O to identify hardware failures of the relays and switches on the Relay.

8.3.2.2. Troubleshooting with Relay Board Status LEDs

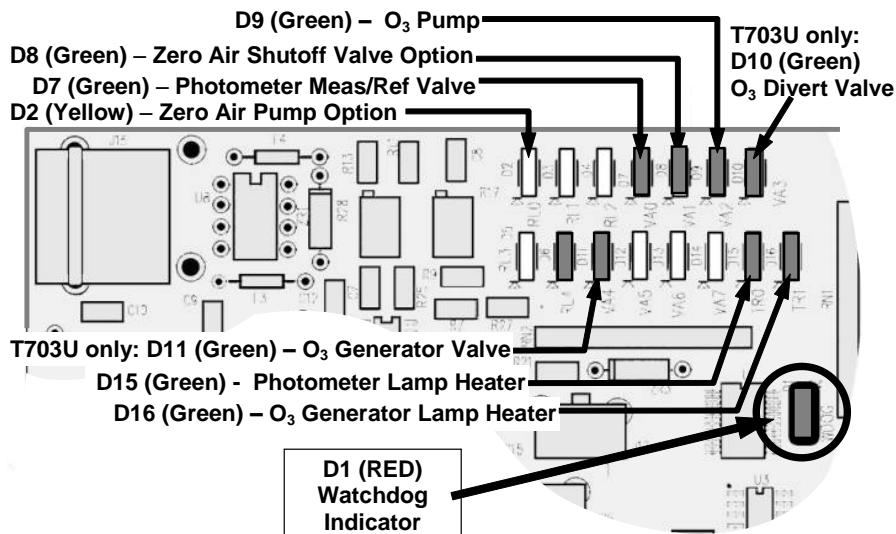

Figure 8-3: Relay PCA Status LEDs Used for Troubleshooting

Table 8-5: Relay PCA Status LED Failure Indications

LED	INDICATES	ACTIVATED BY	DIAGNOSTIC TECHNIQUE
D2 Yellow	AC- powered Zero Air Pump (option) status	ZERO_AIR_PUMP	Pump should start /stop. If not: <ul style="list-style-type: none"> Failed pump Failed AC Relay on Relay PCA Failed Relay PCA Faulty AC Power Supply (PS2) Faulty Connectors/Wiring
D7 Green	Photometer Meas/Ref Valve status	PHOTO_REF_VALVE	Valve should audibly change states. If not: <ul style="list-style-type: none"> Failed Valve Failed Relay Drive IC on Relay PCA Failed Relay PCA Faulty +12 VDC Supply (PS2) Faulty Connectors/Wiring
D8 Green	Zero Air Shutoff Valve (option) status	ZA_SHUTOFF_VALVE	
D9 Green	DC-powered O ₃ Pump status	O3_PUMP_ON	Pump should start /stop. If not: <ul style="list-style-type: none"> Failed pump Failed Drive IC on Relay PCA Failed Relay PCA Faulty +12 VDC Supply (PS2) Faulty Connectors/Wiring
D10 Green	T703U Divert Valve status	O3_DIVERT_VALVE	Valve should audibly change states. If not: <ul style="list-style-type: none"> Failed Valve Failed Relay Drive IC on Relay PCA Failed Relay PCA Faulty +12 VDC Supply (PS2) Faulty Connectors/Wiring
D11 Green	T703U O ₃ Generator Valve status	O3_GEN_VALVE	
D15 Green	Photometer Heater status	PHOTO_LAMP_HEATER	Voltage displayed should change. If not: <ul style="list-style-type: none"> Failed Heater

D16 Green	Status of O ₃ Generator Heater status	O3_GEN_HEATER	<ul style="list-style-type: none"> • Faulty Temperature Sensor • Failed AC Relay • Faulty Connectors/Wiring
--------------	--	----------------------	--

8.4. SUBSYSTEM CHECKOUT

The preceding sections of this manual discussed a variety of methods for identifying possible sources of failures or performance problems within the T703 calibrator. In most cases, this includes a list of possible components or subsystems that might be the source of the problem. This section describes how to check individual components or subsystems to determine if which is actually the cause of the problem being investigated.

8.4.1. VERIFY SUBSYSTEM CALIBRATION

A good first step when troubleshooting the operation of the T703 calibrator is to verify that its major subsystems are properly calibrated. These are:

- Test Channel D > A conversion (see Section 4.9.2).
- Gas pressure calibration (see Section 6.3).
- Photometer calibration (see Section 6.1).
- O₃ generator calibration (see Section 6.2).

8.4.2. AC MAIN POWER

The T703 calibrator's electronic systems will operate with any of the specified power regimes. As long as system is connected to 100-120 VAC or 220-240 VAC at either 50 or 60 Hz it will turn on and after about 30 seconds show a front panel display.

- Internally, the status LEDs located on the Relay PCA, motherboard and CPU should turn on as soon as the power is supplied.
- If they do not, check the circuit breaker built into the ON/OFF switch on the instruments front panel



CAUTION

SHOULD THE AC POWER CIRCUIT BREAKER TRIP, INVESTIGATE AND CORRECT THE CONDITION CAUSING THIS SITUATION BEFORE TURNING THE CALIBRATOR BACK ON.

8.4.3. DC POWER SUPPLY

If you have determined that the calibrator's AC mains power is working, but the unit is still not operating properly, there may be a problem with one of the instrument's switching power supplies. The supplies can have two faults, namely no DC output, and noisy output.

To assist tracing DC Power Supply problems, the wiring used to connect the various printed circuit assemblies and DC Powered components and the

associated test points on the relay PCA follow a standard color-coding scheme as defined in the following table.

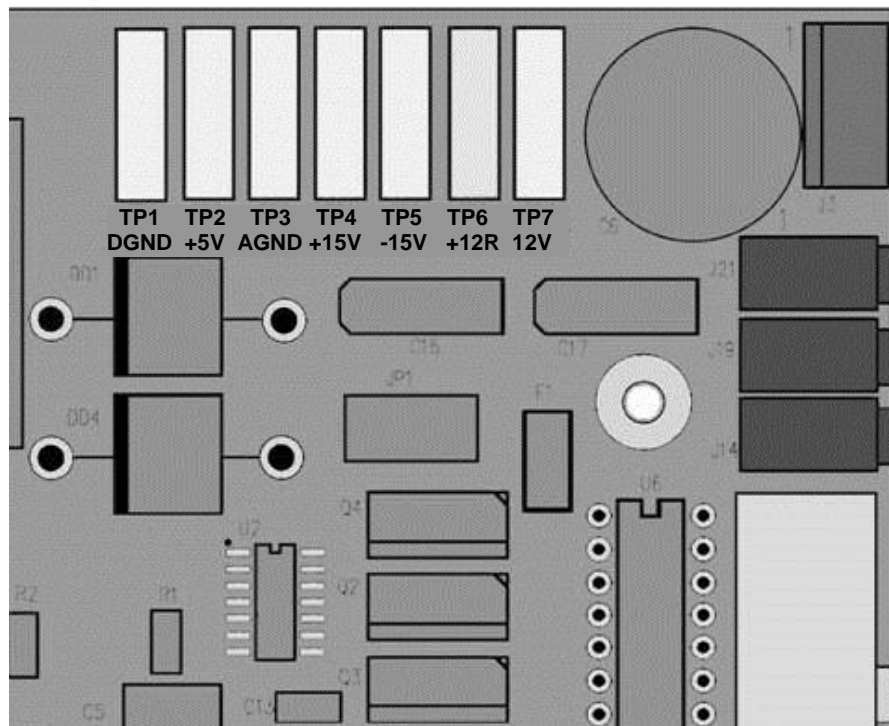

Figure 8-4: Location of DC Power Test Points on Relay PCA

Table 8-6: DC Power Test Point and Wiring Color Codes

NAME	TEST POINT#	TP AND WIRE COLOR
Dgnd	1	Black
+5V	2	Red
Agnd	3	Green
+15V	4	Blue
-15V	5	Yellow
+12R	6	Purple
+12V	7	Orange

A voltmeter should be used to verify that the DC voltages are correct per the values in the table below, and an oscilloscope, in AC mode, with band limiting turned on, can be used to evaluate if the supplies are producing excessive noise (> 100 mV p-p).

Table 8-7: DC Power Supply Acceptable Levels

POWER SUPPLY	VOLTAGE	CHECK RELAY PCA TEST POINTS		MIN V	MAX V
		FROM TEST POINT	TO TEST POINT		

ASSY		NAME	#	NAME	#		
PS1	+5	Dgnd	1	+5	2	4.8	5.25
PS1	+15	Agnd	3	+15	4	13.5	16V
PS1	-15	Agnd	3	-15V	5	-14V	-16V
PS1	Agnd	Agnd	3	Dgnd	1	-0.05	0.05
PS1	Chassis	Dgnd	1	Chassis	N/A	-0.05	0.05
PS2	+12	+12V Ret	6	+12V	7	11.75	12.5
PS2	+12 V ret	+12V Ret	6	Dgnd	1	-0.05	0.05

8.4.4. I²C BUS

Operation of the I²C bus can be verified by observing the behavior of D1 on the relay PCA & D2 on the Valve Driver PCA. Assuming that the DC power supplies are operating properly, the I²C bus is operating properly if D1 on the relay PCA and D2 of the Valve Driver PCA are flashing

There is a problem with the I²C bus if both D1 on the relay PCA and D2 of the Valve Driver PCA are ON/OFF constantly.

8.4.5. TOUCHSCREEN INTERFACE

Verify the functioning of the touch screen by observing the display when pressing a touch-screen control button. Assuming that there are no wiring problems and that the DC power supplies are operating properly, but pressing a control button on the touch screen does not change the display, any of the following may be the problem:

- The touch-screen controller may be malfunctioning.
- The internal USB bus may be malfunctioning.

You can verify this failure by logging on to the instrument using APICOM or a terminal program. If the instrument responds to remote commands and the display changes accordingly, the touch-screen interface may be faulty.

8.4.6. LCD DISPLAY MODULE

Verify the functioning of the front panel display by observing it when power is applied to the instrument. Assuming that there are no wiring problems and that the DC power supplies are operating properly, the display screen should light and show the splash screen and other indications of its state as the CPU goes through its initialization process.

8.4.7. RELAY PCA

The Relay PCA can be most easily checked by observing the condition of the status LEDs located along its upper edge (see Section 8.3.2 and Figure 8-3:

Relay PCA Status LEDs Used for Troubleshooting), and using the **SIGNAL I/O** submenu under the **DIAG** menu (see Section 8.1.3) to toggle each LED **ON** or **OFF**.

If D1 on the Relay PCA is flashing and the status indicator for the output in question (Pump power, Heater power, Valve Drive, etc.) toggles properly using the Signal I/O function, then the associated control device on the Relay PCA is bad. Several of the control devices are in sockets and can be easily replaced. The table below lists the control device associated with a particular function.

Table 8-8: Relay PCA Control Devices

FUNCTION	CONTROL DEVICE	IN SOCKET
UV Lamp Heater	Q2	No
O ₃ Gen Heater	Q3	No
All Valves	U5	Yes
AC Dry air Pump	K1	No
DC Photometer Pump	U1	No

8.4.8. PHOTOMETER O₃ GENERATOR PRESSURE /FLOW SENSOR ASSEMBLY

This assembly is only present in calibrators with O₃ generator and/or photometer installed. The pressure/flow sensor PCA, located at the rear of the instrument between the O₃ generator and the photometer pump (see Figure 3-5 for T703; see Figure 3-7 for T703U) can be checked with a Voltmeter. The following procedure assumes that the wiring is intact and that the motherboard as well as the power supplies are operating properly:

BASIC PCA OPERATION:

- Measure the voltage across C1; it should be 10 VDC \pm 0.25 VDC. If not then the board is bad.
- Measure the voltage between TP2 and TP1 C1; it should be 10 VDC \pm 0.25 VDC. If not then the board is bad.
- Measure the voltage across C2; it should be 5 VDC \pm 0.25 VDC. If not then the board is bad.

PHOTOMETER PRESSURE SENSOR (ABSOLUTE PRESSURE):

1. Measure the pressure on the inlet side of S1 with an external pressure meter.
2. Measure the voltage across TP4 and TP1.
 - The expected value for this signal should be:

$$\text{Expected mVDC} = \left(\frac{\text{Pressure}}{30.0_{\text{Hg-in-A}}} \times 4660_{\text{mVDC}} \right) + 250_{\text{mVDC}} \quad \pm 10\%_{\text{rdg}}$$

EXAMPLE: If the measured pressure is 20 Hg-in-A, the expected voltage level between TP4 and TP1 would be between 2870 mVDC and 3510 mVDC.

EXAMPLE: If the measured pressure is 25 Hg-in-A, the expected voltage level between TP4 and TP1 would be between 3533 mVDC and 4318 mVDC.

- If this voltage is out of range, then either pressure transducer S1 is bad, the board is bad or there is a pneumatic failure preventing the pressure transducer from sensing the absorption cell pressure properly.

O₃ GENERATOR PRESSURE SENSOR (GAUGE PRESSURE):

1. Measure the pressure on the inlet side of S2 with an external pressure meter.
2. Measure the voltage across TP5 and TP1.
 - The expected value for this signal should be:

$$\text{Expected mVDC} = \left(\frac{\text{Pressure}}{100_{\text{psig}}} \times 4250_{\text{mVDC}} \right) + 250_{\text{mVDC}} \quad \pm 10\%_{\text{rdg}}$$

EXAMPLE: If the measured pressure is 25 psig, the expected voltage level between TP4 and TP1 would be between 1182 mVDC and 1444 mVDC.

EXAMPLE: If the measured pressure is 30 psig, the expected voltage level between TP4 and TP1 would be between 1373 mVDC and 1677 mVDC.

- If this voltage is out of range, then either pressure transducer S1 is bad, the board is bad or there is a pneumatic failure preventing the pressure transducer from sensing the absorption cell pressure properly.

PHOTOMETER FLOW SENSOR:

- Measure the voltage across TP3 and TP1.
 - With proper flow (800 cc³/min through the photometer), this should be approximately 4.5V (this voltage will vary with altitude).
 - With flow stopped (photometer inlet disconnected or pump turned OFF) the voltage should be approximately 1V.
 - If the voltage is incorrect, the flow sensor S3 is bad, the board is bad or there is a leak upstream of the sensor.

8.4.9. MOTHERBOARD

8.4.9.1. A/D Functions

The simplest method to check the operation of the A-to-D converter on the motherboard is to use the Signal I/O function under the DIAG menu to check the two A/D reference voltages and input signals that can be easily measured with a voltmeter.

1. Use the Signal I/O function (See Section 8.1.3 and Appendix A) to view the value of **REF_4096_MV** and **REF_GND**. If both are within 3 mV of nominal (4096 and 0), and are stable, ± 0.5 mV then the basic A/D is functioning properly. If not then the motherboard is bad.
2. Choose a parameter in the Signal I/O function such as **PHOTO_LAMP_DRIVE**, **O3_GEN_TEMP** or **PHOTO_FLOW**.
 - Compare these voltages at their origin (see the interconnect drawing and interconnect list in Appendix D) with the voltage displayed through the signal I/O function.
 - If the wiring is intact but there is a large difference between the measured and displayed voltage (± 10 mV) then the motherboard is bad.

8.4.9.2. Test Channel / Analog Outputs Voltage

To verify that the analog output is working properly, connect a voltmeter to the output in question and perform an analog output step test as follows:

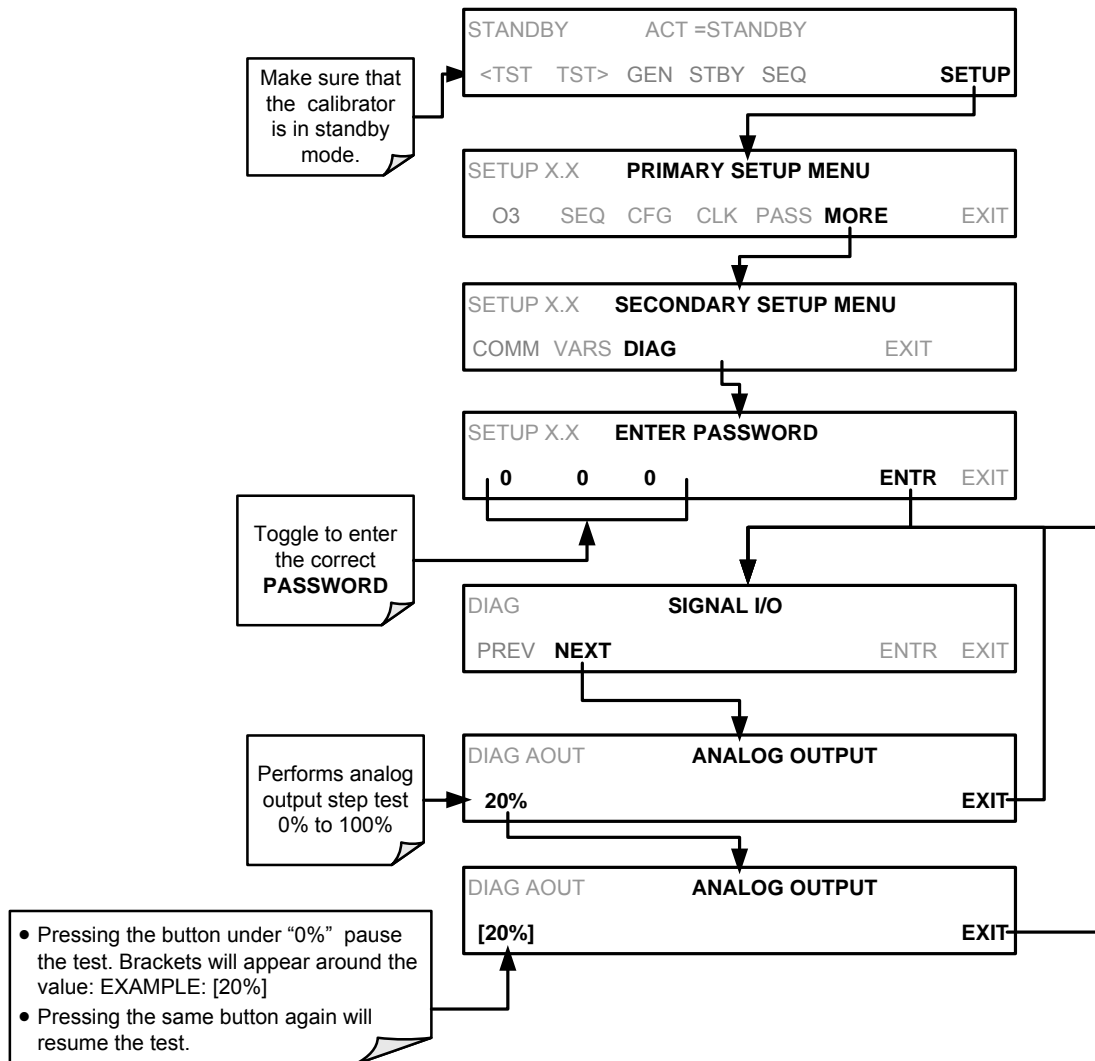

For each of the steps the output should be within 1% of the nominal value listed in the table below except for the 0% step, which should be within 0mV ±2 to 3 mV. Make sure you take into account any offset that may have been programmed into channel (See Section 4.9.1.5).

Table 8-9: Analog Output Test Function - Nominal Values Voltage Outputs

		FULL SCALE OUTPUT OF VOLTAGE RANGE (see Section 4.9.1.3)			
		100mV	1V	5V	10V
STEP	%	NOMINAL OUTPUT VOLTAGE			
1	0	0	0	0	0
2	20	20 mV	0.2	1	2
3	40	40 mV	0.4	2	4
4	60	60 mV	0.6	3	6
5	80	80 mV	0.8	4	8
6	100	100 mV	1.0	5	10

If one or more of the steps fails to be within these ranges, it is likely that there has been a failure of the either or both of the DACs and their associated circuitry on the motherboard.

8.4.9.3. Status Outputs

To test the status output electronics:

1. Connect a jumper between the “D” pin and the “▽” pin on the status output connector.
2. Connect a 1000 ohm resistor between the “+” pin and the pin for the status output that is being tested.
3. Connect a voltmeter between the “▽” pin and the pin of the output being tested (see table below).
4. Under the **DIAG> SIGNAL I/O** menu (See Section 8.1.3), scroll through the inputs and outputs until you get to the output in question.
5. Alternately, turn on and off the output noting the voltage on the voltmeter.
 - It should vary between 0 volts for ON and 5 volts for OFF.

Table 8-10: Status Outputs Check

PIN (LEFT TO RIGHT)	STATUS
1	ST_SYSTEM_OK
2	SPARE
3	ST_CAL_ACTIVE
4	ST_DIAG_MODE
5	ST_TEMP_ALARM
6	ST_PRESS_ALARM
7 and 8	SPARE

8.4.9.4. Control Inputs

Table 8-11: T703 Control Input Pin Assignments and Corresponding Signal I/O Functions

CONNECTOR	INPUT	CORRESPONDING I/O SIGNAL
Top	A	CONTROL_IN_1
Top	B	CONTROL_IN_2
Top	C	CONTROL_IN_3
Top	D	CONTROL_IN_4
Top	E	CONTROL_IN_5
Top	F	CONTROL_IN_6
Bottom	G	CONTROL_IN_7
Bottom	H	CONTROL_IN_8
Bottom	I	CONTROL_IN_9
Bottom	J	CONTROL_IN_10
Bottom	K	CONTROL_IN_11
Bottom	L	CONTROL_IN_12

The control input bits can be tested by applying a trigger voltage to an input and watching changes in the status of the associated function under the SIGNAL I/O submenu:

EXAMPLE: to test the “A” control input:

1. Under the **DIAG> SIGNAL I/O** menu (See Section 8.1.3), scroll through the inputs and outputs until you get to the output named **0) CONTROL_IN_1**.
2. Connect a jumper from the “+” pin on the appropriate connector to the “U” on the same connector.
3. Connect a second jumper from the “∇” pin on the connector to the “A” pin.
4. The status of **0) CONTROL_IN_1** should change to read “ON”.

8.4.9.5. Control Outputs

Table 8-12: Control Outputs Pin Assignments and Corresponding Signal I/O Functions Check

PIN (LEFT TO RIGHT)	STATUS
1	CONTROL_OUT_1
2	CONTROL_OUT_2
3	CONTROL_OUT_3
4	CONTROL_OUT_4
5	CONTROL_OUT_5
6	CONTROL_OUT_6
7	CONTROL_OUT_7
8	CONTROL_OUT_8
9	CONTROL_OUT_9
10	CONTROL_OUT_10
11	CONTROL_OUT_11
12	CONTROL_OUT_12

To test the Control Output electronics:

1. Connect a jumper between the “E” pin and the “▽” pin on the status output connector.
2. Connect a 1000 ohm resistor between the “+” pin and the pin for the status output that is being tested.
3. Connect a voltmeter between the “▽” pin and the pin of the output being tested (see Table 8-12).
4. Under the **DIAG> SIGNAL I/O** menu (See Section 8.1.3), scroll through the inputs and outputs until you get to the output in question.
5. Alternately, turn on and off the output noting the voltage on the voltmeter.
 - It should vary between 0 volts for ON and 5 volts for OFF.

8.4.10. CPU

There are two major types of CPU board failures, a complete failure and a failure associated with the Disk On Module (DOM). If either of these failures occurs, contact the factory.

For complete failures, assuming that the power supplies are operating properly and the wiring is intact, the CPU is faulty if on power-on, the watchdog LED on the motherboard is not flashing.

In some rare circumstances, this failure may be caused by a bad IC on the motherboard, specifically U57, the large, 44 pin device on the lower right hand side of the board. If this is true, removing U57 from its socket will allow the instrument to start up but the measurements will be invalid.

If the instrument stops during initialization (the front panel display shows a fault or warning message), it is likely that the DOM, the firmware or the configuration and data files have been corrupted.

8.4.11. RS-232 COMMUNICATIONS

8.4.11.1. General RS-232 Troubleshooting

Teledyne API calibrators use the RS-232 communications protocol to allow the instrument to be connected to a variety of computer-based equipment. RS-232 has been used for many years and as equipment has become more advanced, connections between various types of hardware have become increasingly difficult. Generally, every manufacturer observes the signal and timing requirements of the protocol very carefully.

Problems with RS-232 connections usually center around four general areas:

- Incorrect cabling and connectors. See Section 5.1.2 for connector and pin-out information.
- The BAUD rate and protocol are incorrectly configured. See Section 5.1.3.
- If a modem is being used, additional configuration and wiring rules must be observed. See Section 5.2
- Incorrect setting of the DTE – DCE Switch is set correctly. See Section 5.1.1.

- Verify that cable (03596) that connects the serial COM ports of the CPU to J12 of the motherboard is properly seated

8.4.11.2. Troubleshooting Calibrator/Modem or Terminal Operation

These are the general steps for troubleshooting problems with a modem connected to a Teledyne API calibrator.

- Check cables for proper connection to the modem, terminal or computer.
- Check to make sure the DTE-DCE is in the correct position as described in Section 5.1.1.
- Check to make sure the set up command is correct (See Section 5.2)
- Verify that the Ready to Send (RTS) signal is at logic high. The T703 sets pin 7 (RTS) to greater than 3 volts to enable modem transmission.
- Make sure the BAUD rate, word length, and stop bit settings between modem and calibrator match, See Section 5.1.3.
- Use the RS-232 test function to send “w” characters to the modem, terminal or computer; See Section 5.1.5
- Get your terminal, modem or computer to transmit data to the calibrator (holding down the space bar is one way); the green LED should flicker as the instrument is receiving data.
- Make sure that the communications software or terminal emulation software is functioning properly.

NOTE

Further help with serial communications is available in a separate manual “RS-232 Programming Notes” Teledyne API part number 013500000.

8.4.12. TEMPERATURE PROBLEMS

Individual control loops are used to maintain the set point of the UV lamp and ozone generator. If any of these temperatures are out of range or are poorly controlled, the T703 will perform poorly.

8.4.12.1. Box / Chassis Temperature

The box temperature sensor is mounted to the motherboard and cannot be disconnected to check its resistance. Rather check the **BOX TEMP** signal using the **SIGNAL I/O** function under the **DIAG** Menu (see Section 8.1.3). This parameter will vary with ambient temperature, but at ~30°C (6-7° above room temperature) the signal should be ~1450 mV.

8.4.12.2. Photometer Sample Chamber Temperature

The temperature of the gas in the photometer sample chamber should read approximately 5.0°C higher than the box temperature.

8.4.12.3. UV Lamp Temperature

There are three possible causes for the UV Lamp temperature to have failed.

- The UV Lamp heater has failed. Check the resistance between pins 5 and 6 on the six-pin connector adjacent to the UV Lamp on the Optical Bench.
 - It should be approximately 30 Ohms.
- Assuming that the I²C bus is working and that there is no other failure with the Relay board, the FET Driver on the Relay Board may have failed.
 - Using the **PHOTO_LAMP HEATER** parameter under the **SIGNAL I/O** function of the **DIAG** menu, as described above, turn on and off the UV Lamp Heater (D15 on the relay board should illuminate as the heater is turned on).
 - Check the DC voltage present between pin 1 and 2 on J13 of the Relay Board.
 - If the FET Driver has failed, there will be no change in the voltage across pins 1 and 2.
- If the FET Driver Q2 checks out OK, the thermistor temperature sensor in the lamp assembly may have failed.
 - Unplug the connector to the UV Lamp Heater/Thermistor PCB, and measure the resistance of the thermistor between pins 5 and 6 of the 6-pin connector.
 - The resistance near the 58°C set point is ~8.1k ohms.

8.4.12.4. Ozone Generator Temperature

There are three possible causes for the Ozone Generator temperature to have failed.

- The O₃ generator heater has failed. Check the resistance between pins 5 and 6 on the 6-pin connector adjacent to the UV Lamp on the O₃ Generator. It should be approximately 5 Ohms.
- Assuming that the I²C bus is working and that there is no other failure with the Relay board, the FET Driver on the Relay Board may have failed. Using the **O3_GEN_HEATER** parameter under the **SIGNAL I/O** function of the **DIAG** menu, as described above, turn on and off the UV Lamp Heater. Check the DC voltage present between pin 1 and 2 on J14 of the Relay Board.

If the FET Driver has failed, there should be no change in the voltage across pins 1 and 2.

- If the FET Driver checks out OK, the thermistor temperature sensor in the lamp assembly may have failed. Unplug the connector to the Ozone Generator Heater/Thermistor PCB, and measure the resistance of the thermistor between pins 5 and 6 of the 6-pin connector.

8.5. TROUBLESHOOTING THE O₃ PHOTOMETER

8.5.1. DYNAMIC PROBLEMS WITH THE O₃ PHOTOMETER

Dynamic problems are problems, which only manifest themselves when the photometer is measuring O₃ concentration gas mixtures. These can be the most difficult and time consuming to isolate and resolve.

Since many photometer behaviors that appear to be a dynamic in nature are often a symptom of a seemingly unrelated static problems, it is recommended that dynamic problems not be addressed until all static problems, warning conditions and subsystems have been checked and any problems found are resolved.

Once this has been accomplished, the following most common dynamic problems should be checked.

8.5.1.1. Noisy or Unstable O₃ Readings at Zero

- Check for leaks in the pneumatic system as described in Section 7.2
- Confirm that the Zero gas is free of Ozone.
- Confirm that the Source Lamp is fully inserted and that the lamp hold-down thumb- screw is tight.
- Check for a dirty Absorption Cell and/or pneumatic lines. Clean as necessary as described in Section 7.2
- Disconnect the exhaust line from the optical bench (the pneumatic line at the lamp end of the bench) and plug the port in the bench. If readings remain noisy, the problem is in one of the electronic sections of the instrument. If readings become quiet, the problem is in the instrument's pneumatics.

8.5.1.2. Noisy, Unstable, or Non-Linear Span O₃ Readings

- Check for leaks in the pneumatic systems as described in Section 7.2.
- Check for proper operation of the meas/ref switching valve as described in Section 8.5.2.
- Check for dirty absorption cell and clean or replace as necessary as described in Section 7.2
- Check for operation of the A/D circuitry on the motherboard. See Section 8.4.9.1.
- Confirm the Sample Temperature, Sample Pressure and Sample Flow readings are correct. Check and adjust as required.

8.5.1.3. Slow Response to Changes in Concentration

- Check for dirty absorption cell and clean or replace as necessary as described in Section 7.2
- Check for pneumatic leaks as described in Section 7.2
- Check for improper materials in the inlet manifold.
- The photometer needs 800 cc³/min of gas flow. Make sure that this is accounted for when calculating total required output flow for the calibrator (see Section 3.4.7).

8.5.1.4. The Analog Output Signal Level Does Not Agree With Front Panel Readings

- Confirm that the recorder offset (see Section 4.9.1.5) is set to zero.
- Perform an AOUTS calibration (see Section 4.9.2) and photometer dark calibration (see Section 6.1.4).

8.5.1.5. Cannot Zero

- Check for leaks in the pneumatic system as described in Section 7.2.
- Confirm that the Zero gas is free of Ozone.
- The photometer needs 800 cc³/min of gas flow. Make sure that this is accounted for when calculating total required output flow for the calibrator (see Section 3.4.7).

8.5.1.6. Cannot Span

- Check for leaks in the pneumatic systems as described in Section 7.2.
- Check for proper operation of the meas/ref switching valve as described in Section 8.5.2.
- Check for dirty absorption cell and clean or replace as necessary as described in Section 7.2
- Check for operation of the A/D circuitry on the motherboard. See Section 8.4.9.1.
- Confirm the Sample Temperature, Sample Pressure and Sample Flow readings are correct. Check and adjust as required.
- The photometer needs 800 cc³/min of gas flow. Make sure that this is accounted for when calculating total required output flow for the calibrator (see Section 3.4.7).

8.5.2. CHECKING MEASURE / REFERENCE VALVE

To check the function of the photometer's measure / reference valve:

1. Set the calibrator's front panel display to show the **PHOTO REFERENCE** test function (see Section 4.1).
2. Follow the instructions in Sections 6.1.1 and 6.1.3.1 for performing a zero point calibration of the photometer.
 - Press **XZRO** and allow the calibrator to stabilize.
3. Before completing the calibration by pressing the **ZERO** button, note of the displayed value.
4. Press the final Zero button, then press "**NO**" when asked, "**ARE YOU SURE**".
5. Follow the instructions in Section 6.1.3.2 for performing a span point calibration of the photometer.
 - Press **XSPN** and allow the calibrator to stabilize.
6. Before completing the calibration by pressing the SPAN button, note of the displayed value of PHOTO REF.
 - If the O₃ REF value has decreased by more than 2 mV from its value with Zero-gas, then there is a "cross-port" leak in the m/r valve.
7. Press the final Zero button then press "**NO**" when asked, "**ARE YOU SURE**".

8.6. TROUBLE SHOOTING THE O₃ GENERATOR

Troubleshooting the O₃ generator differs between the T703 (Section 8.6.1) and the T703U (Section 8.6.2).

**WARNING****Hazardous voltage present - use caution.****8.6.1. TROUBLESHOOTING THE O₃ GENERATOR IN THE T703**

(See Section 8.6.1 for troubleshooting the T703U O₃ generator).

1. Unplug the cable connector at P1 on the Lamp Power Supply and confirm that +15VDC is present between Pins 1 and 2 on the cable connector.
2. If this voltage is incorrect, check the DC test points on the relay PCA as described in Section 8.4.3.
3. Begin generating O₃.
4. Scroll to the Test Function **O3GENDRV** and note the reading in mVDC [XXXX.X].
5. Remove the cover of the O₃ generator and check for the presence of the following voltages on the UV lamp power supply PCA:
 - Reading between TP1 and TP4 (grnd) should match the **O3GENDRV** test function reading [XXXX.X] mVDC \pm 10 mVDC
If this voltage is incorrect, either the UV lamp power supply PCA is faulty or the I²C bus is not communicating with the UV lamp power supply PCA.
 - Reading of +5VDC should be seen between TP3 and TP4 (grnd).
If this voltages is less than 4.8 or greater than 5.25, either the 5 VDC power supply or the UV lamp power supply PCA are faulty.

If the above voltages check out, it is more likely that a problem is due to the UV Lamp than due to the Lamp Power Supply. Replace the UV Lamp and if the problem persists, replace the Lamp Power Supply.

8.6.2. TROUBLESHOOTING THE O₃ GENERATOR IN THE T703U

(See Section 8.6.1 for troubleshooting the T703 O₃ generator).

1. Make sure the calibrator is idling in **STANDBY** mode.
2. Unplug the cable connector at P1 on the Lamp Power Supply and confirm that +15VDC is present between Pins 1 and 2 on the cable connector.
3. If this voltage is incorrect, check the DC test points on the relay PCA as described in Section 8.4.3.
4. Remove the cover of the photometer (see Figure 9-23) and check for the presence of the following voltages on the UV lamp power supply PCA:
 - +800 mVDC \pm 10 mVDC between TP1 and TP4 (grnd)
If this voltage is incorrect, either the UV lamp power supply PCA is faulty or the I²C bus is not communicating with the UV lamp power supply PCA.
 - +5VDC between TP3 and TP4 (grnd)
If this voltages is less than 4.8 or greater than 5.25, either the 5 VDC power supply or the UV lamp power supply PCA are faulty.

If the above voltages check out, it is more likely that a problem is due to the UV Lamp than due to the Lamp Power Supply. Replace the UV Lamp and if the problem persists, replace the Lamp Power Supply.

8.7. REPAIR PROCEDURES

8.7.1. REPAIRING SAMPLE FLOW CONTROL ASSEMBLY

The critical flow orifice is housed in the flow control assembly (Teledyne API part number: 001760400) located on the top of the optical bench. A sintered filter protects the jewel orifice so it is unusual for the orifice to need replacing, but if it does, or the filter needs replacement please use the following procedure (see the Spare Parts list in Appendix B for part numbers and kits):

1. Turn off power to the calibrator.
2. Locate the assembly to be repaired, see Figure 9-1 (T703) or Figure 9-2 (T703U).
3. Disconnect the pneumatic connection from the flow assembly.
4. Remove the fitting and the components as shown in the exploded view in Figure 8-5.
5. Replace the o-rings (p/n OR000001) and the sintered filter (p/n FL000001).
6. If replacing the critical flow orifice itself (P/N 000941000), make sure that the side with the colored window (usually red) is facing downstream to the gas flow.
7. Apply new Teflon[®] tape to the male connector threads.
8. Reassemble in reverse order.

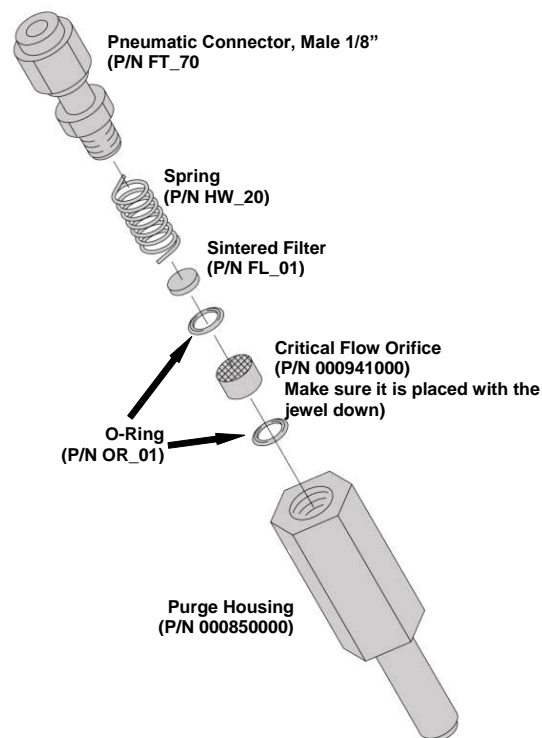

Figure 8-5: Critical Flow Restrictor Assembly Disassembly

8.7.2. DISK-ON-MODULE REPLACEMENT PROCEDURE

NOTE

Printed circuit assemblies (PCAs) are sensitive to electro-static discharges too small to be felt by the human nervous system. Failure to use ESD protection when working with electronic assemblies will void the instrument warranty.

For more information on preventing ESD damage see *A Primer on Electro-Static Discharge*; the manual can be downloaded from our website at <http://www.teledyne-api.com> under Help Center > Product Manuals in the Special Manuals section.

Replacing the Disk-on-Module (DOM) will cause loss of all DAS data; it also may cause loss of some instrument configuration parameters unless the replacement DOM carries the exact same firmware version. Whenever changing the version of installed software, the memory must be reset. Failure to ensure that memory is reset can cause the instrument to malfunction, and invalidate measurements.

After the memory is reset, the A/D converter must be re-calibrated, and all information collected in Step 1 below must be re-entered before the instrument will function correctly. Also, zero and span calibration should be performed.

1. Document all instrument parameters that may have been changed, such as range, auto-cal, analog output, serial port and other settings before replacing the DOM. (You will need this information to re-enter at the end of this procedure).
2. Turn off power to the instrument, fold down the rear panel by loosening the mounting screws.
3. When looking at the electronic circuits from the back of the instrument, locate the Disk-on-Module in the right most socket of the CPU board.
4. The DOM should carry a label with firmware revision, date and initials of the programmer.
5. Remove the nylon fastener that mounts the DOM over the CPU board, and lift the DOM off the CPU. Do not bend the connector pins.
6. Install the new Disk-on-Module, making sure the notch at the end of the chip matches the notch in the socket.
7. It may be necessary to straighten the pins somewhat to fit them into the socket. Press the DOM all the way in and reinsert the offset clip.
8. Close the rear panel and turn on power to the machine.
9. If the replacement DOM carries a firmware revision, re-enter all of the setup information.
10. Recalibrate A/D converter, and conduct a Zero and Span calibration as well.

8.8. FAQ'S

The following list is from the TAPI Technical Support Department of the 10 most commonly asked questions relating to the Model T703 Photometric Calibrator.

QUESTION	ANSWER
My ozone ACT =XXXX, why?	Look at the Photo Ref/Meas readings from the photometer UV lamp detector are most likely too low and need to be adjusted. See Section 7.5
When I generate ozone, it takes a long time to settle out or it fluctuates around the target concentration until finally stabilizing.	Perform an O ₃ Gen Calibration. See Section 6.2.
Why does the ENTR key sometimes disappear on the front panel display?	Sometimes the ENTR key will disappear if you select a setting that is invalid or out of the allowable range for that parameter, such as trying to set the 24-hour clock to 25:00:00. Once you adjust the setting to an allowable value, the ENTR button will re-appear.
How do I make the RS-232 Interface Work?	See Sections 3.2.6.3 and 5.1
When should I change the sintered filter(s) in the calibrators flow control(s) and how do I change them?	The sintered filters do not require regular replacement. Should one require replacement as part of a troubleshooting or repair exercise, see Section 8.7.1.
How often should I rebuild the photometer pump on my calibrator?	The photometer pump has been designed for longer service life than standard diaphragm pumps. When the pump wears out, the entire pump must be replaced.
How long do the UV lamps of the O ₃ generator and photometer last?	The typical lifetime is about 2-3 years.

8.9. TECHNICAL ASSISTANCE

If this manual and its trouble-shooting / service sections do not solve your problems, technical assistance may be obtained from

TELEDYNE-API, TECHNICAL SUPPORT
9480 CARROLL PARK DRIVE
SAN DIEGO, CALIFORNIA 92121-5201
USA

Toll-free Phone: 800-324-5190
Phone: 858-657-9800
Fax: 858-657-9816
Email: sda_techsupport@teledyne.com
Website: <http://www.teledyne-api.com/>

Before you contact Technical Support, fill out the problem report form in Appendix C, which is also available online for electronic submission at <http://www.teledyne-api.com/forms/>.

9. PRINCIPLES OF OPERATION

9.1. PNEUMATIC OPERATION

9.1.1. GAS FLOW CONTROL

Gas flow rates are set by various flow control assemblies in the gas stream(s), locations indicated in Figure 9-1Figure 9-2.

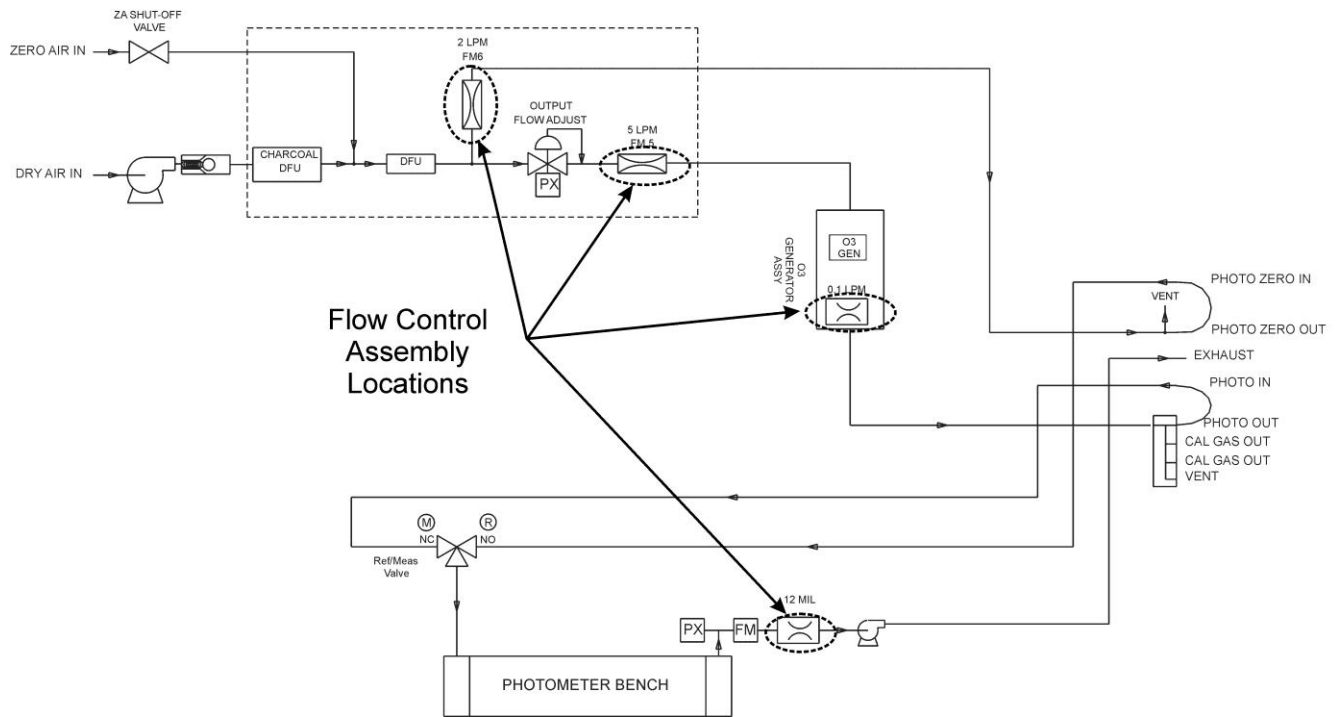

Figure 9-1. Location of Gas Flow Control Assemblies - T703

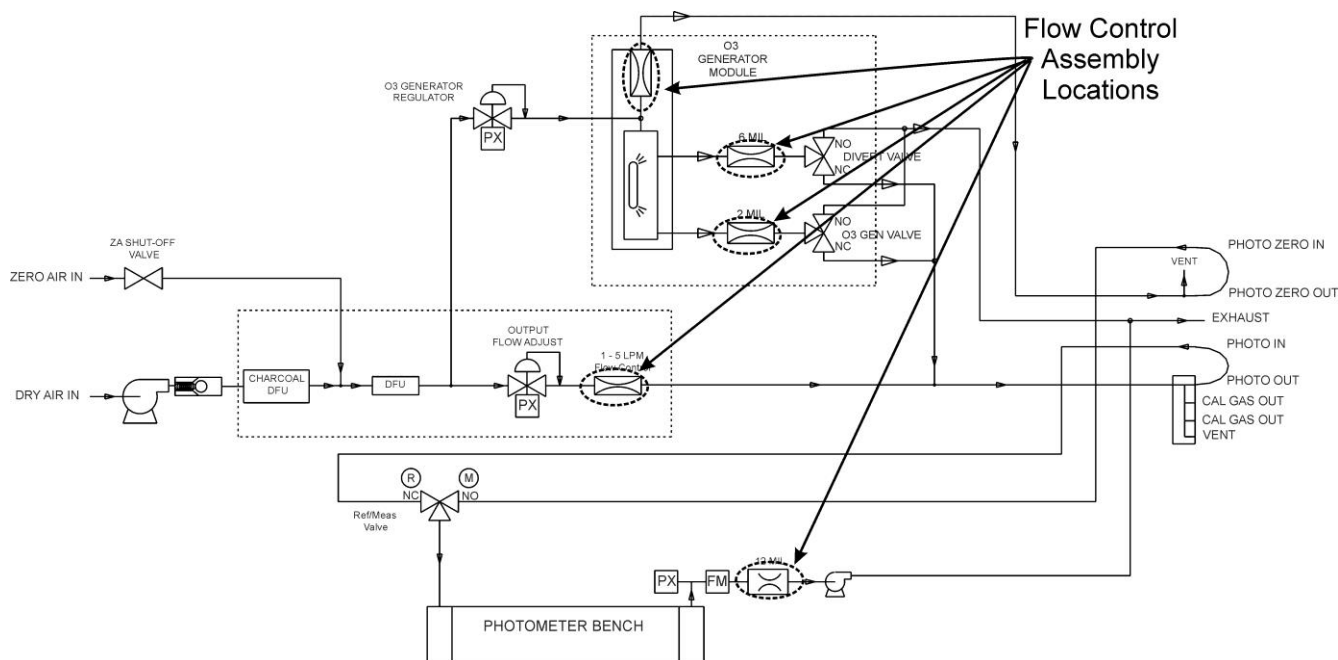

Figure 9-2: Location of Gas Flow Control Assemblies - T703U

9.1.1.1. Photometer Critical Flow Orifice

Critical flow orifices are a remarkably simple way to regulate stable gas flow rates. They operate without moving parts by taking advantage of the laws of fluid dynamics. By restricting the flow of gas through the orifice, a pressure differential is created. This pressure differential combined with the action of the calibrator's pump draws the gas through the orifice.

As the pressure on the downstream side of the orifice (the pump side) continues to drop, the speed that the gas flows through the orifice continues to rise. Once the ratio of upstream pressure to downstream pressure is greater than 2:1, the velocity of the gas through the orifice reaches the speed of sound. As long as that ratio stays at least 2:1 the gas flow rate is unaffected by any fluctuations, surges, or changes in downstream pressure because such variations only travel at the speed of sound themselves and are therefore cancelled out by the sonic shockwave at the downstream exit of the critical flow orifice.

The actual flow rate of gas through the orifice (volume of gas per unit of time), depends on the size and shape of the aperture in the orifice. The larger the hole, the more gas molecules, moving at the speed of sound, pass through the orifice.

9.1.2. INTERNAL GAS PRESSURE SENSORS

There are two pressure sensors in the T703/T703U: one for the regulator and one for the photometer. See Figure 3-5 (T703) or Figure 3-7 (T703U) for the location of the Pressure/Flow Sensor.

A 100 psig pressure sensor on this PCA is used to monitor the downstream regulator pressure. This value is displayed on the front panel as a test measurement called **REG PRESSURE**.

A second pressure located on the rear PCA measures the pressure of gas in the photometer's absorption tube. This sensor is a 0-15 psia (absolute pressure)

range sensor. This data is used by the CPU when calculating the O₃ concentration inside the absorption tube. This value is displayed on the front panel as a test measurement called **PHOTO SPRESS**. Note that this value is converted to units of Inches of Mercury (IN-HG-A) when displayed on the front panel.

9.2. ELECTRONIC OPERATION

9.2.1. OVERVIEW

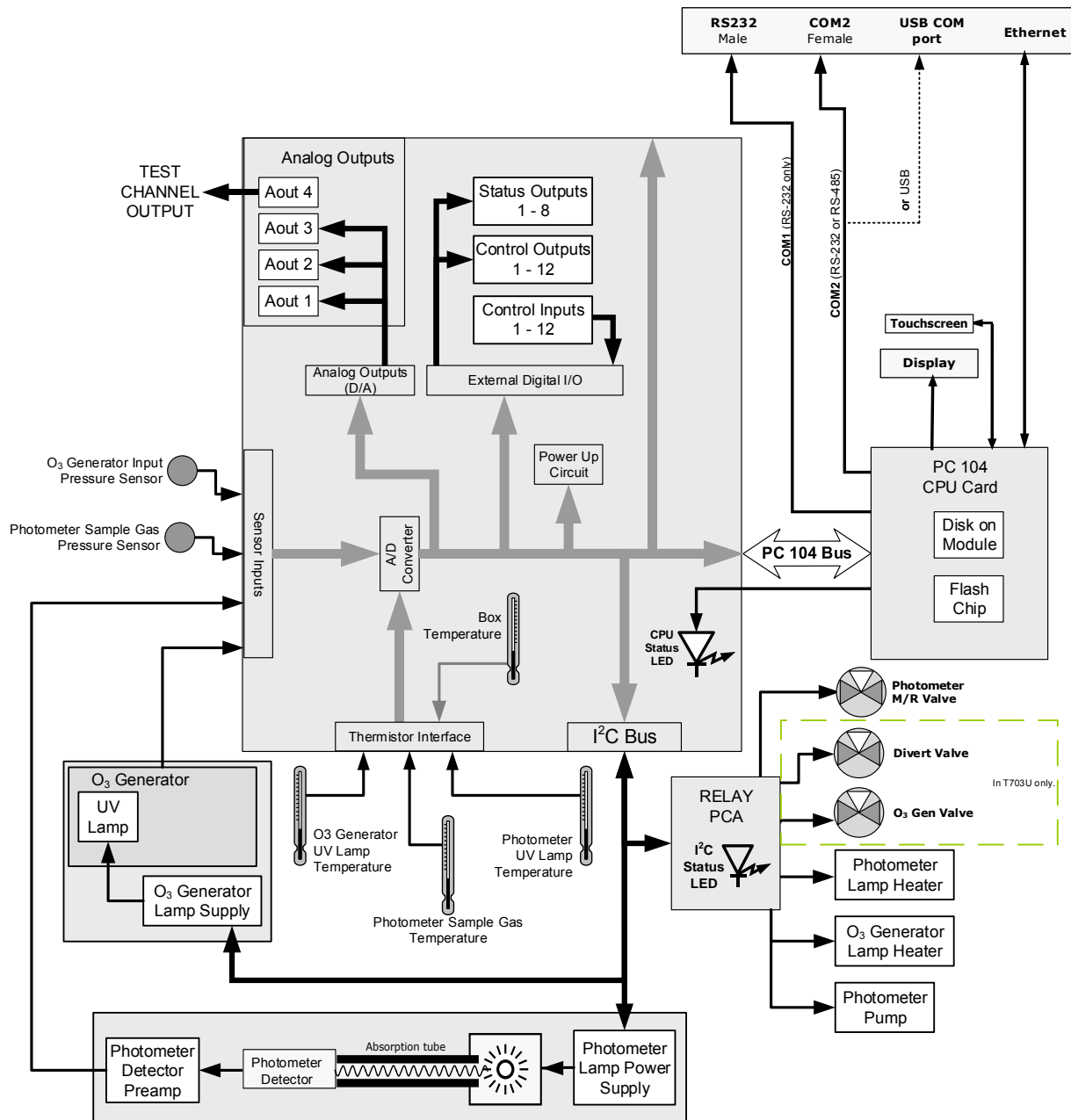

Figure 9-3: Electronic Block Diagram

The core of the calibrator is a microcomputer (referred to as the CPU) that controls various internal processes, interprets data, makes calculations, and

reports results using specialized firmware developed by Teledyne API. It communicates with the user as well as receives data from and issues commands to a variety of peripheral devices via a separate printed circuit assembly called the motherboard.

The motherboard is directly mounted to the inside rear panel and collects data, performs signal conditioning duties and routes incoming and outgoing signals between the CPU and the calibrator's other major components.

Data are generated by the various sub components of the T703 (e.g. flow data from the MFCs, O₃ concentration from the photometer). Analog signals are converted into digital data by a unipolar, analog-to-digital converter, located on the motherboard.

A variety of sensors report the physical and operational status of the calibrator's major components, again through the signal processing capabilities of the motherboard. These status reports are used as data for the concentration calculations and as trigger events for certain control commands issued by the CPU. They are stored in memory by the CPU and in most cases can be viewed but the user via the front panel display.

9.2.2. CENTRAL PROCESSING UNIT (CPU)

The unit's CPU card (Figure 9-4) is installed on the motherboard located inside the rear panel. It is a low power (5 VDC, 720mA max), high performance, Vortex 86SX-based microcomputer running Windows CE. Its operation and assembly conform to the PC-104 specification.

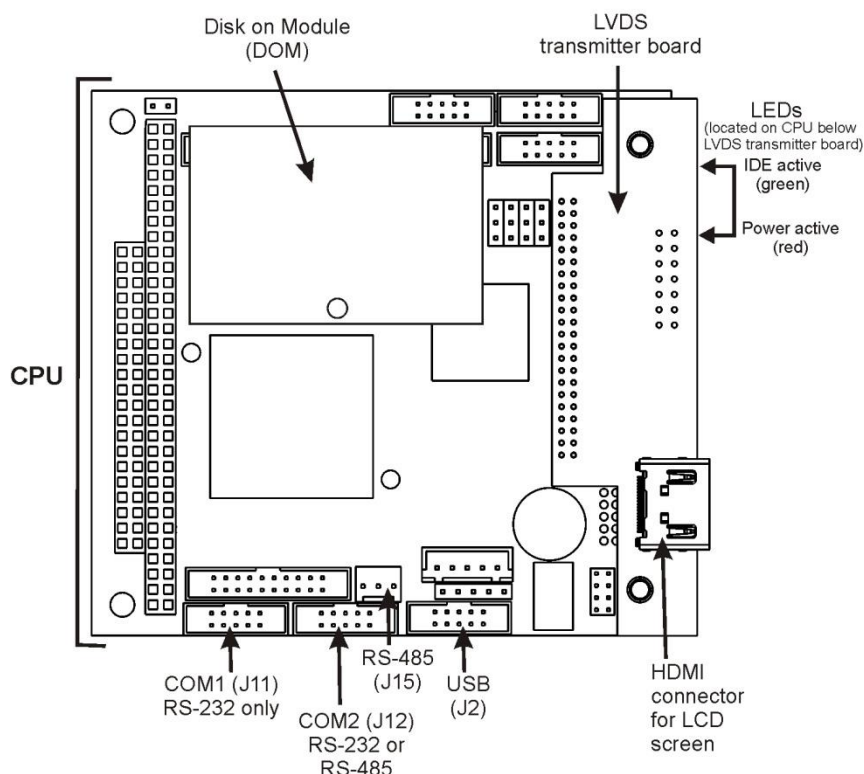

Figure 9-4: CPU Board Annotated

The CPU includes two types of non-volatile data storage: a Disk on Module (DOM) and an embedded flash chip.

9.2.2.1. Disk On Module (DOM)

The DOM is a 44-pin IDE flash chip with a storage capacity up to 256 MB. It is used to store the computer's operating system, the Teledyne API firmware, and most of the operational data.

9.2.2.2. Flash Chip

This non-volatile, embedded flash chip includes 2MB of storage for calibration data as well as a backup of the calibrator's configuration. Storing these key data onto a less frequently accessed chip significantly decreases the chance of data corruption.

In the unlikely event that the flash chip should fail, the calibrator will continue to operate with just the DOM. However, all configuration information will be lost, requiring the unit to be recalibrated.

9.2.3. RELAY PCA

The relay board is one of the central switching and power distribution units of the calibrator. It contains power relays, valve drivers and status LEDs for all heated zones and valves, as well as thermocouple amplifiers, power distribution connectors and the two switching power supplies of the calibrator. The relay board communicates with the motherboard over the I²C bus. Its status indicators and components can be used for troubleshooting power problems and valve or heater functionality.

Generally, the relay PCA is located in the right-rear quadrant of the calibrator and is mounted vertically on the backside of the same bracket as the instrument's DC power supplies, however the exact location of the relay PCA may differ from model to model.

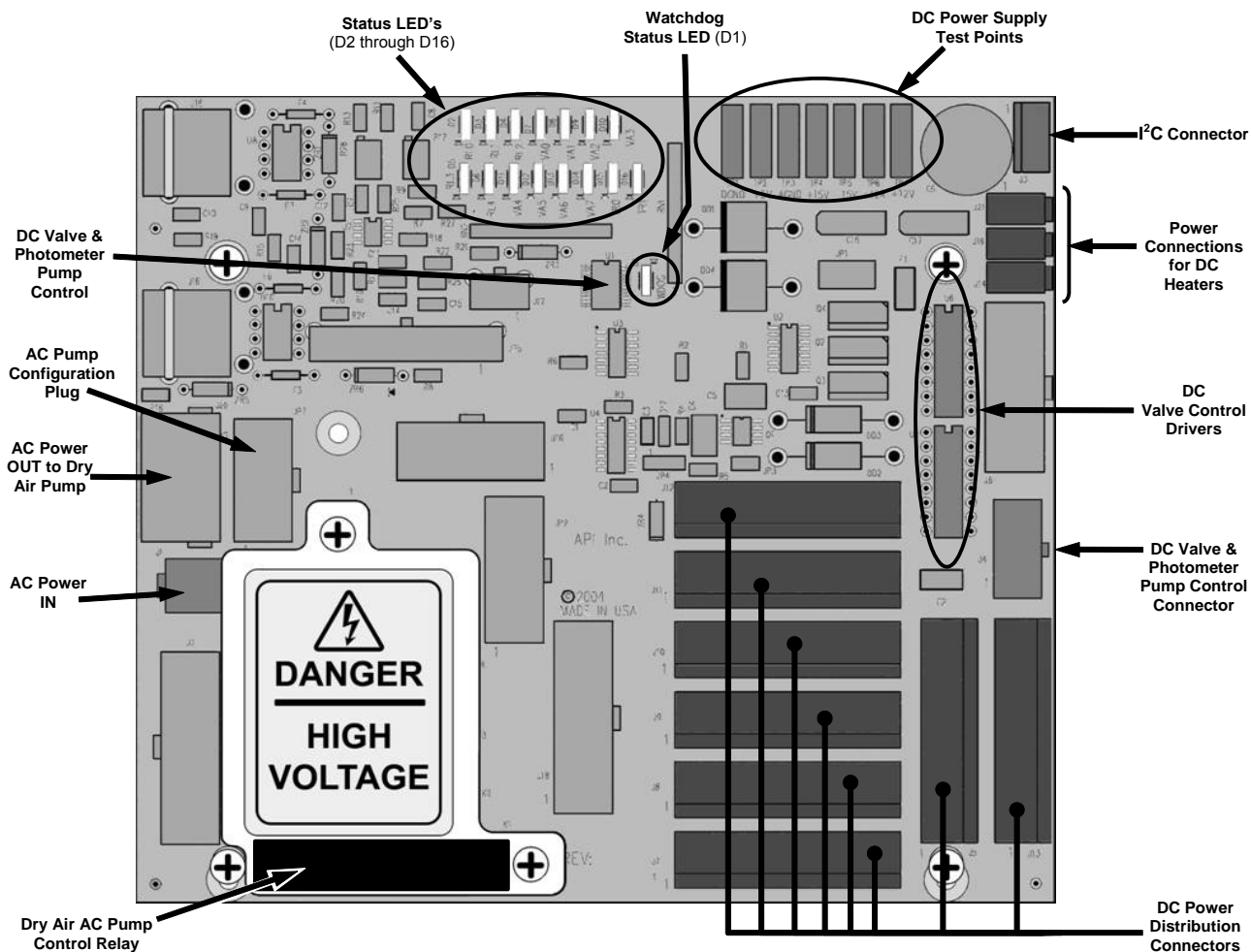

Figure 9-5: Relay Board PCA with AC Relay Retainer Removed

This version of the Relay PCA includes one AC relay that controls the AC-powered Dry Air (zero air) pump and A plastic insulating safety shield covers the remaining empty AC Relay sockets.



CAUTION

NEVER REMOVE THIS SAFETY SHIELD WHILE THE INSTRUMENT IS PLUGGED IN AND TURNED ON. THE CONTACTS OF THE AC RELAY SOCKETS BENEATH THE SHIELD CARRY HIGH AC VOLTAGES EVEN WHEN NO RELAYS ARE PRESENT

9.2.3.1. Valve Control

The relay board also hosts two valve driver IC's, each of which can drive up four valves. In the T703, the relay PCA controls only those valves associated with the O₃ generator and photometer.

In the T703U, the relay PCA controls two additional valves: the Divert valve and the O₃ Gen valve.

9.2.3.2. Heater Control

The relay PCA controls the DC heaters for the O₃ generator and photometer lamp housing.

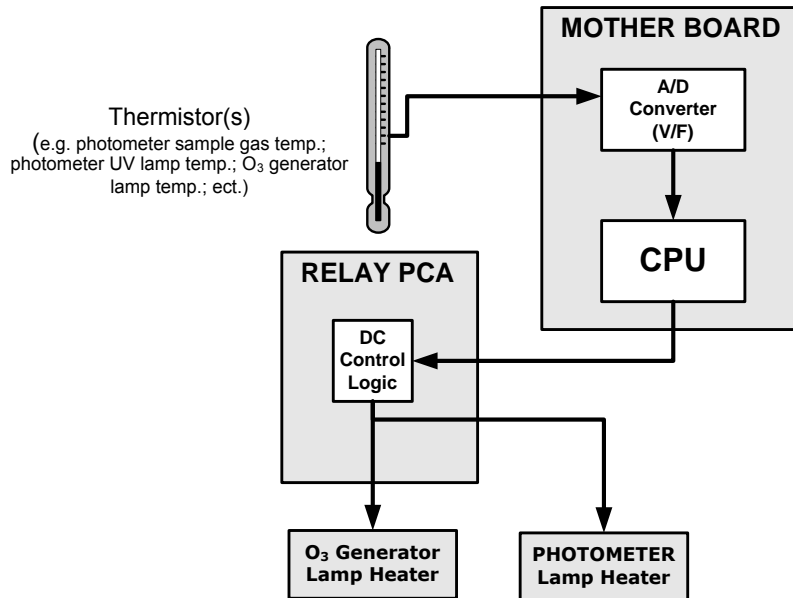

Figure 9-6: Heater Control Loop Block Diagram.

9.2.3.3. Relay PCA Status LEDs and Watch Dog Circuitry

Sixteen LEDs are located on the calibrator’s relay board (Figure 9-7) to indicate the status of the calibrator’s heating zones and some of its valves; included is a general operating watchdog indicator. Table 9-1 shows the states of these LEDs and their respective functionality. Not all LEDs are used.

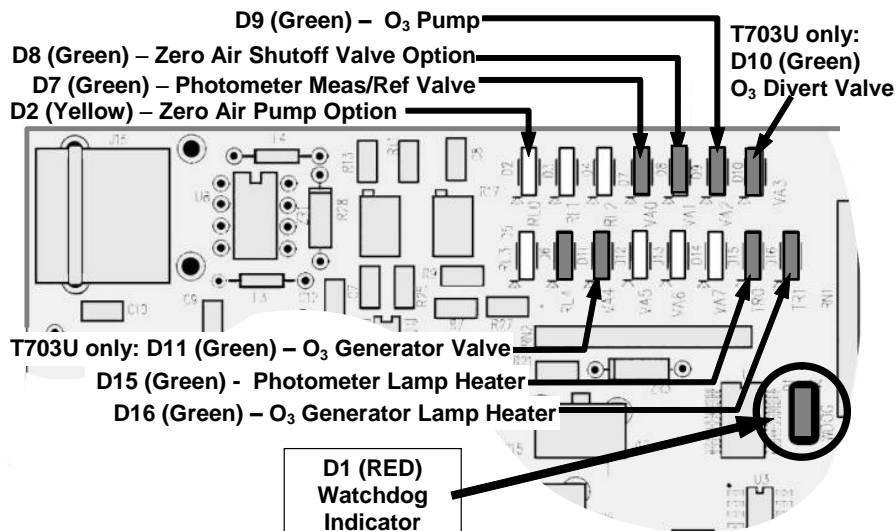

Figure 9-7: Status LED Locations – Relay PCA

Table 9-1: Relay Board Status LEDs

LED	COLOR	DESCRIPTION	FUNCTION/INDICATION
D1	Red	Watchdog Circuit; I ² C bus operation.	Blinks when I ² C bus is operating properly
D2	Yellow	Zero Air Pump (option) Status	When lit the zero air AC pump is running.
D3-6	SPARE		
D7	Green	Photometer Meas/Ref Valve Status	When lit the valve open to the Measure gas path; when not lit while instrument is running, the valve is open to the Reference gas path.
D8	Green	Zero Air Shutoff Valve (option) Status	When lit, ZA shutoff valve open.
D9	Green	O ₃ Pump Status	When lit, O ₃ pump running
D10	Green	T703U Divert Valve Status	when lit, divert valve open.
D11	Green	T703U O ₃ Generator Valve Status	When lit, O ₃ generator valve open.
D12 - 14	SPARE		
D15	Green	Photometer Lamp Heater Status	When lit the photometer UV lamp heater is on
D16	Green	O ₃ Generator Lamp Heater	When lit the O ₃ generator UV lamp heater is on

9.2.3.4. Relay PCA Watchdog Indicator (D1)

The most important of the status LEDs on the relay board is the red I²C Bus watchdog LED. It is controlled directly by the calibrator's CPU over the I²C bus. Special circuitry on the relay PCA watches the status of D1. Should this LED ever stay ON or OFF for 30 seconds (indicating that the CPU or I²C bus has stopped functioning) this Watchdog Circuit automatically shuts all valves and turns off all heaters and lamps.

9.2.4. MOTHERBOARD

This is the largest electronic assembly in the calibrator and is mounted to the rear panel as the base for the CPU board and all I/O connectors. This printed circuit assembly provides a multitude of functions including A/D conversion, digital input/output, PC-104 to I²C translation, temperature sensor signal processing and is a pass through for the RS-232 and RS-485 signals.

9.2.4.1. A to D Conversion

Analog signals, such as the voltages received from the calibrator's various sensors, are converted into digital signals that the CPU can understand and manipulate by the analog to digital converter (A/D). Under the control of the CPU, this functional block selects a particular signal input and then converts the selected voltage into a digital word.

The A/D consists of a voltage-to-frequency (V-F) converter, a programmable logic device (PLD), three multiplexers, several amplifiers and some other associated devices. The V-F converter produces a frequency proportional to its input voltage. The PLD counts the output of the V-F converter during a specified time period, and sends the result of that count, in the form of a binary number, to the CPU.

The A/D can be configured for several different input modes and ranges but in this calibrator it is used in uni-polar mode with a +5V full scale. The converter includes a 1% over and under-range. This allows signals from -0.05V to +5.05V to be fully converted.

For calibration purposes, two reference voltages are supplied to the A/D converter: Reference ground and +4.096 VDC. During calibration, the device measures these two voltages, outputs their digital equivalent to the CPU. The CPU uses these values to compute the converter's offset and slope and also uses these factors for subsequent conversions.

9.2.4.2. Sensor Inputs

The key analog sensor signals are coupled to the A/D converter through the master multiplexer from two connectors on the motherboard. Terminating resistors (100 k Ω) on each of the inputs prevent cross talk between the sensor signals.

9.2.4.3. Thermistor Interface

This circuit provides excitation, termination and signal selection for several negative-coefficient, thermistors (temperature sensors) located inside the calibrator.

9.2.4.4. Analog Outputs

The calibrator comes equipped with one analog output. It can be set by the user to carry the current signal level of any one of the parameters (see Table 7-4) and will output an analog VDC signal that rises and falls in relationship with the value of the parameter.

9.2.4.5. External Digital I/O

The external digital I/O performs two functions.

The **STATUS** outputs carry logic-level (5V) signals through an optically isolated 8-pin connector on the rear panel of the calibrator. These outputs convey on/off information about certain calibrator conditions such as **CONC VALID**. They can be used to interface with certain types of programmable devices.

The **CONTROL** outputs can be used to initiate actions by external peripheral devices in conjunction with individual steps of a calibration sequence (see Section 6.5.1.6).

The **CONTROL** inputs can be initiated by applying 5V DC power from an external source such as a PLC or data logger (Section 6.5.1.5). Zero and span calibrations can be initiated by contact closures on the rear panel.

9.2.4.6. I²C Data Bus

I²C is a two-way, clocked, bi-directional, digital serial I/O bus that is used widely in commercial and consumer electronic systems. A transceiver on the motherboard converts data and control signals from the PC-104 bus to I²C. The data is then fed to the relay board, optional analog input board and valve driver board circuitry.

9.2.4.7. Power-up Circuit

This circuit monitors the +5V power supply during calibrator start-up and sets the analog outputs, external digital I/O ports, and I²C circuitry to specific values until the CPU boots and the instrument software can establish control.

9.2.5. POWER SUPPLY AND CIRCUIT BREAKER

The calibrator operates in two main AC power ranges: 100-120 VAC and 220-240 VAC (both $\pm 10\%$) between 47 and 63 Hz. A 5 ampere circuit breaker is built into the ON/OFF switch. In case of a wiring fault or incorrect supply power, the circuit breaker will automatically turn off the calibrator.

NOTE:

The calibrator is equipped with a universal power supply that allows it to accept any AC power configuration, within the limits specified in Table 2-2.



CAUTION

Should the power circuit breaker trip, correct the condition causing this situation before turning the calibrator back on.

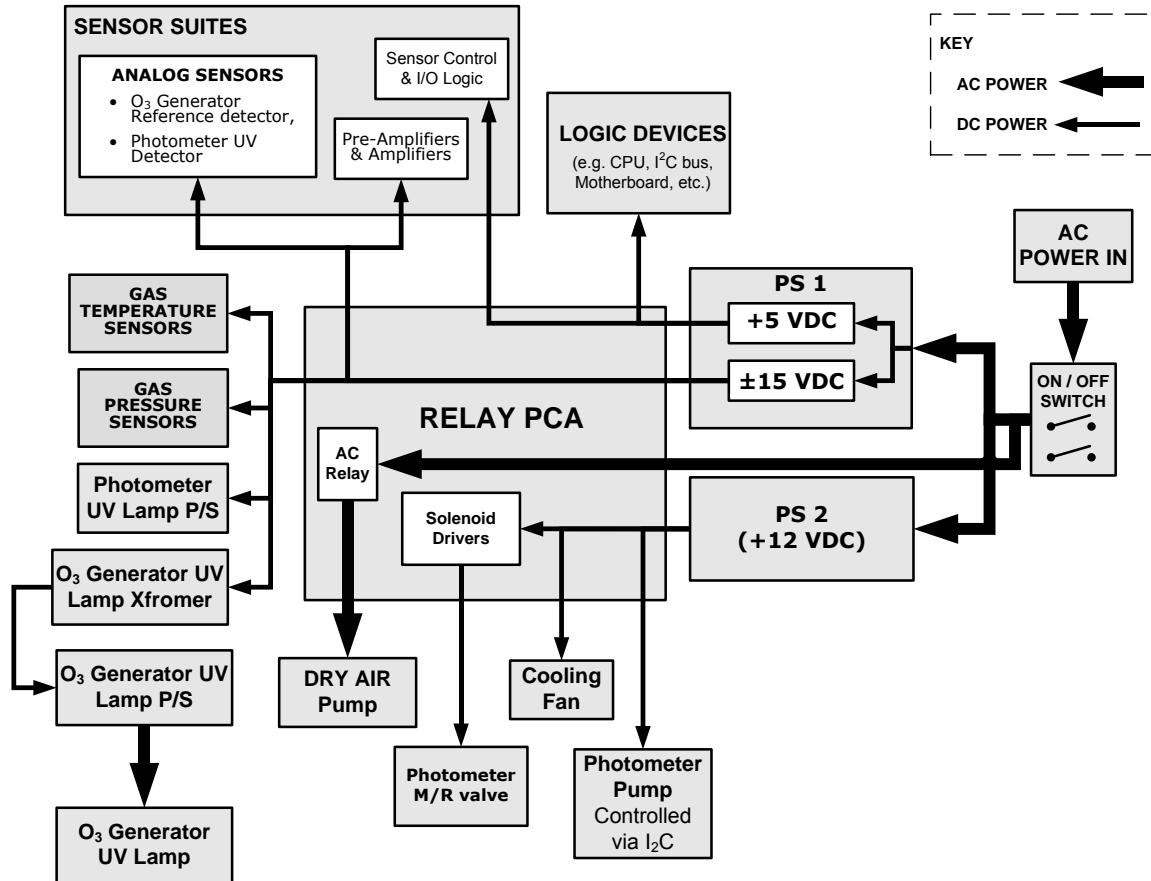

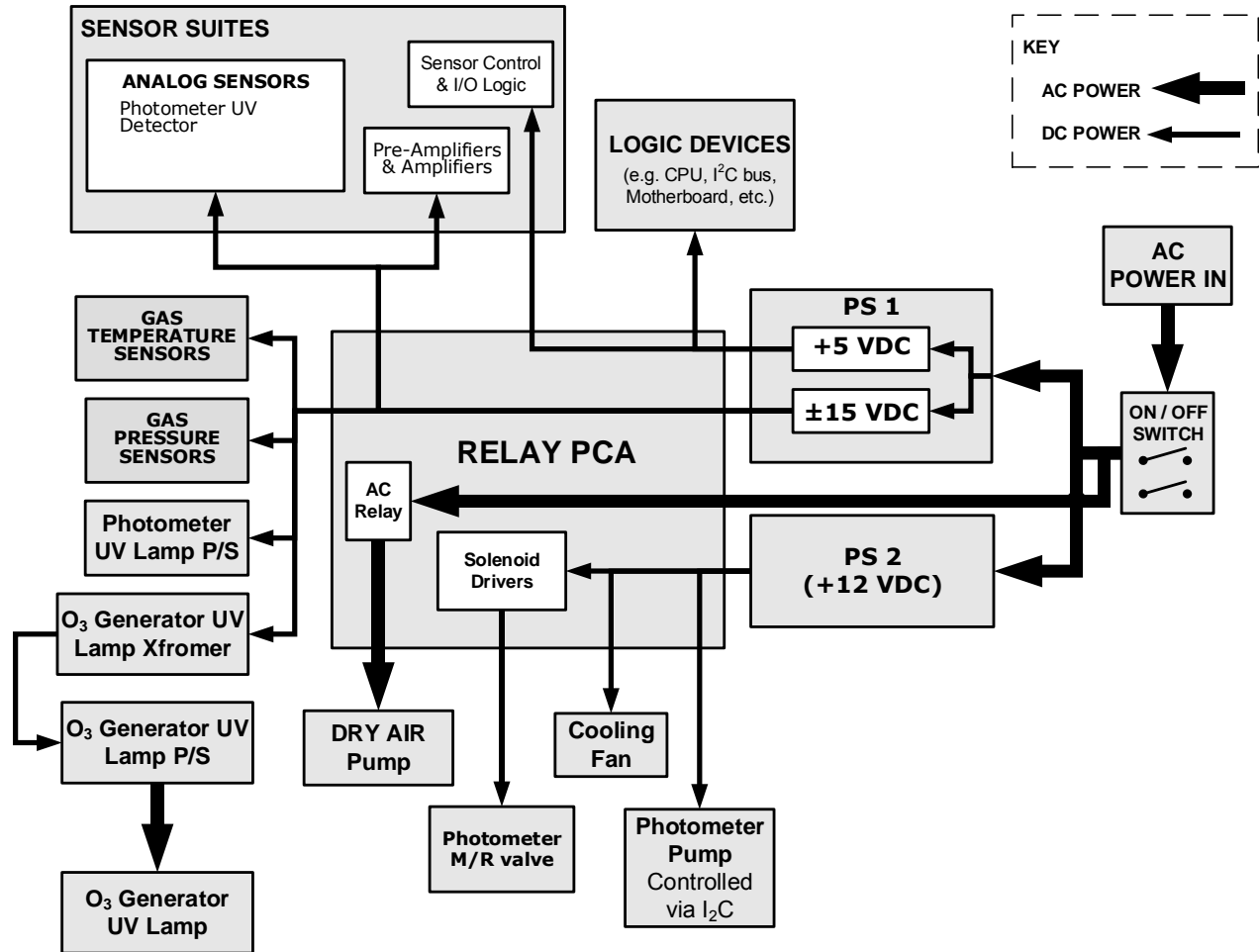

Figure 9-8: Power Distribution Block diagram

9.2.6. AC POWER CONFIGURATION

The digital electronic systems will operate with any of the specified power regimes. As long as instrument is connected to 100-120 VAC or 220-240 VAC at either 50 or 60 Hz it will turn on and after about 30 seconds show a front panel display. Internally, the status LEDs located on the Relay PCA, Motherboard and CPU should turn on as soon as the power is supplied.

On the other hand, in some of the calibrators the dry air pump must be properly configured for the type of power being supplied to the instrument. Figure 2-3 shows the location of the Pump AC Configuration jumper.

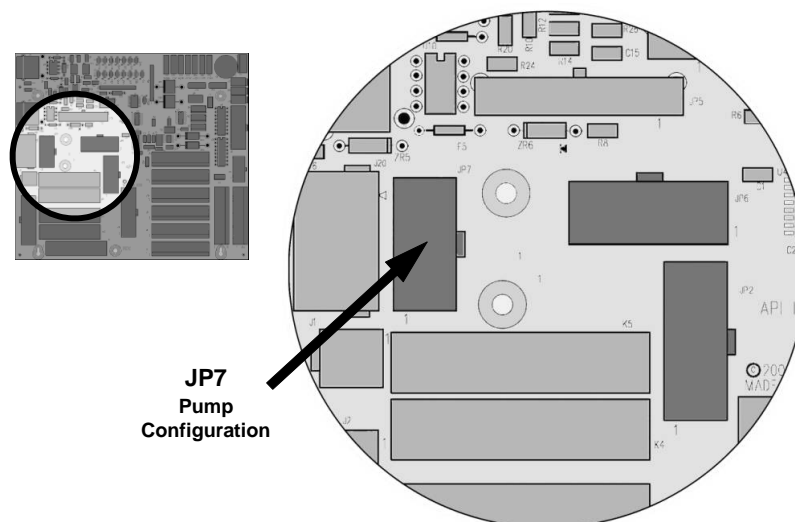

Figure 9-9: Location of the AC Configuration Jumper for the Dry Air Pump

9.2.6.1. AC Configuration – Internal Pump (JP7)

AC power configuration for the internal dry air pump is set using Jumper set JP7.

Table 9-2: AC Power Configuration for Internal Pumps (JP7)

LINE POWER	LINE FREQUENCY	JUMPER COLOR	FUNCTION	JUMPER BETWEEN PINS
110VAC 115 VAC	60 HZ	WHITE	Connects pump pin 3 to 110 / 115 VAC power line	2 to 7
			Connects pump pin 3 to 110 / 115 VAC power line	3 to 8
			Connects pump pins 2 & 4 to Neutral	4 to 9
	50 HZ ¹	BLACK	Connects pump pin 3 to 110 / 115 VAC power line	2 to 7
			Connects pump pin 3 to 110 / 115 VAC power line	3 to 8
			Connects pump pins 2 & 4 to Neutral	4 to 9
220VAC 240 VAC	60 HZ	BROWN	Connects pump pins 3 and 4 together	1 to 6
			Connects pump pin 1 to 220 / 240VAC power line	3 to 8
	50 HZ ¹	BLUE	Connects pump pins 3 and 4 together	1 to 6
			Connects pump pin 1 to 220 / 240VAC power line	3 to 8

¹ A jumper between pins 5 and 10 may be present on the jumper plug assembly, but is only functional on the T300 and has no function on the Models T700 or T703.

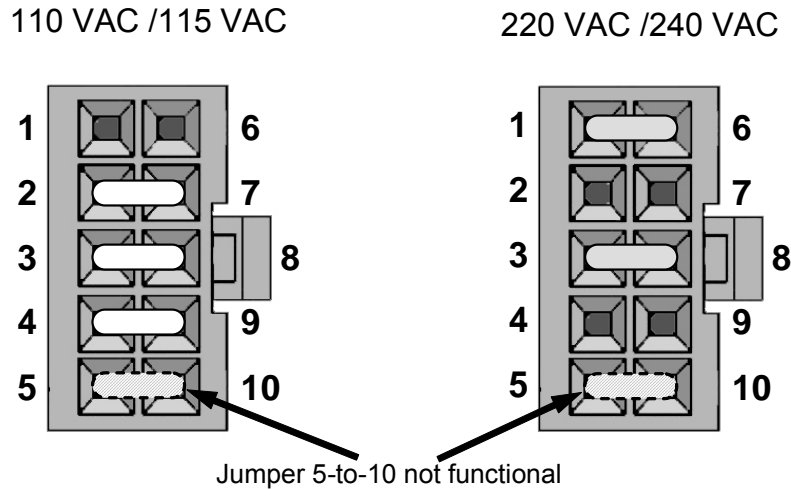

Figure 9-10: Pump AC Power Jumpers (JP7)

9.3. FRONT PANEL TOUCHSCREEN/DISPLAY INTERFACE

The most commonly used method for communicating with the T703/T703U Dynamic Dilution Calibrator is via the instrument's front panel LCD touchscreen display. The LCD display is controlled directly by the CPU board. The touchscreen is interfaced to the CPU by means of a touchscreen controller that connects to the CPU via the internal USB bus and emulates a computer mouse.

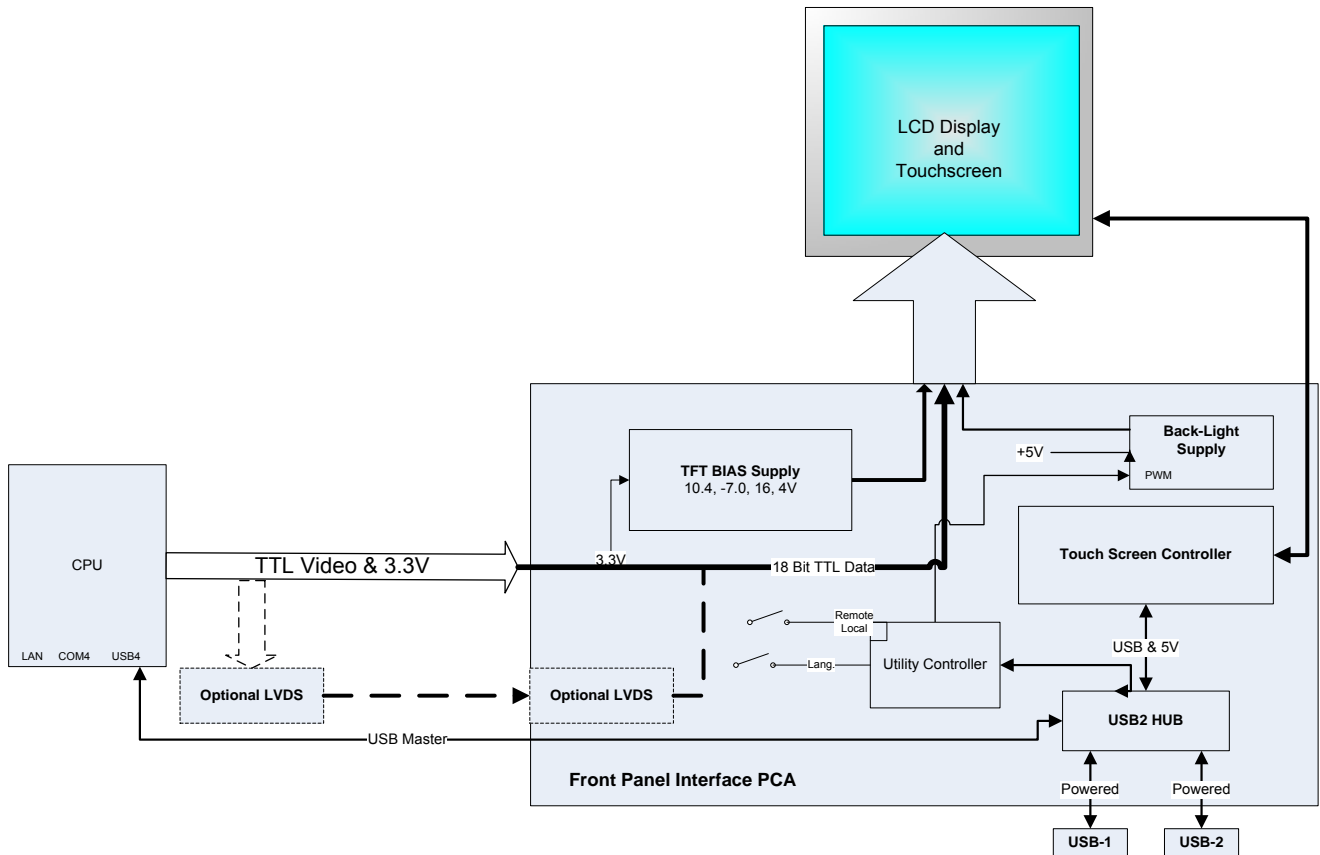

Figure 9-11: Front Panel Layout

The LCD display is controlled directly by the CPU board. The touchscreen is interfaced to the CPU by means of a touchscreen controller that connects to the CPU via the internal USB bus and emulates a computer mouse.

9.3.1.1. Front Panel Interface PCA

The front panel interface PCA controls the various functions of the display and touchscreen. For driving the display it provides connection between the CPU video controller and the LCD display module. This PCA also contains:

- power supply circuitry for the LCD display module
- a USB hub that is used for communications with the touchscreen controller and the two front panel USB device ports
- the circuitry for powering the display backlight

9.4. SOFTWARE OPERATION

The calibrator's core module is a high performance, Vortex 86SX-based microcomputer running Windows CE. Inside Windows CE, special software developed by Teledyne API interprets user commands from the various interfaces, performs procedures and tasks, stores data in the CPU's various memory devices, and calculates the concentration of the gas being sampled.

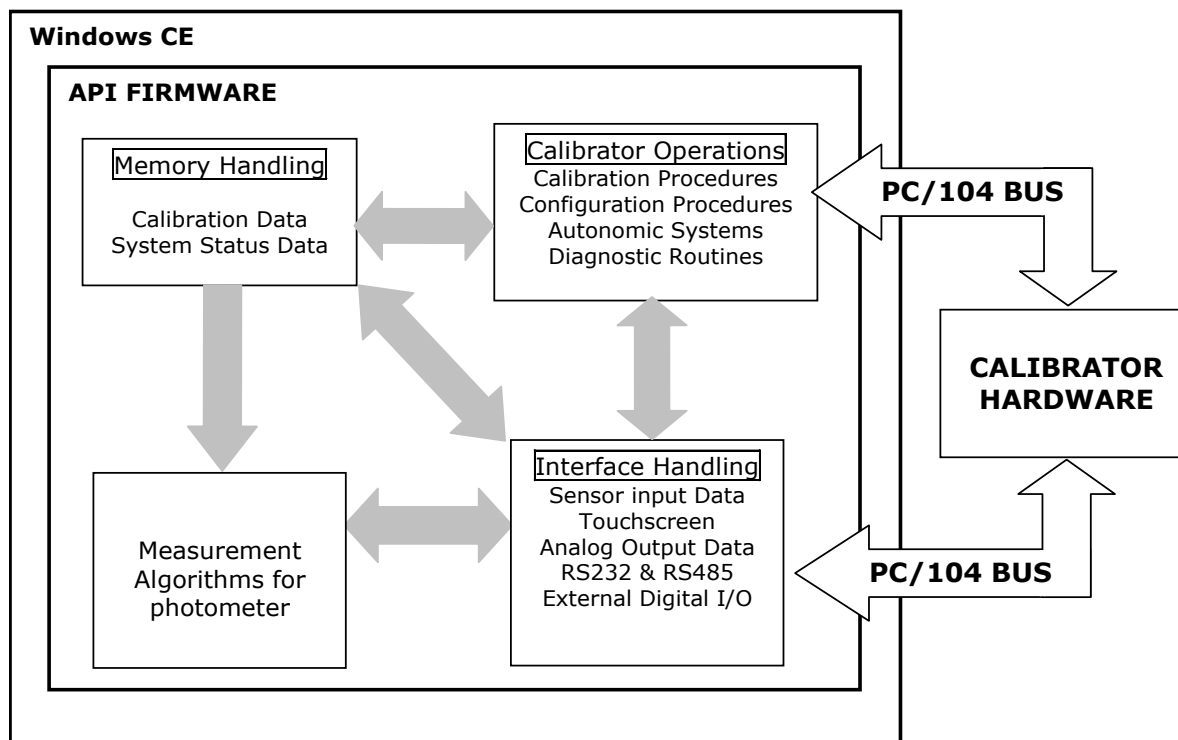

Figure 9-12: Schematic of Basic Software Operation

9.5. O₃ GENERATOR OPERATION

9.5.1. PRINCIPLE OF PHOTOLYTIC O₃ GENERATION

Ozone is a naturally occurring substance that is sometimes called "activated oxygen". It contains three atoms of oxygen (O₃) instead of the usual two found in normal oxygen (O₂) that is essential for life. Because of its relatively short half-life, ozone cannot be bottled and stored for later use and therefore must always be generated on-site by an ozone generator. The two main principles of ozone generation are UV-light and corona discharge. While the corona-discharge method is most common because of its ability to generate very high concentrations (up to 50%), it is inappropriate for calibration needs since the level of fine control over the O₃ concentration is poor. Also, the corona discharge method produces a small amount of NO₂ as a byproduct, which also may be undesirable in a calibration application.

The UV-light method is most feasible in calibration application where production of low, accurate concentrations of ozone is desired. This method mimics the radiation method that occurs naturally from the sun in the upper atmosphere producing the ozone layer. An ultra-violet lamp inside the generator emits a precise wavelength of UV Light (185 nm). Ambient air is passed over an ultraviolet lamp, which splits some of the molecular oxygen (O₂) in the gas into individual oxygen atoms which attach to other existing oxygen molecules (O₂), forming ozone (O₃).

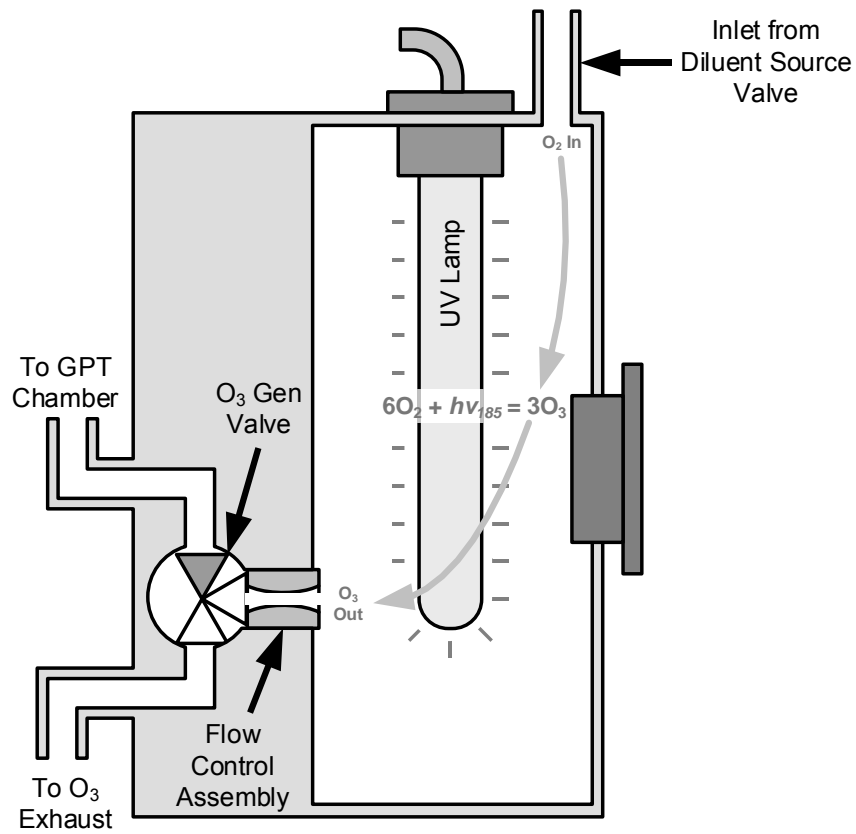

Figure 9-13: O₃ Generator Internal Pneumatics

9.5.2. GENERATOR PNEUMATIC OPERATION

The rate of flow through the O₃ generator is controlled by a flow control assembly located on the Regulator Sub-Assembly in the front of the calibrator.

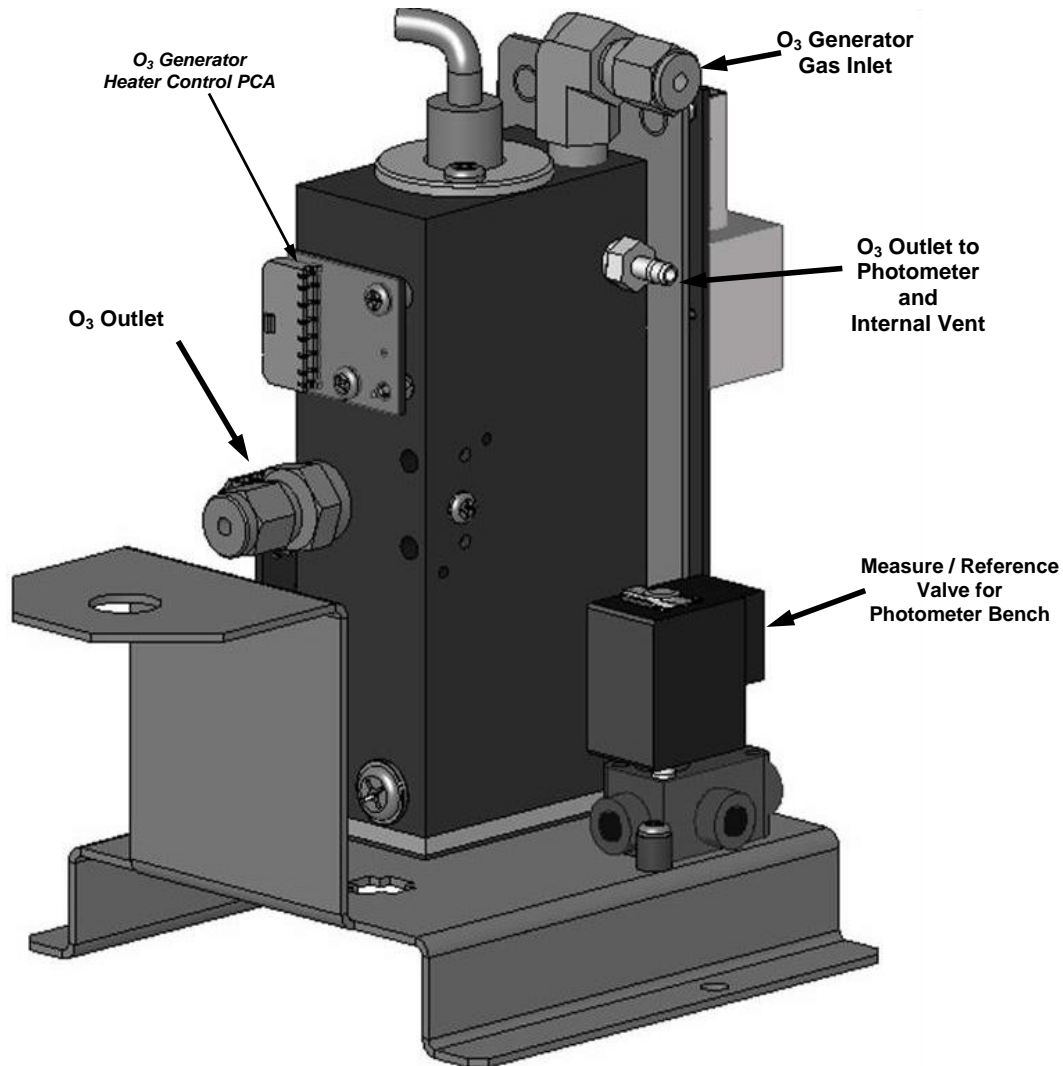

Figure 9-14: O₃ Generator Valve and Gas Fixture Locations

9.5.3. O₃ GENERATOR ELECTRONIC OPERATION

Electronically the O₃ generator and its subcomponents act as peripheral devices operated by the CPU via the motherboard. Sensor signals, such as the UV lamp thermistor are routed to the motherboard, where they are digitized. Digital data is sent by the motherboard to the calibrator's CPU and where required stored in either flash memory or on the CPU's disk-on-chip. Commands from the CPU are sent to the motherboard and forwarded to the various devices via the calibrator's I²C bus.

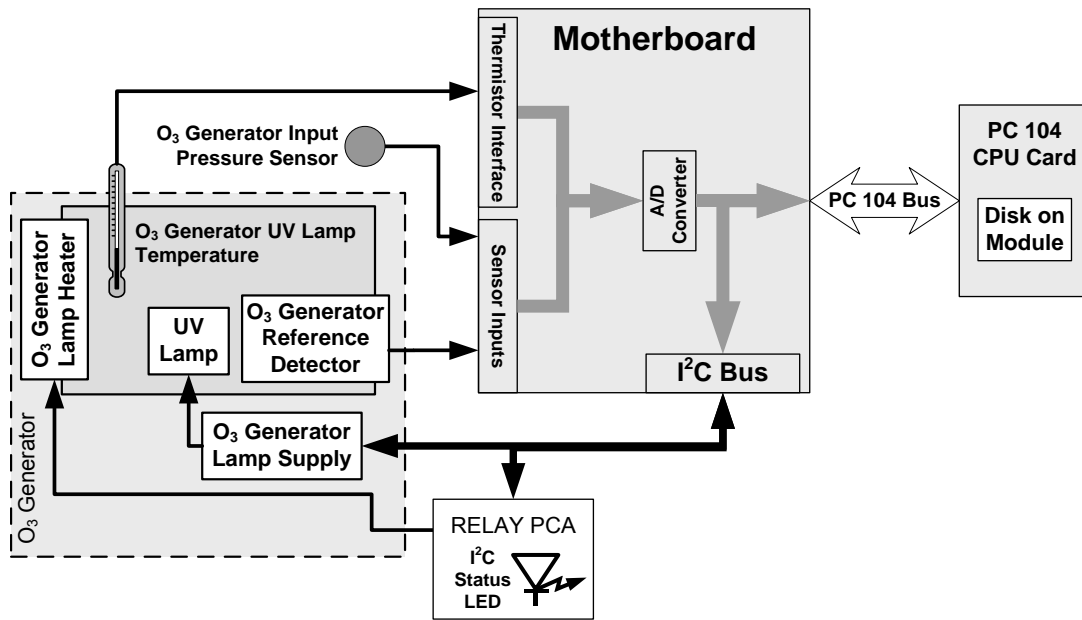

Figure 9-15: O₃ Generator Electronic Block Diagram

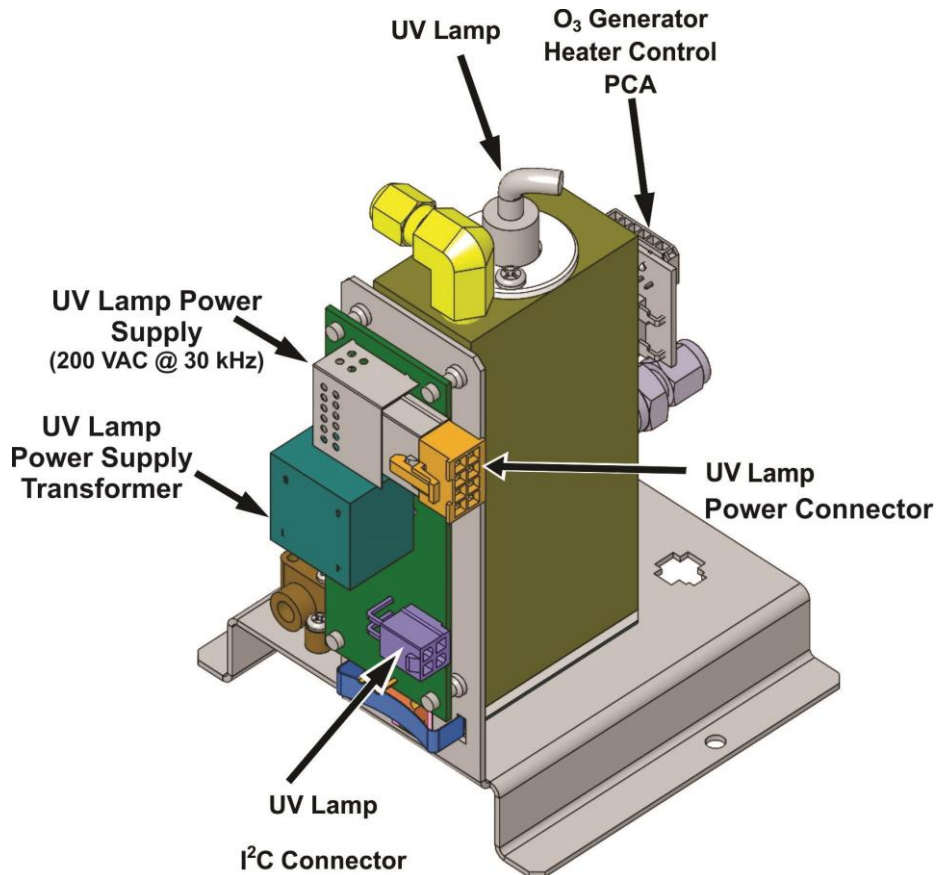

Figure 9-16: O₃ Generator Electronic Components Location

9.5.3.1. O₃ Generator Temperature Control

In order to operate at peak efficiency the UV lamp of the O₃ generator is maintained at a constant 48°C. If the lamp temperature falls below 43°C or rises above 53°C a warning is issued by the CPU.

This temperature is controlled as described in the section on the relay PCA (see Section 9.2.3.2). The location of the thermistor and heater associated with the O₃ generator is shown below:

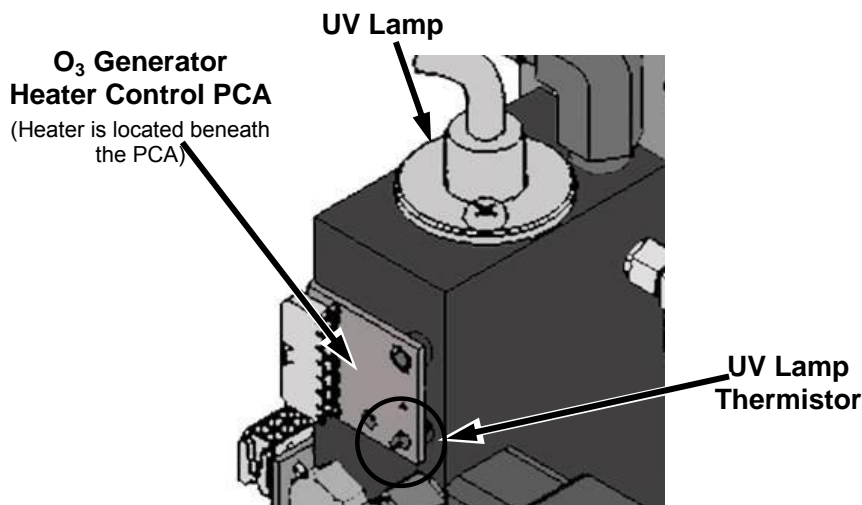

Figure 9-17: O₃ Generator Temperature Thermistor and DC Heater Locations

9.6. PHOTOMETER OPERATION

The calibrator's photometer determines the concentration of Ozone (O₃) in a sample gas drawn through it. Sample and calibration gasses must be supplied at ambient atmospheric pressure in order to establish a stable gas flow through the absorption tube where the gas' ability to absorb ultraviolet (UV) radiation of a certain wavelength (in this case 254 nm) is measured.

Gas bearing O₃ and zero air are alternately routed through the photometer's absorption tube. Measurements of the UV light passing through the sample gas with and without O₃ present are made and recorded.

Calibration of the photometer is performed in software and does not require physical adjustments. Two internal variables, a slope and offset are used to adjust the calibration of the photometer.

The CPU uses these calibration values, the UV absorption measurements made on the sample gas in the absorption tube along with data regarding the current temperature and pressure of the gas to calculate a final O₃ concentration.

9.6.1. MEASUREMENT METHOD

9.6.1.1. Calculating O₃ Concentration

The basic principle by which photometer works is called Beer's Law (also referred to as the Beer-Lambert equation). It defines the how light of a specific

wavelength is absorbed by a particular gas molecule over a certain distance at a given temperature and pressure. The mathematical relationship between these three parameters for gasses at Standard Temperature and Pressure (STP) is:

Equation 9-5

$$I = I_o e^{-\alpha LC} \quad \text{at STP}$$

Where:

I_o is the intensity of the light if there was no absorption.

I is the intensity with absorption.

L is the absorption path, or the distance the light travels as it is being absorbed.

C is the concentration of the absorbing gas. In the case of the Model T703, Ozone (O_3).

α is the absorption coefficient that tells how well O_3 absorbs light at the specific wavelength of interest.

To solve this equation for **C** , the concentration of the absorbing Gas (in this case O_3), the application of a little algebra is required to rearrange the equation as follows:

Equation 9-6

$$C = \ln\left(\frac{I_o}{I}\right) \times \left(\frac{1}{\alpha L}\right) \quad \text{at STP}$$

Unfortunately, both ambient temperature and pressure influence the density of the sample gas and therefore the number of ozone molecules present in the absorption tube thus changing the amount of light absorbed.

In order to account for this effect the following addition is made to the equation:

Equation 9-7

$$C = \ln\left(\frac{I_o}{I}\right) \times \left(\frac{1}{\alpha L}\right) \times \left(\frac{T}{273 \text{ K}} \times \frac{29.92 \text{ inHg}}{P}\right)$$

Where:

T = sample ambient temperature in degrees Kelvin

P = ambient pressure in inches of mercury

Finally, to convert the result into Parts per Billion (PPB), the following change is made:

Equation 9-8

$$C = \ln\left(\frac{I_o}{I}\right) \times \left(\frac{10^9}{\alpha L}\right) \times \left(\frac{T}{273 \text{ K}} \times \frac{29.92 \text{ inHg}}{P}\right)$$

In a nutshell the photometer:

- Measures each of the above variables: ambient temperature; ambient gas pressure; the intensity of the UV light beam with and without O₃ present;
- Inserts know values for the length of the absorption path and the absorption coefficient, and:
- Calculates the concentration of O₃ present in the sample gas.

9.6.1.2. The Measurement / Reference Cycle

In order to solve the Beer-Lambert equation it is necessary to know the intensity of the light passing through the absorption path both when O₃ is present and when it is not. A valve called the measure/reference valve, physically located on front-left corner of the O₃ generator assembly (see Figures 3-4 and 9-14) alternates the gas stream flowing to the photometer between zero air (diluent gas) and the O₃ output from the O₃ generator. This cycle takes about 6 seconds.

Table 9-3: Photometer Measurement / Reference Cycle

TIME INDEX	STATUS
0 sec.	Measure/Reference Valve Opens to the Measure Path.
0 – 2 sec.	Wait Period. Ensures that the Absorption tube has been adequately flushed of any previously present gasses.
2 – 3 sec.	Analyzer measures the average UV light intensity of O ₃ bearing Sample Gas (I) during this period.
3 sec.	Measure/Reference Valve Opens to the Reference Path.
3 – 5 sec.	Wait Period. Ensures that the Absorption tube has been adequately flushed of O ₃ bearing gas.
5 – 6 sec.	Analyzer measures the average UV light intensity of Non-O ₃ bearing Sample Gas (I₀) during this period.
CYCLE REPEAT EVERY 6 SECONDS	

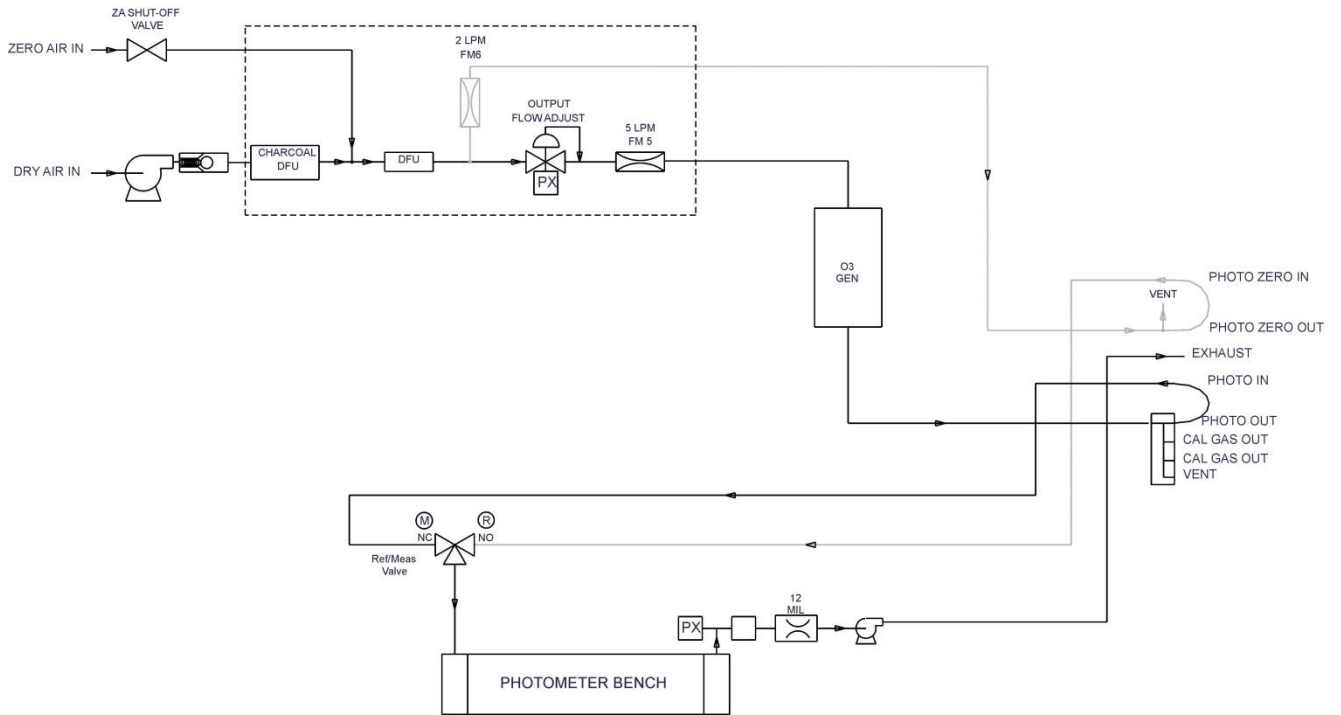

Figure 9-18: T703 O₃ Photometer Gas Flow – Measure Cycle

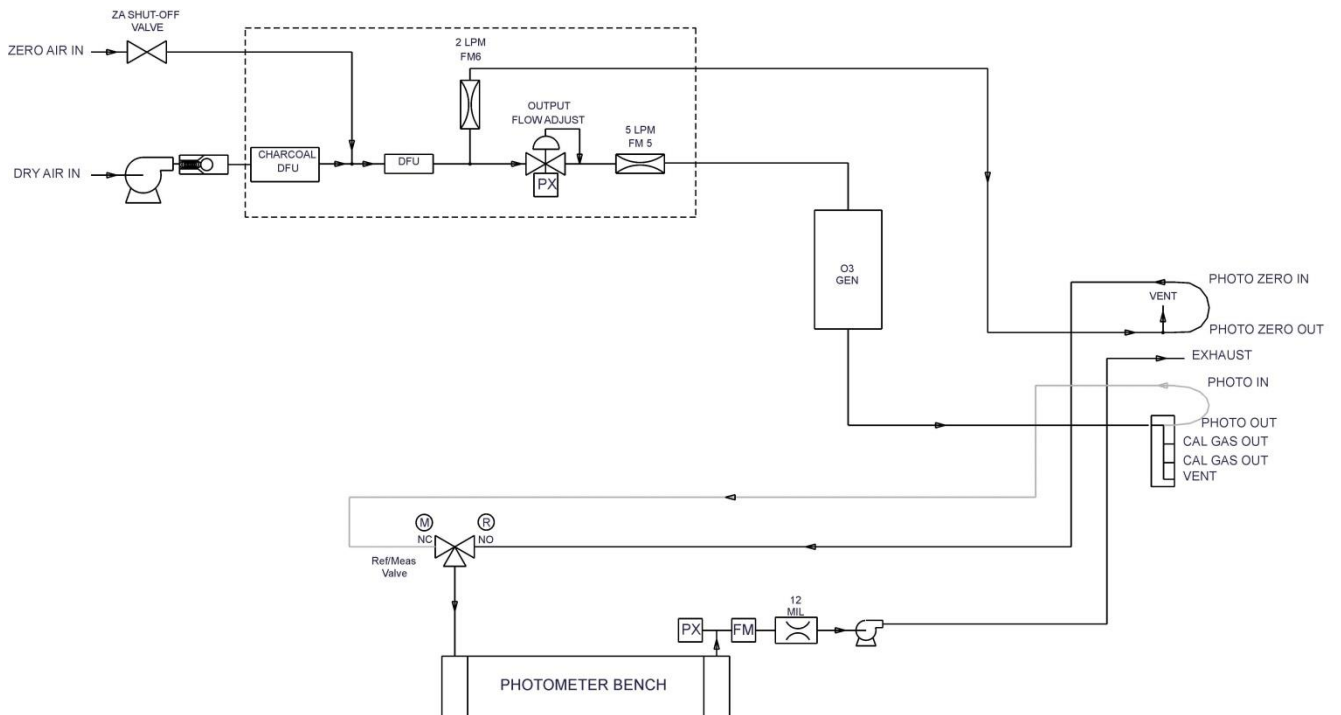

Figure 9-19: T703 O₃ Photometer Gas Flow – Reference Cycle

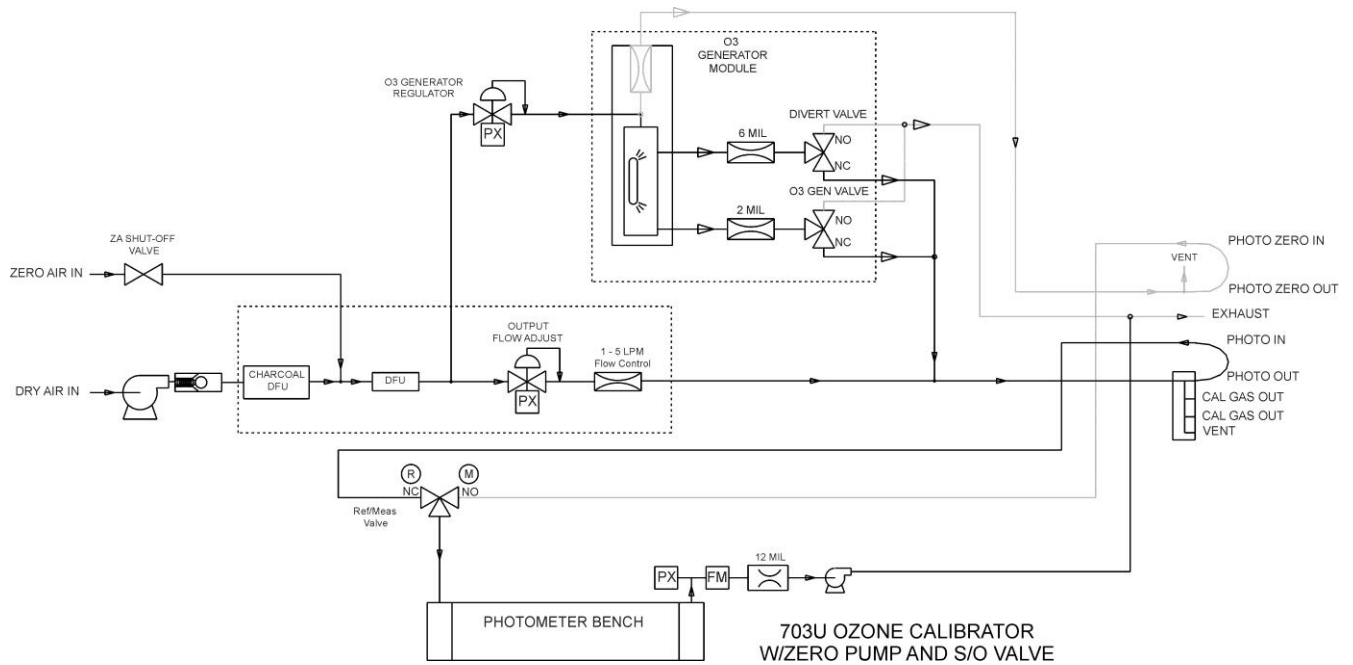

Figure 9-20: T703U O₃ Photometer Gas Flow – Measure Cycle

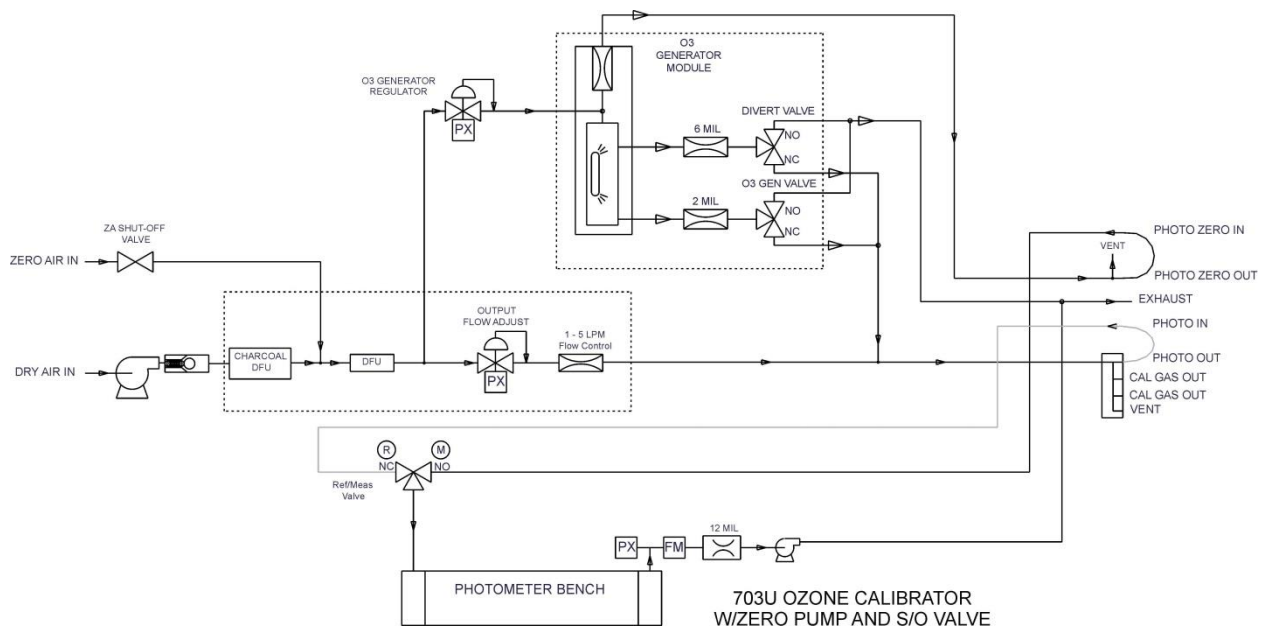

Figure 9-21: T703U O₃ Photometer Gas Flow – Reference Cycle

9.6.1.3. The Absorption Path

In the most basic terms, the photometer uses a high energy, mercury vapor lamp to generate a beam of UV light. This beam passes through a window of material specifically chosen to be both non-reactive to O₃ and transparent to UV radiation at 254nm and into an absorption tube filled with sample gas.

Because ozone is a very efficient absorber of UV radiation the absorption path length required to create a measurable decrease in UV intensity is short enough (approximately 42 cm) that the light beam is only required to make one pass

through the Absorption Tube. Therefore, no complex mirror system is needed to lengthen the effective path by bouncing the beam back and forth.

Finally, the UV passes through a similar window at the other end of the absorption tube and is detected by a specially designed vacuum diode that only detects radiation at or very near a wavelength of 254nm. The specificity of the detector is high enough that no extra optical filtering of the UV light is needed.

The detector reacts to the UV light and outputs a current signal that varies in direct relationship with the intensity of the light shining on it. This current signal is amplified and converted to a 0 to 5 VDC voltage analog signal voltage sent to the instrument's motherboard where it is digitized. The CPU to be uses this digital data in computing the concentration of O₃ in the absorption tube.

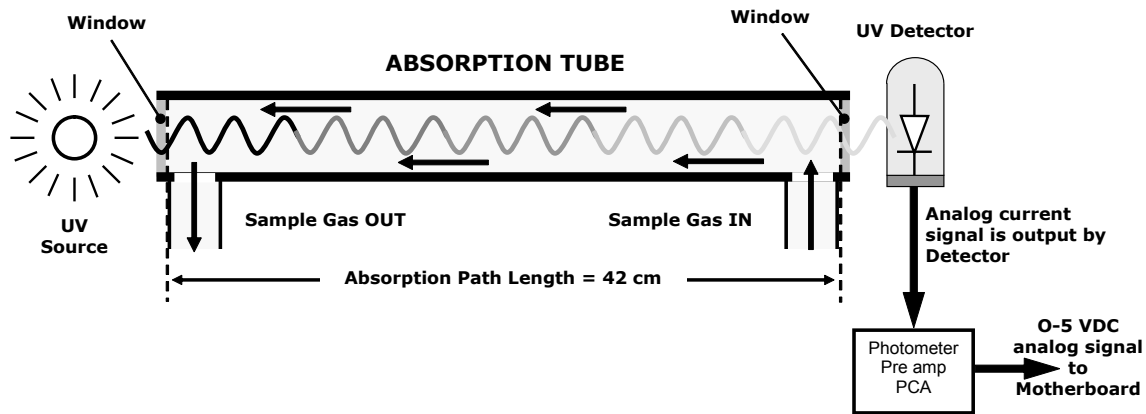

Figure 9-22: O₃ Photometer Absorption Path

9.6.1.4. Interferent Rejection

It should be noted that the UV absorption method for detecting ozone is subject to interference from a number of sources. The photometer has been successfully tested for its ability to reject interference from sulfur dioxide, nitrogen dioxide, nitric oxide, water, and meta-xylene.

While the photometer rejects interference from the aromatic hydrocarbon meta-xylene, it should be noted that there are a very large number of other volatile aromatic hydrocarbons that could potentially interfere with ozone detection. If the calibrator is installed in an environment where high aromatic hydrocarbon concentrations are suspected, specific tests should be conducted to reveal the amount of interference these compounds may be causing.

9.6.2. PHOTOMETER LAYOUT

The Photometer is where the absorption of UV light by ozone is measured and converted into a voltage. It consists of several sub-assemblies:

- A mercury-vapor UV lamp. This lamp is coated in a material that optically screens the UV radiation output to remove the O₃ producing 185nm radiation. Only light at 254nm is emitted.
- An AC power supply that supplies the current for starting and maintaining the plasma arc of the mercury vapor lamp.

- A thermistor and DC heater attached to the UV Lamp to maintain the Lamp at an optimum operating temperature.
- 42 cm long quartz absorption tube.
- A thermistor attached to the quartz tube for measuring sample gas temperature.
- Gas inlet and outlet mounting blocks that rout sample gas into and out of the photometer.
- The vacuum diode, UV detector that converts UV light to a DC current.
- A preamplifier assembly, which convert the Detector's current output into a DC Voltage then amplifies it to a level readable by the A to D converter circuitry of the instrument's motherboard

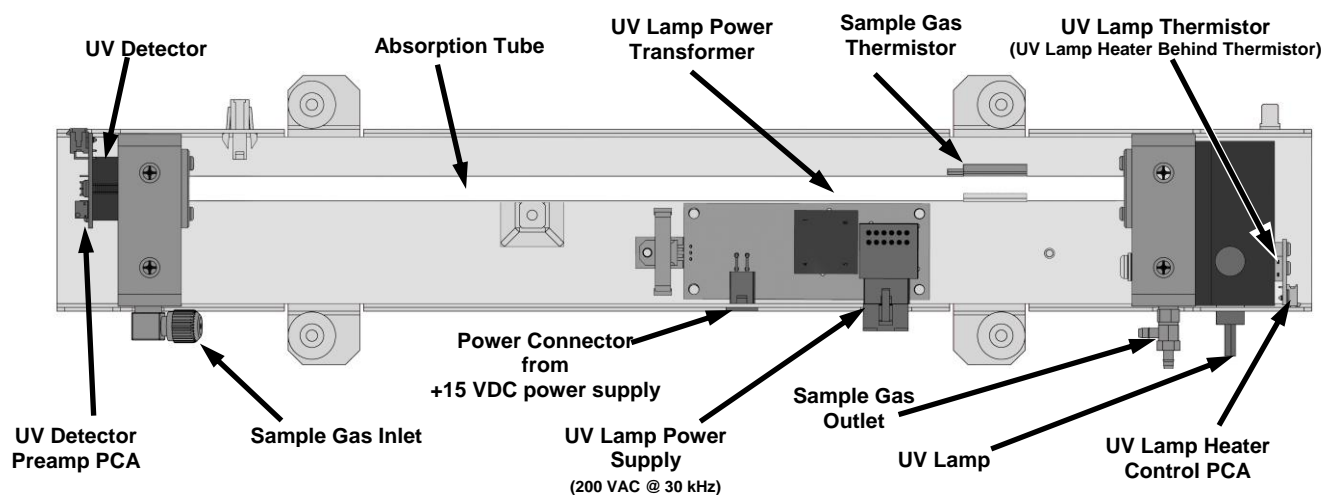

Figure 9-23: O₃ Photometer Layout – Top Cover Removed

9.6.3. PHOTOMETER PNEUMATIC OPERATION

The flow of gas through the photometer is created by a small internal pump that pulls air through the instrument. There are several advantages to this “pull through” configuration. Placing the pump down stream from the absorption tube avoids problems caused by the pumping process heating and compressing the sample.

In order to measure accurately the presences of low concentrations of O₃ in the sample air it is necessary to establish and maintain a relatively constant and stable volumetric flow of sample gas through the photometer. The simplest way to accomplish this is by placing a flow control assembly containing a critical flow orifice directly upstream of the pump but down stream from the absorption tube.

The critical flow orifice installed in the pump supply line is tuned to create a gas flow of 800 cm³/min. A pressure sensor and a flow sensor, located on the O₃ generator / photometer pressure flow sensor PCA, monitor the pressure and flow rate of the gas passing through the photometers absorption tube.

See Figure 9-18 through Figure 9-22 for depictions of the gas flow related to the photometer.

9.6.4. PHOTOMETER ELECTRONIC OPERATION

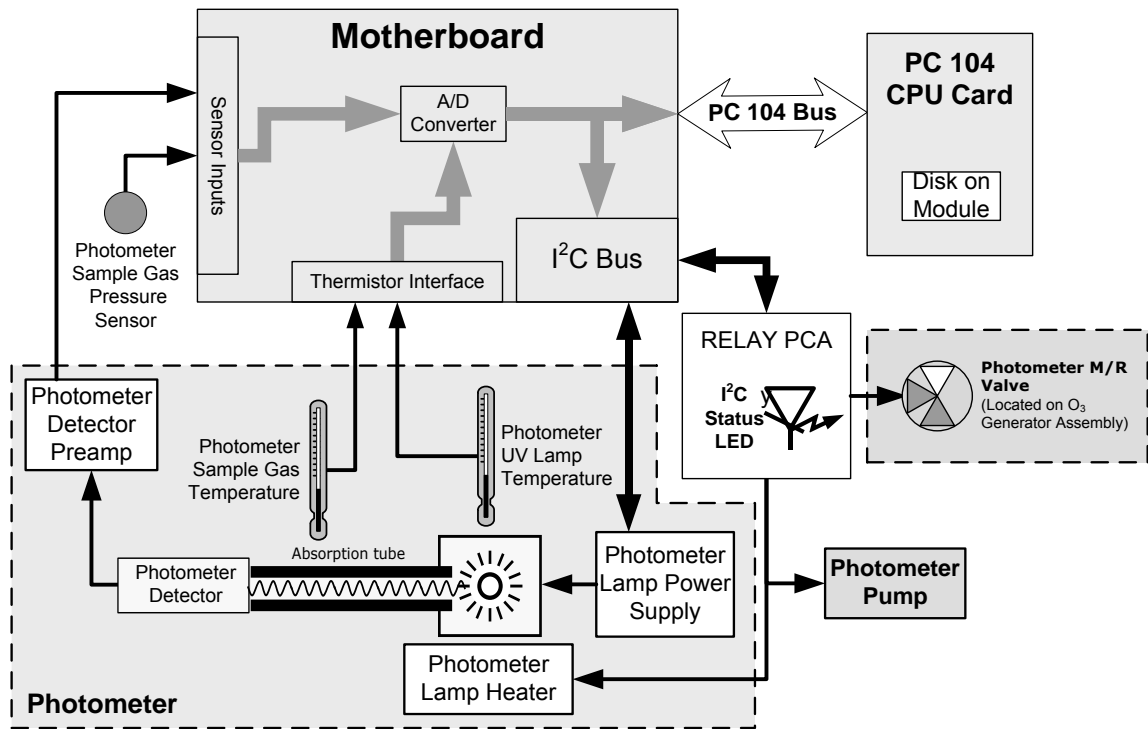

Figure 9-24: O₃ Photometer Electronic Block Diagram

Like the O₃ generator, the O₃ photometer and its subcomponents act as peripheral devices operated by the CPU via the motherboard. Communications to and from the CPU are handled by the motherboard.

Outgoing commands for the various devices such as the photometer pump, the UV lamp power supply the UV Lamp heater are issued via the I²C bus to circuitry on the relay PCA which turns them ON/OFF. The CPU also issues commands over the I²C bus that cause the relay PCA to cycle the measure/reference valve back and forth.

Incoming data the UV light detector is amplified locally then converted to digital information by the motherboard. Output from the photometers temperature sensors is also amplified and converted to digital data by the motherboard. The O₃ concentration of the sample gas is computed by the CPU using this data (along with gas pressure and flow data received from the pressure sensors).

9.6.4.1. O₃ Photometer Temperature Control

In order to operate at peak efficiency the UV lamp of the O₃ photometer is maintained at a constant 58°C. This is intentionally set at a temperature higher than the ambient temperature of the operating environment to make sure that local changes in temperature do not affect the UV Lamp. If the lamp temperature falls below 56°C or rises above 61°C a warning is issued by the calibrator's CPU.

This temperature is controlled as described in the section on the relay PCA (Section 9.2.3.2).

The following TEST functions report these temperatures and are viewable from the instrument's front panel:

- **PHOTO LAMP TEMP** - The temperature of the UV Lamp reported in °C.
- **PHOTO STEMP** - The temperature of the Sample gas in the absorption tube reported in °C.

9.6.4.2. Pneumatic Sensors for the O₃ Photometer

The several sensors located on the pneumatic sensor just to the left rear of the O₃ generator assembly measure the absolute pressure and the flow rate of gas inside the photometer's absorption tube. This information is used by the CPU to calculate the O₃ concentration of the sample gas (See Equation 9-7). Both of these measurements are made downstream from the absorption tube but upstream of the pump. A critical flow orifice located between the flow sensor and the pump maintains the gas flow through the photometer at 800 cm³/min.

The following TEST functions are viewable from the instrument's front panel:

- **PHOTO FLOW** - The flow rate of gas through the photometer measured in LPM.
- **PHOTO SPRESS** – the pressure of the gas inside the absorption tube. This pressure is reported in inches of mercury-absolute (**in-Hg-A**), i.e. referenced to a vacuum (zero absolute pressure). This is not the same as **PSIG**.

GLOSSARY

Note: Some terms in this glossary may not occur elsewhere in this manual.

Term	Description/Definition
10BaseT	an Ethernet standard that uses twisted ("T") pairs of copper wires to transmit at 10 megabits per second (Mbps)
100BaseT	same as 10BaseT except ten times faster (100 Mbps)
APICOM	name of a remote control program offered by Teledyne-API to its customers
ASSY	<i>Assembly</i>
CAS	<i>Code-Activated Switch</i>
CD	<i>Corona Discharge</i> , a frequently luminous discharge, at the surface of a conductor or between two conductors of the same transmission line, accompanied by ionization of the surrounding atmosphere and often by a power loss
CE	<i>Converter Efficiency</i> , the percentage of light energy that is actually converted into electricity
CEM	<i>Continuous Emission Monitoring</i>
Chemical formulas that may be included in this document:	
CO ₂	carbon dioxide
C ₃ H ₈	propane
CH ₄	methane
H ₂ O	water vapor
HC	general abbreviation for hydrocarbon
HNO ₃	nitric acid
H ₂ S	hydrogen sulfide
NO	nitric oxide
NO ₂	nitrogen dioxide
NO _x	nitrogen oxides, here defined as the sum of NO and NO ₂
NO _y	nitrogen oxides, often called odd nitrogen: the sum of NO _x plus other compounds such as HNO ₃ (definitions vary widely and may include nitrate (NO ₃), PAN, N ₂ O and other compounds as well)
NH ₃	ammonia
O ₂	molecular oxygen
O ₃	ozone
SO ₂	sulfur dioxide
cm ³	metric abbreviation for <i>cubic centimeter</i> (replaces the obsolete abbreviation "cc")
CPU	<i>Central Processing Unit</i>
DAC	<i>Digital-to-Analog Converter</i>
DAS	<i>Data Acquisition System</i>
DCE	<i>Data Communication Equipment</i>
DFU	<i>Dry Filter Unit</i>
DHCP	<i>Dynamic Host Configuration Protocol</i> . A protocol used by LAN or Internet servers to automatically set up the interface protocols between themselves and any other addressable device connected to the network
DIAG	<i>Diagnostics</i> , the diagnostic settings of the instrument.

Term	Description/Definition
DOM	<i>Disk On Module</i> , a 44-pin IDE flash drive with up to 128MB storage capacity for instrument's firmware, configuration settings and data
DOS	<i>Disk Operating System</i>
DRAM	<i>Dynamic Random Access Memory</i>
DR-DOS	<i>Digital Research DOS</i>
DTE	<i>Data Terminal Equipment</i>
EEPROM	<i>Electrically Erasable Programmable Read-Only Memory</i> also referred to as a FLASH chip or drive
ESD	<i>Electro-Static Discharge</i>
ETEST	<i>Electrical Test</i>
Ethernet	a standardized (IEEE 802.3) computer networking technology for local area networks (LANs), facilitating communication and sharing resources
FEP	<i>Fluorinated Ethylene Propylene</i> polymer, one of the polymers that Du Pont markets as <i>Teflon</i> [®]
Flash	non-volatile, solid-state memory
FPI	<i>Fabry-Perot Interface</i> : a special light filter typically made of a transparent plate with two reflecting surfaces or two parallel, highly reflective mirrors
GFC	<i>Gas Filter Correlation</i>
I ² C bus	a clocked, bi-directional, serial bus for communication between individual instrument components
IC	<i>Integrated Circuit</i> , a modern, semi-conductor circuit that can contain many basic components such as resistors, transistors, capacitors etc in a miniaturized package used in electronic assemblies
IP	<i>Internet Protocol</i>
IZS	<i>Internal Zero Span</i>
LAN	<i>Local Area Network</i>
LCD	<i>Liquid Crystal Display</i>
LED	<i>Light Emitting Diode</i>
LPM	<i>Liters Per Minute</i>
MFC	<i>Mass Flow Controller</i>
M/R	<i>Measure/Reference</i>
MOLAR MASS	the mass, expressed in grams, of 1 mole of a specific substance. Conversely, one mole is the amount of the substance needed for the molar mass to be the same number in grams as the atomic mass of that substance. EXAMPLE: The atomic weight of Carbon is 12 therefore the molar mass of Carbon is 12 grams. Conversely, one mole of carbon equals the amount of carbon atoms that weighs 12 grams. Atomic weights can be found on any Periodic Table of Elements.
NDIR	<i>Non-Dispersive Infrared</i>
NIST-SRM	<i>National Institute of Standards and Technology - Standard Reference Material</i>
PC	<i>Personal Computer</i>
PCA	<i>Printed Circuit Assembly</i> , the PCB with electronic components, ready to use
PC/AT	<i>Personal Computer / Advanced Technology</i>
PCB	<i>Printed Circuit Board</i> , the bare board without electronic component
PFA	<i>Per-Fluoro-Alkoxy</i> , an inert polymer; one of the polymers that Du Pont markets as <i>Teflon</i> [®]

Term	Description/Definition
PLC	<i>Programmable Logic Controller</i> , a device that is used to control instruments based on a logic level signal coming from the instrument
PLD	<i>Programmable Logic Device</i>
PLL	<i>Phase Lock Loop</i>
PMT	<i>Photo Multiplier Tube</i> , a vacuum tube of electrodes that multiply electrons collected and charged to create a detectable current signal
P/N (or PN)	<i>Part Number</i>
PSD	<i>Prevention of Significant Deterioration</i>
PTFE	<i>Poly-Tetra-Fluoro-Ethylene</i> , a very inert polymer material used to handle gases that may react on other surfaces; one of the polymers that <i>Du Pont</i> markets as <i>Teflon</i> [®]
PVC	<i>Poly Vinyl Chloride</i> , a polymer used for downstream tubing
Rdg	Reading
RS-232	specification and standard describing a serial communication method between DTE (Data Terminal Equipment) and DCE (Data Circuit-terminating Equipment) devices, using a maximum cable-length of 50 feet
RS-485	specification and standard describing a binary serial communication method among multiple devices at a data rate faster than RS-232 with a much longer distance between the host and the furthest device
SAROAD	<i>Storage and Retrieval of Aerometric Data</i>
SLAMS	<i>State and Local Air Monitoring Network Plan</i>
SLPM	<i>Standard Liters Per Minute</i> of a gas at standard temperature and pressure
STP	<i>Standard Temperature and Pressure</i>
TCP/IP	<i>Transfer Control Protocol / Internet Protocol</i> , the standard communications protocol for Ethernet devices
TEC	<i>Thermal Electric Cooler</i>
TPC	<i>Temperature/Pressure Compensation</i>
USB	<i>Universal Serial Bus</i> : a standard connection method to establish communication between peripheral devices and a host controller, such as a mouse and/or keyboard and a personal computer or laptop
VARS	<i>Variables</i> , the variable settings of the instrument
V-F	<i>Voltage-to-Frequency</i>
Z/S	<i>Zero / Span</i>

This page intentionally left blank.

APPENDIX A – Software Documentation

APPENDIX A-1: SOFTWARE MENU TREES

APPENDIX A-2: SERIAL I/O SETUP VARIABLES

APPENDIX A-3: WARNINGS AND TEST FUNCTIONS

APPENDIX A-4: SIGNAL I/O DEFINITIONS

APPENDIX A-5: TERMINAL COMMAND DESIGNATORS

APPENDIX A-6: MODBUS REGISTERS

APPENDIX A-1: Software Menu Trees

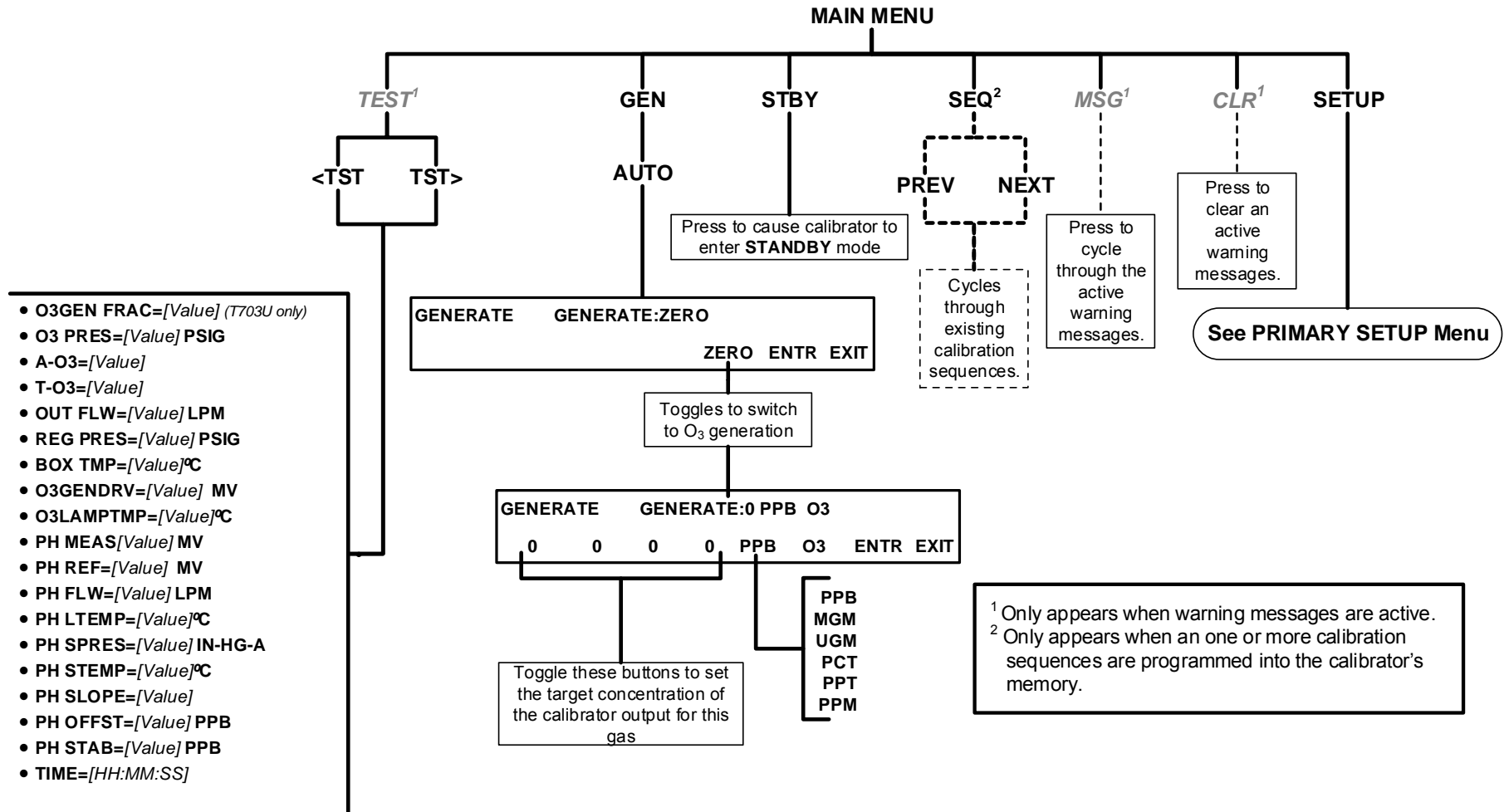

Figure A-1: Main Menu

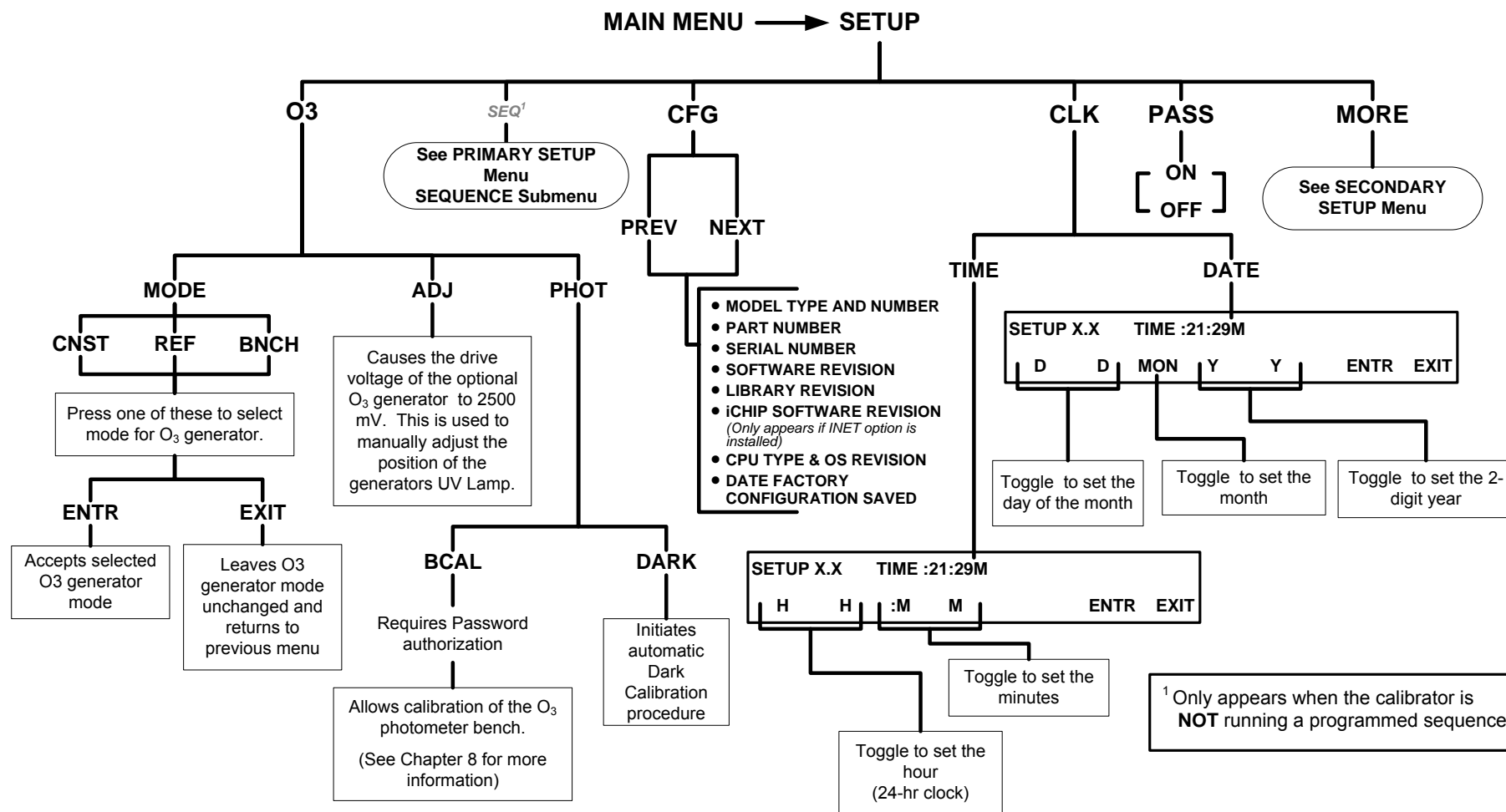

Figure A-2: PRIMARY SETUP MENU - Basics

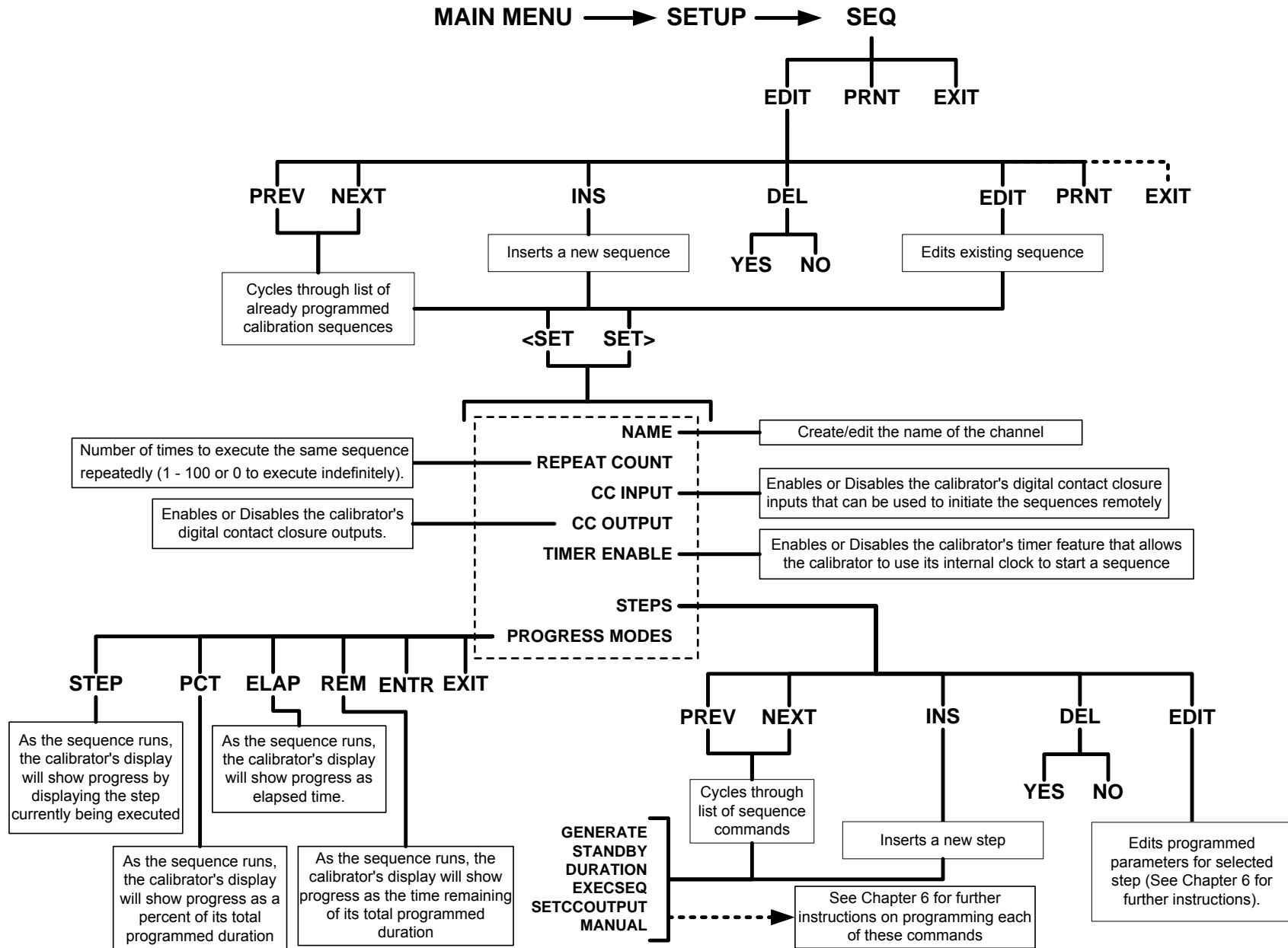
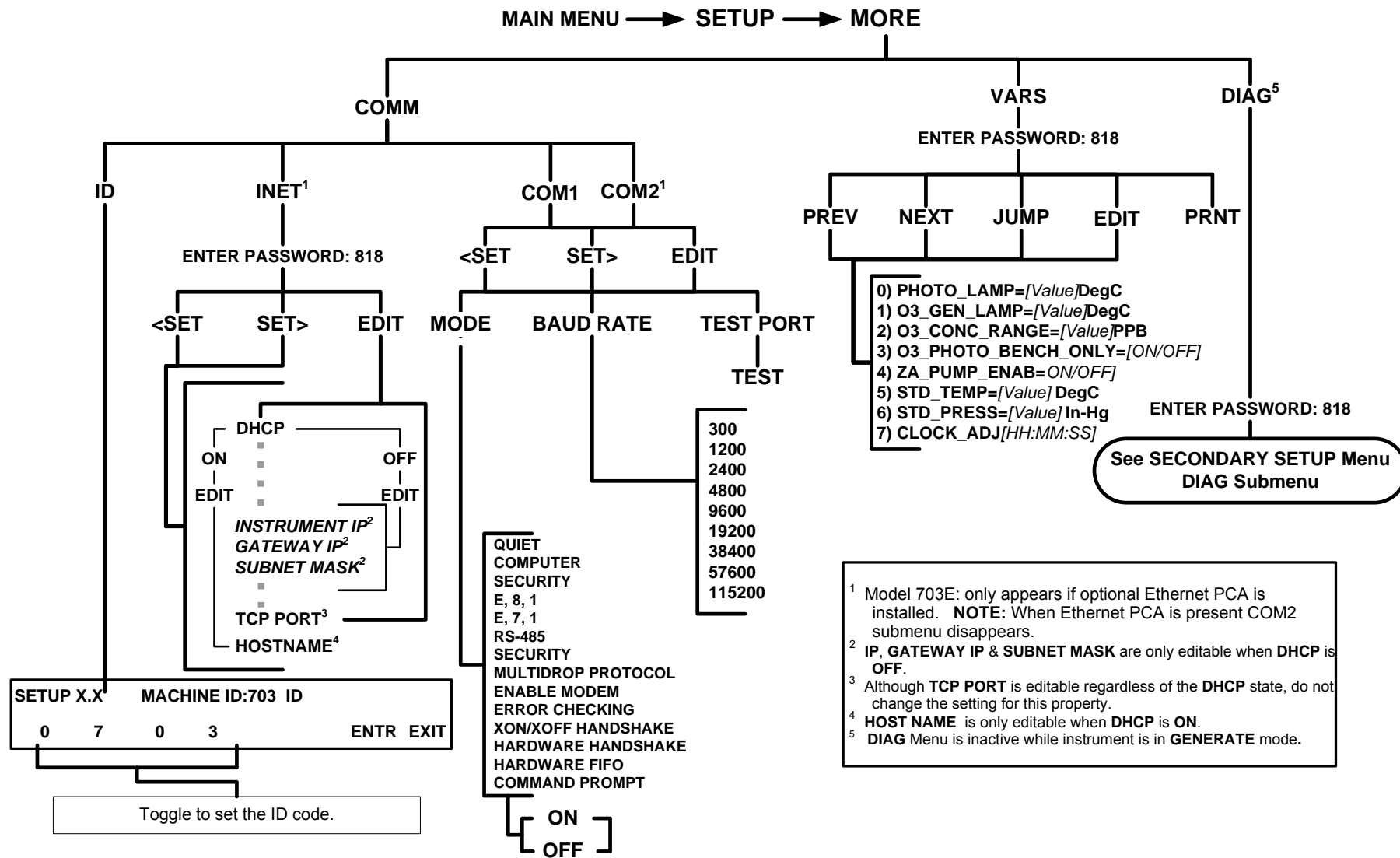

Figure A-3: PRIMARY SETUP Menu - SEQUENCE CONFIGURATION Submenu



¹ Model 703E: only appears if optional Ethernet PCA is installed. **NOTE:** When Ethernet PCA is present COM2 submenu disappears.
² IP, GATEWAY IP & SUBNET MASK are only editable when DHCP is OFF.
³ Although TCP PORT is editable regardless of the DHCP state, do not change the setting for this property.
⁴ HOST NAME is only editable when DHCP is ON.
⁵ DIAG Menu is inactive while instrument is in GENERATE mode.

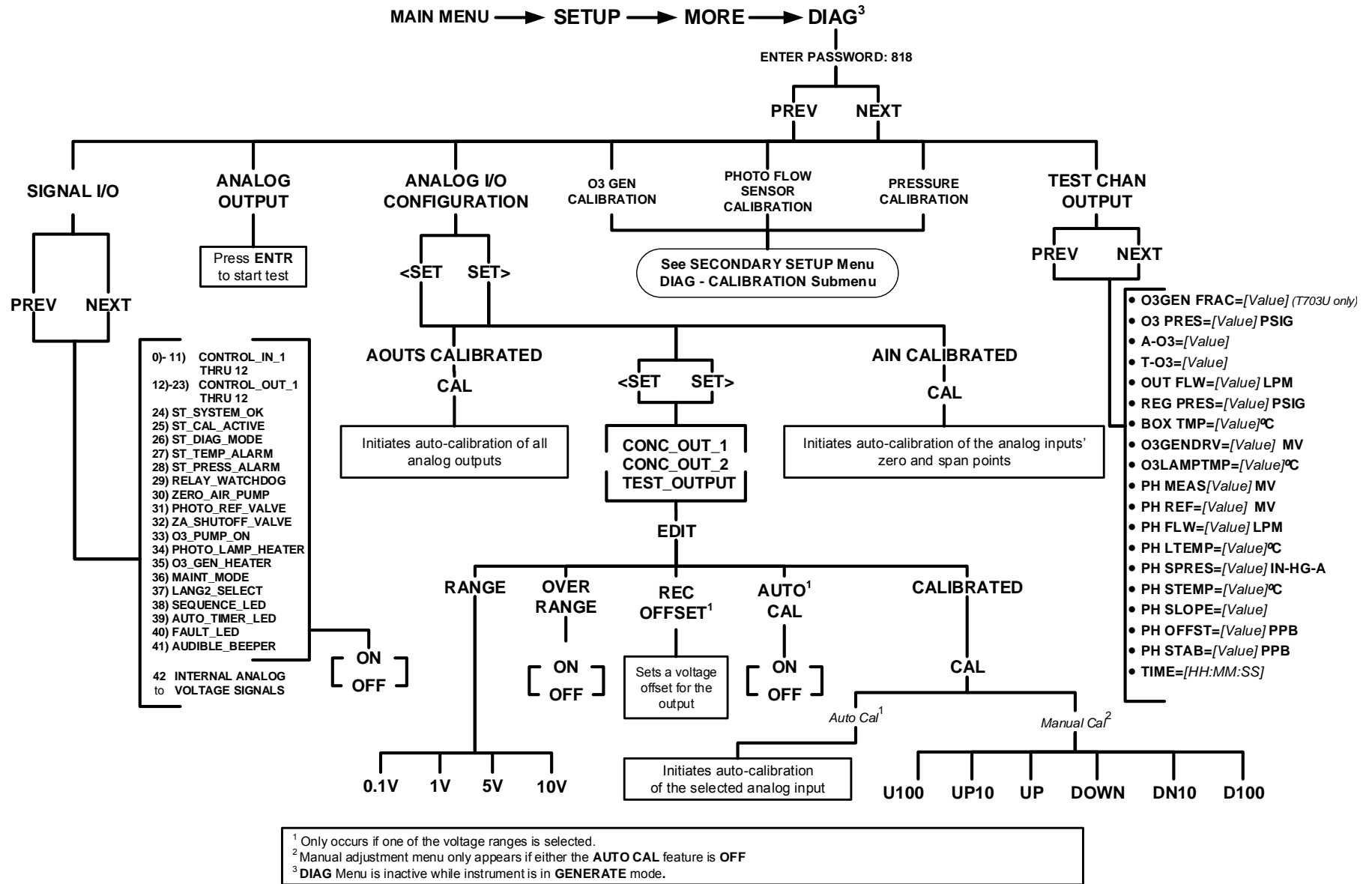

Figure A-5: SECONDARY SETUP Menu; DIAG Submenu – Basics

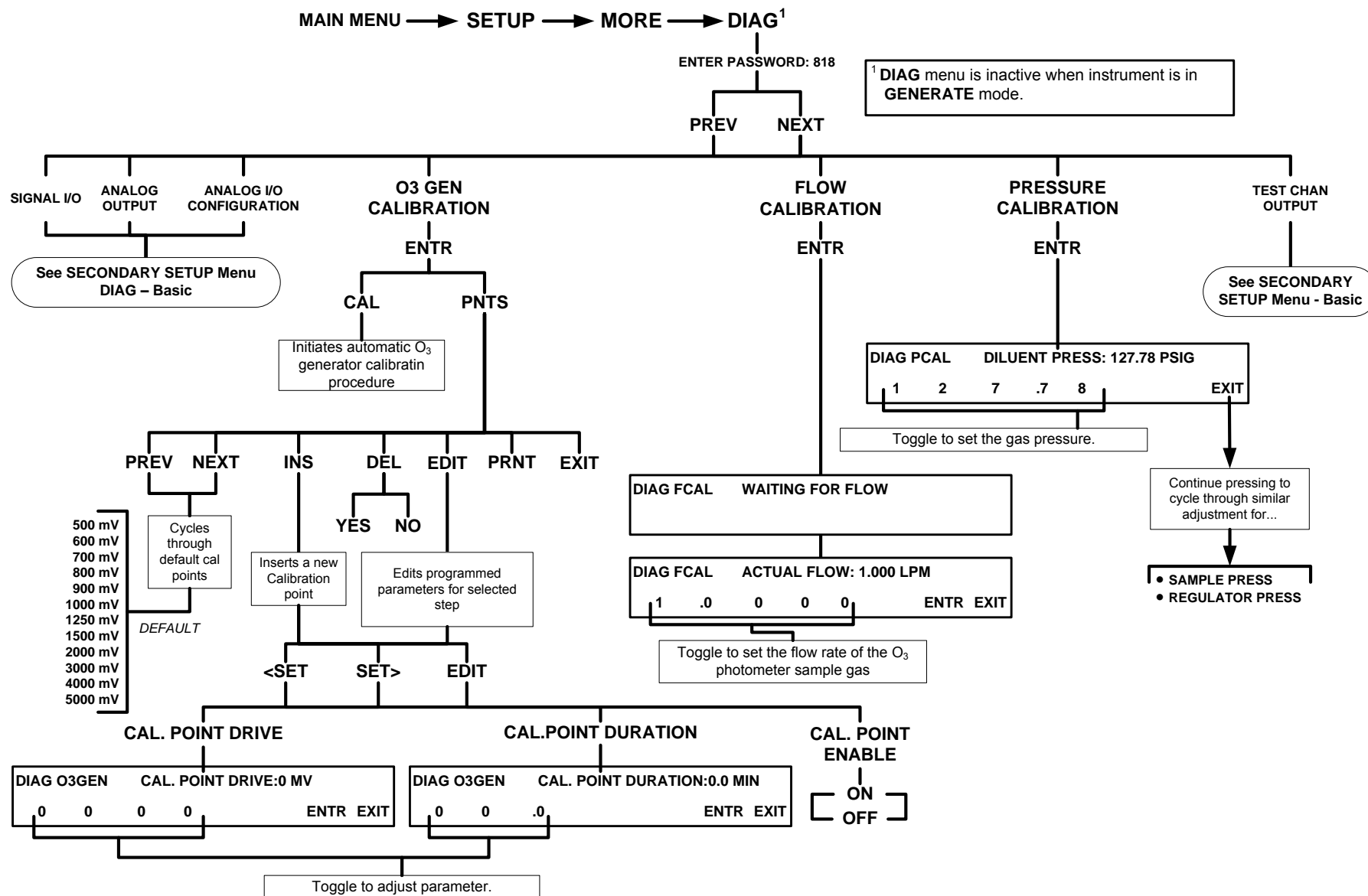

Figure A-6: SECONDARY SETUP Menu; DIAG Submenu – GAS CONFIGURATION

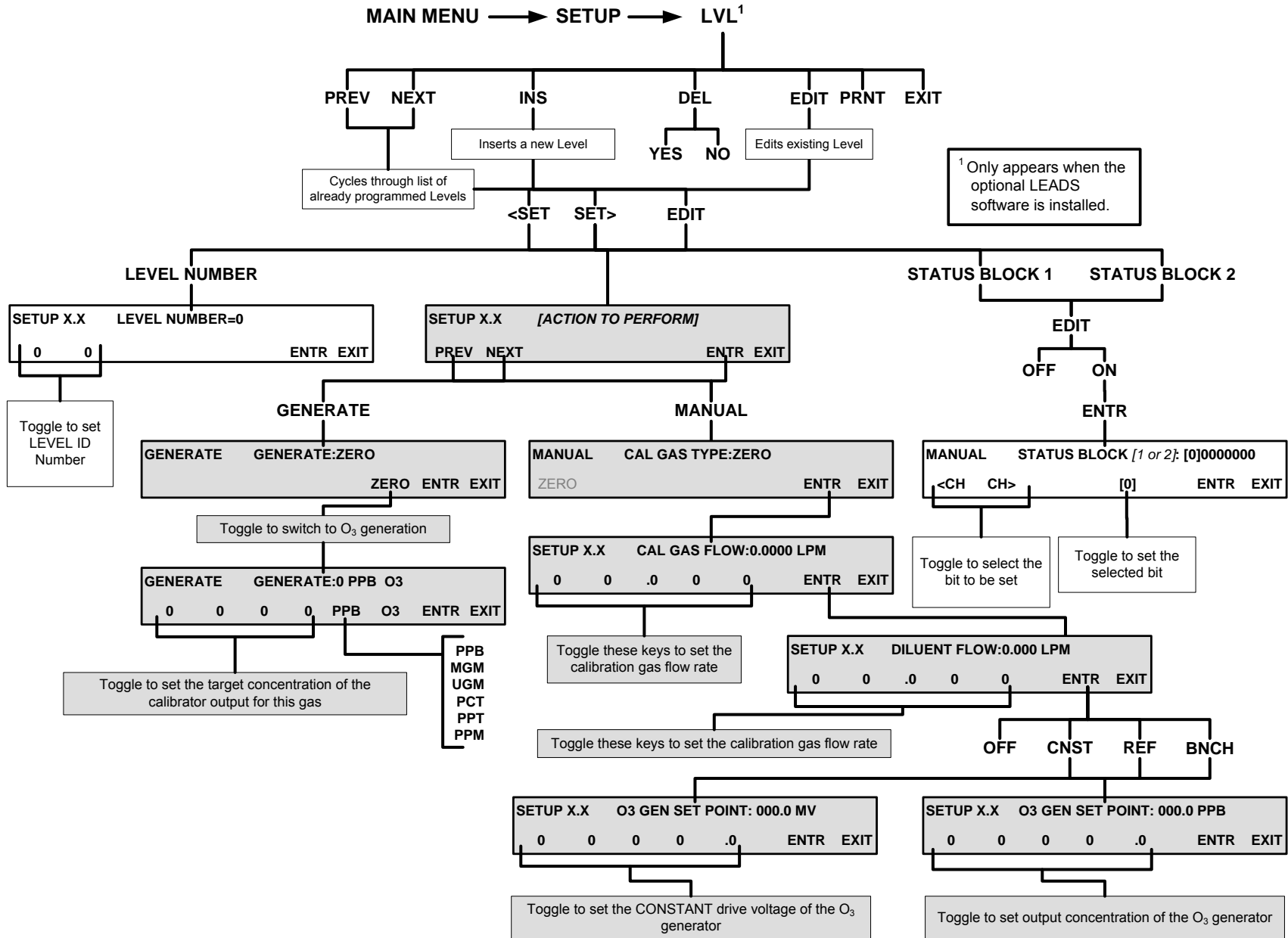

Figure A-7: PRIMARY SETUP Menu; LVL Submenu – programming LEADS LEVELS (optional)

This page intentionally left blank.

APPENDIX A-2: Serial I/O Setup Variables

Table A-1: Setup Variables

Setup Variable	Numeric Units	Default Value	Value Range	Description
PHOTO_LAMP	°C	58	0–100	Photometer lamp temperature set point and warning limits.
		Warnings: 56–61		
O3_GEN_LAMP	°C	48	0–100	O ₃ generator lamp temperature set point and warning limits.
		Warnings: 43–53		
O3_CONC_RANGE	PPB	500	0.1–20000	O ₃ concentration range for test channel analog output.
O3_PHOTO_BENCH_ONLY	—	OFF	OFF, ON	O ₃ bench control flag. ON turns on pump and switches measure/reference valve only in bench generation mode.
ZA_PUMP_ENAB	—	ON	OFF, ON	Zero air pump control. ON turns on zero air pump when generating ozone.
STD_TEMP	°C	25	0–100	Standard temperature for unit conversions.
STD_PRESS	"Hg	29.92	15–50	Standard pressure for unit conversions.
CLOCK_ADJ	Sec./Day	0	-60–60	Time-of-day clock speed adjustment.
SERVICE_CLEAR	—	OFF	OFF ON	ON resets the service interval timer.
TIME_SINCE_SVC	Hours	0	0–500000	Time since last service.
SVC_INTERVAL	Hours	0	0–100000	Sets the interval between service reminders.

APPENDIX A-3: Warnings and Test Functions

Table A-2: Warning Messages

NAME ¹	MESSAGE TEXT	DESCRIPTION
WSYSRES	SYSTEM RESET	Instrument was power-cycled or the CPU was reset.
WDATAINIT	DATA INITIALIZED	Data storage was erased.
WCONFIGINIT	CONFIG INITIALIZED	Configuration storage was reset to factory configuration or erased.
WPHOTOLTEMP	PHOTO LAMP TEMP WARNING	Photometer lamp temperature outside of warning limits.
WO3GENTEMP	O3 GEN LAMP TEMP WARNING	O ₃ generator lamp temperature outside of warning limits.
WPHOTOREF	PHOTO REFERENCE WARNING	Photometer reference reading less than 2500 mV or greater than 4999 mV.
WLAMPSTABIL	PHOTO LAMP STABILITY WARNING	Photometer lamp reference step changes occur more than 25% of the time.
WO3PUMP	O3 PUMP WARNING	O ₃ pump failed to turn on within timeout period.
WBOXTEMP	BOX TEMP WARNING	Chassis temperature outside of warning limits.
WREARBOARD	REAR BOARD NOT DET	Rear board was not detected during power up.
WRELAYBOARD	RELAY BOARD WARN	Firmware is unable to communicate with the relay board.
WLAMPDRIVER	LAMP DRIVER WARN	Firmware is unable to communicate with either the O ₃ generator or photometer lamp I ² C driver chip.
WFRONTPANEL	FRONT PANEL WARN	Firmware is unable to communicate with the front panel.
WANALOGCAL	ANALOG CAL WARNING	The A/D or at least one D/A channel has not been calibrated.
¹ The name is used to request a message via the RS-232 interface, as in "T BOXTEMP".		

Table A-3: Test Functions

TEST FUNCTION NAME ¹	MESSAGE TEXT	DESCRIPTION
ACTCONC	ACT=GENERATE 37 PPB O3	Actual concentration being generated, computed from real-time inputs.
TARGCONC	TARG=GENERATE 100 PPB O3	Target concentration to generate.
OUTPUTFLOW	OUTPUT FLOW=7.3 LPM	Output flow rate (computed from regulator pressure).
REGPRESS	REG PRESSURE=20.1 PSIG	Regulator pressure.
BOXTEMP	BOX TEMP=31.2 C	Internal chassis temperature.
O3GENDRIVE	O3 GEN DRIVE=800.0 MV	O ₃ generator lamp drive output.
O3GENTEMP	O3 LAMP TEMP=49.7 C	O ₃ generator lamp temperature.
PHOTOMEAS	PHOTO MEASURE=2998.8 MV	Photometer detector measure reading.
PHOTOREF	PHOTO REFERENCE=3000.0 MV	Photometer detector reference reading.
PHOTOFLOW	PHOTO FLOW=0.2978 LPM	Photometer sample flow rate.
PHOTOLTEMP	PHOTO LAMP TEMP=52.6 C	Photometer lamp temperature.
PHOTOSPRESS	PHOTO SPRESS=29.9 IN-HG-A	Photometer sample pressure.
PHOSTEMP	PHOTO STEMP=31.8 C	Photometer sample temperature.
PHOTOSLOPE	PHOTO SLOPE=1.000	Photometer slope computed during zero/span bench calibration.
PHOTOOFFSET	PHOTO OFFSET=0.0 PPB	Photometer offset computed during zero/span bench calibration.
PHOTOSTABIL ²	PHOTO STABIL=0.1 PPB	Photometer concentration stability (standard deviation of 25 bench concentration samples taken 10 seconds apart).
TESTCHAN	TEST=2753.9 MV	Value output to <i>TEST_OUTPUT</i> analog output.
CLOCKTIME	TIME=14:48:01	Current instrument time of day clock.
¹ The name is used to request a message via the RS-232 interface, as in "T BOXTEMP".		
² O ₃ photometer stability measurement option.		

APPENDIX A-4: Signal I/O Definitions

Table A-4: Signal I/O Definitions

MODELS T703, T703U, 703E I/O Signal List for Latest Revision		
Signal Name	Bit or Channel Number	Description
U11, J1004, control inputs, pins 1-6 = bits 0-5, read, default I/O address 321 hex		
CONTROL_IN_1 – CONTROL_IN_6	0–5	0 = input asserted 1 = de-asserted
	6–7	Always 1
U14, J1006, control inputs, pins 1-6 = bits 0-5, read, default I/O address 325 hex		
CONTROL_IN_7 – CONTROL_IN_12	0–5	0 = input asserted 1 = de-asserted
	6–7	Always 1
U17, J1008, control outputs, pins 1-8 = bits 0-7, write, default I/O address 321 hex		
CONTROL_OUT_1 – CONTROL_OUT_8	0–7	0 = output asserted 1 = de-asserted
U21, J1008, control outputs, pins 9-12 = bits 0-3, write, default I/O address 325 hex		
CONTROL_OUT_9 – CONTROL_OUT_12	0–3	0 = output asserted 1 = de-asserted
U7, J108, internal inputs, pins 9-16 = bits 0-7, read, default I/O address 322 hex		
	0–7	Spare
U8, J108, internal outputs, pins 1-8 = bits 0-7, write, default I/O address 322 hex		
	0–7	Spare
U24, J1017, A status outputs, pins 1-8 = bits 0-7, write, default I/O address 323 hex		
ST_SYSTEM_OK	0	0 = system OK 1 = any alarm condition or in diagnostics mode
	1	Spare
ST_CAL_ACTIVE	2	0 = executing sequence 1 = not executing sequence
ST_DIAG_MODE	3	0 = in diagnostic mode 1 = not in diagnostic mode
ST_TEMP_ALARM	4	0 = any temperature alarm 1 = all temperatures OK
ST_PRESS_ALARM	5	0 = any pressure alarm 1 = all pressures OK
	6-7	Spare
U27, J1018, B status outputs, pins 1-8 = bits 0-7, write, default I/O address 324 hex		
	0-7	Spare
Relay board digital output (PCF8575), write, default I²C address 44 hex		
RELAY_WATCHDOG	0	Alternate between 0 and 1 at least every 5 seconds to keep relay board active

MODELS T703, T703U, 703E I/O Signal List for Latest Revision		
Signal Name	Bit or Channel Number	Description
ZERO_AIR_PUMP	1	0 = pump on for zero air 1 = off
	2–5	Spare
PHOTO_REF_VALVE	6	0 = photometer valve in reference position 1 = measure position
ZA_SHUTOFF_VALVE	7	0 = open zero air shutoff valve 1 = close
O3_PUMP_ON	8	0 = pump on for photometer to measure O ₃ 1 = off
	9–13	Spare
PHOTO_LAMP_HEATER	14	0 = O ₃ photometer lamp heater on 1 = off
O3_GEN_HEATER	15	0 = O ₃ generator lamp heater on 1 = off
Front panel I²C keyboard, default I²C address 4E hex		
MAINT_MODE	5 (input)	0 = maintenance mode 1 = normal mode
LANG2_SELECT	6 (input)	0 = select second language 1 = select first language (English)
SEQUENCE_LED	8 (output)	0 = sequence LED on (executing sequence) 1 = off
AUTO_TIMER_LED	9 (output)	0 = automatic timer LED on (automatic sequence timer enabled) 1 = off
FAULT_LED	10 (output)	0 = fault LED on 1 = off
AUDIBLE_BEEPER	14 (output)	0 = beeper on (for diagnostic testing only) 1 = off
Rear board primary MUX analog inputs		
PHOTO_DET	0	Photometer detector reading
N/A	1	N/A
	2	Spare
PHOTO_SAMP_PRES	3	Photometer sample pressure
	4	Temperature MUX
REGULATOR_PRESS	5	Regulator pressure
PHOTO_FLOW	6	Photometer flow
	7–8	Spare
REF_4096_MV	9	4.096V reference from MAX6241
	10-11	Spare
OUTPUT_FLOW	12	Output flow
	13	Spare
	14	DAC loopback MUX
REF_GND	15	Ground reference

MODELS T703, T703U, 703E I/O Signal List for Latest Revision		
Signal Name	Bit or Channel Number	Description
Rear board temperature MUX analog inputs		
BOX_TEMP	0	Internal box temperature
PHOTO_SAMP_TEMP	1	Photometer sample temperature
PHOTO_LAMP_TEMP	2	Photometer lamp temperature
O3_GEN_TEMP	3	O ₃ generator lamp temperature
	4–7	Spare
Rear board DAC MUX analog inputs		
DAC_CHAN_1	0	DAC channel 0 loopback
DAC_CHAN_2	1	DAC channel 1 loopback
DAC_CHAN_3	2	DAC channel 2 loopback
DAC_CHAN_4	3	DAC channel 3 loopback
Rear board analog outputs		
CONC_OUT_1	0	Concentration output #1
CONC_OUT_2	1	Concentration output #2
	2	Spare
TEST_OUTPUT	3	Test measurement output
I²C analog output (AD5321), default I²C address 18 hex		
PHOTO_LAMP_DRIVE	0	O ₃ photometer lamp drive (0–5V)
I²C analog output (AD5321), default I²C address 1A hex		
O3_GEN_DRIVE	0	O ₃ generator lamp drive (0–5V)

APPENDIX A-5: Terminal Command Designators**Table A-5: Terminal Command Designators**

COMMAND	ADDITIONAL COMMAND SYNTAX	DESCRIPTION
? [ID]		Display help screen and commands list
LOGON [ID]	password	Establish connection to instrument
LOGOFF [ID]		Terminate connection to instrument
T [ID]	SET ALL name hexmask	Display test(s)
	LIST [ALL name hexmask] [NAMES HEX]	Print test(s) to screen
	name	Print single test
	CLEAR ALL name hexmask	Disable test(s)
W [ID]	SET ALL name hexmask	Display warning(s)
	LIST [ALL name hexmask] [NAMES HEX]	Print warning(s)
	name	Clear single warning
	CLEAR ALL name hexmask	Clear warning(s)
C [ID]	ZERO LOWSPAN SPAN [1 2]	Enter calibration mode
	ASEQ number	Execute automatic sequence
	COMPUTE ZERO SPAN	Compute new slope/offset
	EXIT	Exit calibration mode
	ABORT	Abort calibration sequence
D [ID]	LIST	Print all I/O signals
	name[=value]	Examine or set I/O signal
	LIST NAMES	Print names of all diagnostic tests
	ENTER name	Execute diagnostic test
	EXIT	Exit diagnostic test
	RESET [DATA] [CONFIG] [exitcode]	Reset instrument
V [ID]	LIST	Print setup variables
	name[=value [warn_low [warn_high]]]	Modify variable
	name="value"	Modify enumerated variable
	CONFIG	Print instrument configuration
	MAINT ON OFF	Enter/exit maintenance mode
	MODE	Print current instrument mode

The command syntax follows the command type, separated by a space character. Strings in [brackets] are optional designators. The following key assignments also apply.

Table A-6: Terminal Key Assignments

TERMINAL KEY ASSIGNMENTS	
ESC	Abort line
CR (ENTER)	Execute command
Ctrl-C	Switch to computer mode
COMPUTER MODE KEY ASSIGNMENTS	
LF (line feed)	Execute command
Ctrl-T	Switch to terminal mode

APPENDIX A-6: MODBUS Registers

MODBUS Register Address (dec., 0-based)	Description	Units
MODBUS Floating Point Input Registers (32-bit IEEE 754 format; read in high-word, low-word order; read-only)		
0	Output flow rate	LPM
2	Photometer measured ozone concentration	PPB
4	N/A	-
6	Ozone generator lamp drive	mV
8	Ozone generator lamp temperature	°C
10	Regulator pressure	PSIG
12	Internal box temperature	°C
14	Photometer detector measure reading	mV
16	Photometer detector reference reading	mV
18	Photometer sample flow rate	LPM
20	Photometer lamp temperature	°C
22	Photometer sample pressure	Inches Hg
24	Photometer sample temperature	°C
26	Photometer slope computed during zero/span bench calibration	—
28	Photometer offset computed during zero/span bench calibration	PPB
30	Ground reference	mV
32	Precision 4.096 mV reference	mV
MODBUS Discrete Input Registers (single-bit; read-only)		
0	System reset warning	
1	Box temperature warning	
2	Photometer lamp temperature warning	
3	O ₃ generator lamp temperature warning	
4	Photometer reference warning	
5	N/A	
6	O ₃ generator reference detector warning	
7	Rear board communication warning	
8	Relay board communication warning	
9	O ₃ generator or photometer lamp I ² C driver chip communication warning	
10	Front panel communication warning	
11	Analog calibration warning	
12	System is OK (same meaning as <i>SYSTEM_OK</i> I/O signal)	
13	O ₃ generator not yet stabilized	
14	Calibration is active	
15	Sequence is active	
16	Regulator pressure warning ¹	

MODBUS Register Address (dec., 0-based)	Description	Units
MODBUS Coil Registers (single-bit; read/write)		
00-99	Trigger execution of sequence whose name begins with "00" - "99". Turning a coil on executes a sequence. Turning a coil off does nothing. When reading coils, the value indicates which sequence is executing. If a coil is on, the sequence is executing; if off the sequence is not executing. Supports nested sequences, so multiple sequence coils may be on simultaneously.	
100	Turning coil on turns on purge. Turning coil off does nothing. When reading coil, the value indicates whether purge is active. If on, purge is active; if off, purge is not active. Purge may be invoked within a sequence, so purge coil may be on at the same time as a sequence coil.	
101	Turning coil on puts instrument in standby. Turning coil off does nothing. When reading coil, the value indicates whether instrument is in standby mode. If on, instrument is in standby; if off, instrument is not in standby.	
200-211	Connected to the control outputs (CONTROL_OUT_1– CONTROL_OUT_12). These coils may be turned both on and off. Reading the coils indicates the current state.	
¹ Regulator pressure monitoring option.		

This page intentionally left blank.

APPENDIX B - Spare Parts

Note Use of replacement parts other than those supplied by Teledyne Advanced Pollution Instrumentation (TAPI) may result in non-compliance with European standard EN 61010-1.

Note Due to the dynamic nature of part numbers, please refer to the TAPI Website at <http://www.teledyne-api.com> or call Customer Service at 800-324-5190 for more recent updates to part numbers.

This page intentionally left blank.

T703 Spare Parts List

(Reference: 07224 11/12/2010 2:01:02 PM)

PARTNUMBER	DESCRIPTION
000940100	CD, ORIFICE, .003 GREEN
006120100	ASSY,OZ.GEN LAMP (BIR) (OP5)
022710000	ABSORPTION TUBE, QUARTZ, (KB)
040010000	ASSY, FAN REAR PANEL
040030700	PCA, PRESS SENSORS (2X), PHOTO OPT
040300110	ASSY, CONFIG PLUG, 100-115V
040300210	ASSY, CONFIG PLUG, 220-240V
041200000	PCA, DET PREAMP w/OP20
041200200	PCA, DET PREAMP w/OP20
041440000	PCA, DC HTR/TEMP, BENCH
042010000	ASSY, SAMPLE THERMISTOR
045230100	PCA, RELAY CARD
046740000	ASSY, PUMP, 12VDC (OP63)
049290000	CLIP, THERMISTOR HOLDER
050700500	KIT, RELAY BD, O3 CAL
052400000	ASSY, BENCH UV LAMP, (BIR), CR *
052910100	ASSY, OPTICAL BENCH, OZONE
055220000	ASSY, VALVE W/CONN, VA 59
055730000	ASSY, REGULATOR, FILTERS, 20LPM
056420000	ASSY, FLOW CNTRL,5LPM, DILUTION
056430000	ASSY, FLOW CONTROL, PHOTO REF
057360000	ASSY, 3/8" VENT ADAPTER
057660000	ASSY, DFU FILTER
057670000	ASSY, CARBON SCRUBBER
058021400	PCA, MTHRBRD, CAL, GEN 5-I
058110000	ASSY, EXPENDABLES w/AKIT,*
058330000	ASSY, INT PUMP, 115V
058330100	ASSY, INT PUMP, 230V
064130000	ASSY, DC HEATER/THERM PCA, O3 GEN
066970000	PCA, INTRF. LCD TOUCH SCRN, F/P
067240000	CPU, PC-104, VSX-6154E, ICOP *
067300000	PCA, AUX-I/O BD, ETHERNET, ANALOG & USB
067300100	PCA, AUX-I/O BOARD, ETHERNET
067300200	PCA, AUX-I/O BOARD, ETHERNET & USB
067900000	LCD MODULE, W/TOUCHSCREEN
068810000	PCA, LVDS TRANSMITTER BOARD
069500000	PCA, SERIAL & VIDEO INTERFACE BOARD
072150000	ASSY. TOUCHSCREEN CONTROL MODULE
072230000	MANUAL, OPERATORS, T703
072250100	DOM, w/SOFTWARE, STD, T703 *
CN0000073	POWER ENTRY, 120/60 (KB)
FL0000001	FILTER, SS (KB)
FL0000003	FILTER, DFU (KB)
FL0000020	CARBON FILTER, DAU, 000 GRADE *(KB)
FM0000004	FLOWMETER (KB)
FM0000005	FLOW RESTRICTOR, 5000-1/4-10000CCM
FM0000006	FLOW RESTRICTOR, 5000-1/4-5000CCM
HW0000005	FOOT
HW0000020	SPRING

T703 Spare Parts List

(Reference: 07224 11/12/2010 2:01:02 PM)

PARTNUMBER	DESCRIPTION
HW0000380	HANDLE, CARRYING, 9.25", BLK *
HW0000453	SUPPORT, CIRCUIT BD, 3/16" ICOP
HW0000685	LATCH, MAGNETIC, FRONT PANEL
KIT000253	ASSY & TEST, SPARE PS37
KIT000254	ASSY & TEST, SPARE PS38
KIT000289	AKIT, UV LAMP P/S PCA, 041660100
OP0000014	QUARTZ DISC .75 DIA X 1/16", (KB)
OP0000031	WINDOW, QUARTZ, 1/2" DIA, .063" THICK (KB)
OR0000001	ORING, 2-006VT *(KB)
OR0000016	ORING, 2-120V
OR0000026	ORING, 2-110 S604-70
OR0000034	ORING, 2-011V FT10
OR0000039	ORING, 2-012V
OR0000048	ORING, 2-112S
OR0000077	ORING, 2-018V
OR0000089	ORING, 2-016V
RL0000015	RELAY, DPDT, (KB)
SW0000025	SWITCH, POWER, CIRC BREAK, VDE/CE *(KB)
SW0000059	PRESSURE SENSOR, 0-15 PSIA, ALL SEN
SW0000060	PRESSURE SENSOR, 0-100 PSIG, ALL SEN
VA0000014	REGULATOR
VA0000060	CHECK VALVE, B, 1/4" TUBE FITTINGS
WR0000008	POWER CORD, 10A(KB)

T703U Spare Parts List

(Ref: 077470000, 11/19/2012, 8:51a.m.)

PARTNUMBER	DESCRIPTION
000941600	CD, ORIFICE, .002
000941300	CD, ORIFICE, .006
064990100	ASSY, O3 GEN, 703U
006120100	ASSY,OZ.GEN LAMP (BIR) (OP5)
022710000	ABSORPTION TUBE, QUARTZ, (KB)
040010000	ASSY, FAN REAR PANEL (B/F)
040030700	PCA, PRESS SENSORS (2X), PHOTO OPT
040030600	PCA, PRESS SENSORS (1X), OZONE OPT
040300110	ASSY, CONFIG PLUG, 100-115V
040300210	ASSY, CONFIG PLUG, 220-240V
041200000	PCA, DET PREAMP w/OP20
041200200	PCA, DET PREAMP w/OP20
041440000	PCA, DC HTR/TEMP, BENCH
042010000	ASSY, SAMPLE THERMISTOR
045230100	PCA, RELAY CARD(KB)
046740000	ASSY, PUMP, 12VDC (PU63)
049290000	CLIP, THERMISTOR HOLDER
050700500	KIT, RELAY BD, O3 CAL, (KB)
052400000	ASSY, BENCH UV LAMP, (BIR), CR *
052910100	ASSY, OPTICAL BENCH, OZONE
059430000	ASSY, VALVE, VA59 w/o DIODE, 5" LEADS *
055730000	ASSY, REGULATOR, FILTERS, 20LPM, 703
056420000	ASSY, FLOW CNTRL,5LPM, DILUTION
056430000	ASSY, FLOW CONTROL, PHOTO REF
057360000	ASSY, 3/8" VENT ADAPTER
057660000	ASSY, DFU FILTER
057670000	ASSY, CARBON SCRUBBER
058021400	PCA, MTHRBRD, CAL, GEN 5-I (KB)
058110000	ASSY, EXPENDABLES w/AKIT,*
058330000	ASSY, INT PUMP, 115V
058330100	ASSY, INT PUMP, 230V
064130000	ASSY, DC HEATER/THERM PCA, O3 GEN
066970000	PCA, INTRF. LCD TOUCH SCRN, F/P
067240000	CPU, PC-104, VSX-6154E, ICOP *(KB)
067300000	PCA, AUX-I/O BD, ETHERNET, ANALOG & USB
067300100	PCA, AUX-I/O BOARD, ETHERNET
067300200	PCA, AUX-I/O BOARD, ETHERNET & USB
067900000	LCD MODULE, W/TOUCHSCREEN(KB)
068810000	PCA, LVDS TRANSMITTER BOARD
069500000	PCA, SERIAL & VIDEO INTERFACE BOARD
072150000	ASSY. TOUCHSCREEN CONTROL MODULE
072230000	MANUAL, OPERATORS, T703
072250100	DOM, w/SOFTWARE, STD, T703 *
FL0000001	FILTER, SS (KB)
FL0000003	FILTER, DFU (KB)
FL0000020	CARBON FILTER, DAU, 000 GRADE *(KB)
FM0000004	FLOWMETER (KB)

T703U Spare Parts List

(Ref: 077470000, 11/19/2012, 8:51a.m.)

PARTNUMBER	DESCRIPTION
FM0000005	FLOW RESTRICTOR, 5000-1/4-10000CCM NONE
FM0000006	FLOW RESTRICTOR, 5000-1/4-5000CCM BLACK
HW0000020	SPRING
HW0000380	HANDLE, CARRYING, 9.25", BLK *
HW0000453	SUPPORT, CIRCUIT BD, 3/16" ICOP
HW0000685	LATCH, MAGNETIC, FRONT PANEL (KB)
KIT000253	ASSY & TEST, SPARE PS37
KIT000254	ASSY & TEST, SPARE PS38
KIT000289	AKIT, UV LAMP P/S PCA, 041660100
OP0000014	QUARTZ DISC .75 DIA X 1/16", (KB)
OP0000031	WINDOW, QUARTZ, 1/2" DIA, .063" THICK (KB)
OR0000001	ORING, 2-006VT *(KB)
RL0000015	RELAY, DPDT, (KB)
SW0000025	SWITCH, POWER, CIRC BREAK, VDE/CE *(KB)
SW0000059	PRESSURE SENSOR, 0-15 PSIA, ALL SEN
SW0000060	PRESSURE SENSOR, 0-100 PSIG, ALL SEN
FM0000007	REGULATOR, PRESSURE, 0-30PSI(KB)
060720100	ASSY, REGULATOR W/FITTING
VA0000060	CHECK VALVE, B, 1/4" TUBE FITTINGS
WR0000008	POWER CORD, 10A(KB)
FT0000337	TEE, BRASS, 1/4" BARB
FT0000429	ORIFICE, BARB, SS, 0.012" (KB)
FT0000431	TEE, TFE, 1/4"-1/4"-1/8"
VA0000060	CHECK VALVE, B, 1/4" TUBE FITTINGS
VA0000024	VALVE, MANIFOLD, 3-WAY CLIPPARD

Appendix C
Warranty/Repair Questionnaire
T703, T703U, 703E
 (05747E DCN7107)



CUSTOMER: _____ PHONE: _____

CONTACT NAME: _____ FAX NO. _____

SITE ADDRESS: _____

MODEL TYPE: _____ SERIAL NO.: _____ FIRMWARE REVISION: _____

Are there any failure messages? _____

(Continue on back if necessary)

PLEASE COMPLETE THE FOLLOWING TABLE:

PARAMETER		RECORDED VALUE	ACCEPTABLE VALUE
Name in E-Series software versions prior to v.C.1	Name in T-Series and in E-Series w/software v. C.1 and higher.		
ACT	ACT	PPB	1% OF TARG
TARG	TAR	PPB	50 – 1000 PPB
OUTPUT FLOW	OUT FLW	LPM	2 – 5 LPM
REG PRESSURE	REG PRES	PSIG	15 ± 2 PSIG @ 5 LPM
(n/a)	O3 PRES^{1,2} (703U only)	PSIG	8 ± 1 PSIG @ 5 LPM
BOX TEMP	BOX TMP	°C	20 – 35 °C
O3 GEN REF²	O3GEN REF²	mV	0 – 5000 mV
O3 GEN DRIVE²	O3GENDRV²	mV	0 – 5000mV
O3 LAMP TEMP²	O3LAMPTMP²	°C	48 ± 1 °C
PHOTO MEASURE²	PH MEAS²	mV	2500 – 4700 mV
PHOTO REFERENCE²	PH REF²	mV	2500 – 4700 mV
PHOTO FLOW²	PH FLW²	LPM	0.720 – 0.880 LPM
PHOTO LAMP TEMP²	PH LTEMP²	°C	58 ± 1 °C
PHOTO SPRESS²	PH SPRES²	IN-HG-A	-1" AMBIENT IN-HG-A
PHOTO STEMP²	PH STEMP²	°C	25 – 48°C
PHOTO SLOPE²	PH SLOPE²		1 ± 0.15
PHOTO OFFSET²	PH OFFST²	PPB	0 ± 10 PPB
(n/a)	PH STAB²	PPB	<1 ppb on Zero Air

NOTE: Depending on options installed, not all test parameters shown will be available in your calibrator.
¹ Ozone Regulator Pressure
² If applicable option installed.

What is measured photometer flow rate _____ cc³/min

Teledyne API Technical Support
 Email: sda_techsupport@teledyne.com
 PHONE: (858) 657-9800 TOLL FREE: (800) 324-5190 FAX: (858) 657-9816

APPENDIX D – Wire List and Electronic Schematics

This page intentionally left blank.

T703 Interconnect List

(Reference: 073600100A DCN5882)

Cable Part #	Signal	CONNECTION FROM				CONNECTION TO			
		Assembly	PN	J/P	Pin	Assembly	PN	J/P	Pin
0364901	CBL, AC Power, E-series								
	AC Line	Power Entry	CN0000073		L	Power Switch	SW0000025		L
	AC Neutral	Power Entry	CN0000073		N	Power Switch	SW0000025		N
	Power Grnd	Power Entry	CN0000073			Shield	SW0000025		
	Power Grnd	Power Entry	CN0000073			Chassis	052590000		
	AC Line Switched	Power Switch	SW0000025		L	PS2 (+12)	068020000	J1	1
	AC Neutral Switched	Power Switch	SW0000025		N	PS2 (+12)	068020000	J1	3
	Power Grnd	Power Entry	CN0000073			PS2 (+12)	068020000	J1	2
	AC Line Switched	Power Switch	SW0000025		L	PS1 (+5, ±15)	068010000	J1	1
	AC Neutral Switched	Power Switch	SW0000025		N	PS1 (+5, ±15)	068010000	J1	3
	Power Grnd	Power Entry	CN0000073			PS1 (+5, ±15)	068010000	J1	2
	AC Line Switched	Power Switch	SW0000025		L	Relay Board	045230100	J1	1
	AC Neutral Switched	Power Switch	SW0000025		N	Relay Board	045230100	J1	3
	Power Grnd	Power Entry	CN0000073			Relay Board	045230100	J1	2
03829	CBL, DC Power to Motherboard								
	DGND	Relay Board	045230100	J7	1	Motherboard	058021400	J15	1
	+5V	Relay Board	045230100	J7	2	Motherboard	058021400	J15	2
	AGND	Relay Board	045230100	J7	3	Motherboard	058021400	J15	3
	+15V	Relay Board	045230100	J7	4	Motherboard	058021400	J15	4
	AGND	Relay Board	045230100	J7	5	Motherboard	058021400	J15	5
	-15V	Relay Board	045230100	J7	6	Motherboard	058021400	J15	6
	+12V RET	Relay Board	045230100	J7	7	Motherboard	058021400	J15	7
	+12V	Relay Board	045230100	J7	8	Motherboard	058021400	J15	8
	Chassis Gnd	Relay Board	045230100	J7	10	Motherboard	058021400	J15	9
04105	CBL, Keyboard to Motherboard								
	Kbd Interupt	LCD Interface PCA	066970000	J1	7	Motherboard	058021400	J106	1
	DGND	LCD Interface PCA	066970000	J1	2	Motherboard	058021400	J106	8
	SDA	LCD Interface PCA	066970000	J1	5	Motherboard	058021400	J106	2
	SCL	LCD Interface PCA	066970000	J1	6	Motherboard	058021400	J106	6
	Shld	LCD Interface PCA	066970000	J1	10	Motherboard	058021400	J106	5
041760000	CBL, DC Power, EOS								
	DGND	Relay Board	045230100	J8	1	PS1 (+5, ±15)	068010000	J2	3
	+5V	Relay Board	045230100	J8	2	PS1 (+5, ±15)	068010000	J2	1
	+15V	Relay Board	045230100	J8	4	PS1 (+5, ±15)	068010000	J2	6
	AGND	Relay Board	045230100	J8	5	PS1 (+5, ±15)	068010000	J2	4
	-15V	Relay Board	045230100	J8	6	PS1 (+5, ±15)	068010000	J2	5
	+12V RET	Relay Board	045230100	J8	7	PS2 (+12)	068020000	J2	3
	+12V	Relay Board	045230100	J8	8	PS2 (+12)	068020000	J2	1
042790100	CBL, Heater/Thermistor								
	+12V RET	Relay Board	045230100	J19	1	Lamp HTR/Thrm	041440000		1
	+12V	Relay Board	045230100	J19	2	Lamp HTR/Thrm	041440000		2
	+5VANA	Motherboard	058021400	J27	6	Lamp HTR/Thrm	041440000		3
	THERMISTOR 3	Motherboard	058021400	J27	13	Lamp HTR/Thrm	041440000		4
	+5VANA	Motherboard	058021400	J27	7	Sample Therm	042010000		1
	THERMISTOR 2	Motherboard	058021400	J27	14	Sample Therm	042010000		2
	THERMISTOR 4	Motherboard	058021400	J27	12	O3 Gen HTR/Therm	041440100		6
	+5VANA	Motherboard	058021400	J27	5	O3 Gen HTR/Therm	041440100		5
	+12V RET	Relay Board	045230100	J14	2	O3 Gen HTR/Therm	041440100		2
	+12V	Relay Board	045230100	J14	1	O3 Gen HTR/Therm	041440100		1

T703 Interconnect List

(Reference: 073600100A DCN5882)

Cable Part #	Signal	CONNECTION FROM				CONNECTION TO			
		Assembly	PN	J/P	Pin	Assembly	PN	J/P	Pin
042800100 CBL, Power & Signal Distribution									
	CH1	Motherboard	058021400	J109	6	UV Det - Bench	041200000	P3	1
	AGND	Motherboard	058021400	J109	12	UV Det - Bench	041200000	P3	4
	+15V	Relay Board	045230100	J5	4	Bench Lamp Supply	041200000	P3	2
	-15V	Relay Board	045230100	J5	6	Bench Lamp Supply	041200000	P3	3
	+12V RET	Relay Board	045230100	J5	7	Fan	040010000	P1	1
	+12V	Relay Board	045230100	J5	8	Fan	040010000	P1	2
	CH6	Motherboard	058021400	J109	2	Photo Press/Flo	040030700	P1	4
	CH4	Motherboard	058021400	J109	3	Photo Press/Flo	040030700	P1	2
	CH7	Motherboard	058021400	J109	1	Photo Press/Flo	040030700	P1	5
	AGND	Relay Board	045230100	J9	3	Photo Press/Flo	040030700	P1	3
	+15V	Relay Board	045230100	J9	4	Photo Press/Flo	040030700	P1	6
	DGND	Relay Board	045230100	J9	1	LCD Interface PCA	066970000	J14	8
	VCC	Relay Board	045230100	J9	2	LCD Interface PCA	066970000	J14	1
	DGND	Relay Board	045230100	J12	1	LCD Interface PCA	066970000	J14	2
	VCC	Relay Board	045230100	J12	2	LCD Interface PCA	066970000	J14	3
	+15V	Relay Board	045230100	J12	4	IZ Det	041200000	P3	2
	-15V	Relay Board	045230100	J12	6	IZ Det	041200000	P3	3
	CH2	Motherboard	058021400	J109	5	IZ Det	041200000	P3	1
	AGND	Motherboard	058021400	J109	11	IZ Det	041200000	P3	4
04671 CBL, Motherboard to Transmitter Board (Multidrop Option)									
	GND	Motherboard	058021400	P12	2	Xmitter bd w/Multidrop	069500000	J4	2
	RX0	Motherboard	058021400	P12	14	Xmitter bd w/Multidrop	069500000	J4	14
	RTS0	Motherboard	058021400	P12	13	Xmitter bd w/Multidrop	069500000	J4	13
	TX0	Motherboard	058021400	P12	12	Xmitter bd w/Multidrop	069500000	J4	12
	CTS0	Motherboard	058021400	P12	11	Xmitter bd w/Multidrop	069500000	J4	11
	RS-GND0	Motherboard	058021400	P12	10	Xmitter bd w/Multidrop	069500000	J4	10
	RTS1	Motherboard	058021400	P12	8	Xmitter bd w/Multidrop	069500000	J4	8
	CTS1/485-	Motherboard	058021400	P12	6	Xmitter bd w/Multidrop	069500000	J4	6
	RX1	Motherboard	058021400	P12	9	Xmitter bd w/Multidrop	069500000	J4	9
	TX1/485+	Motherboard	058021400	P12	7	Xmitter bd w/Multidrop	069500000	J4	7
	RS-GND1	Motherboard	058021400	P12	5	Xmitter bd w/Multidrop	069500000	J4	5
	RX1	Motherboard	058021400	P12	9	Xmitter bd w/Multidrop	069500000	J4	9
	TX1/485+	Motherboard	058021400	P12	7	Xmitter bd w/Multidrop	069500000	J4	7
	RS-GND1	Motherboard	058021400	P12	5	Xmitter bd w/Multidrop	069500000	J4	5
054840000 CBL, Valve Driver & Pump Power									
	+12V	Relay Board	045230100	J4	1	Photo Ref Valve	055220000		1
	+12V RET	Relay Board	045230100	J4	2	Photo Ref Valve	055220000		2
	+12V	Relay Board	045230100	J4	3	O3 Valve	055220000		1
	+12V RET	Relay Board	045230100	J4	4	O3 Valve	055220000		2
	+12V	Relay Board	045230100	J4	5	Pump	047020000		1
	+12V RET	Relay Board	045230100	J4	6	Pump	047020000		2
056310100 CBL, I2C Signal									
	+15V	IZS Lamp Supply	041660100	P1	1	Relay Board	045230100	J5	4
	AGND	IZS Lamp Supply	041660100	P1	2	Relay Board	045230100	J5	3
	SCL	IZS Lamp Supply	041660100	P1	3	Relay Board	045230100	J3	1
	SDA	IZS Lamp Supply	041660100	P1	4	Relay Board	045230100	J3	2
	Shield	Motherboard	058021400	J107	6	Relay Board	045230100	J3	5
	SCL	IZS Lamp Supply	041660100	P1	3	Bench Lamp Supply	041660500	P1	3
	SDA	IZS Lamp Supply	041660100	P1	4	Bench Lamp Supply	041660500	P1	4
	SCL	Motherboard	058021400	J107	3	Bench Lamp Supply	041660500	P1	3
	SDA	Motherboard	058021400	J107	5	Bench Lamp Supply	041660500	P1	4
	+15V	Relay Board	045230100	J10	4	Bench Lamp Supply	041660500	P1	1
	AGND	Relay Board	045230100	J10	3	Bench Lamp Supply	041660500	P1	2
05673 CBL, Pump Adapter									
	115VAC	Relay Board	045230100	J2	1	Pump	037070000		1
	230VAC	Relay Board	045230100	J2	5	Pump	037070000		2
	Neutral	Relay Board	045230100	J2	2	Pump	037070000		3
	Jumper	Relay Board	045230100	J2	3	Relay Board	045230100	J2	4
06737 CBL, I2C to AUX I/O (Analog In Option)									
	ATX-	Motherboard	058021400	J106	1	Aux I/O PCA	067300000	J2	1
	ATX+	Motherboard	058021400	J106	2	Aux I/O PCA	067300000	J2	2
	LED0	Motherboard	058021400	J106	3	Aux I/O PCA	067300000	J2	3
	ARX+	Motherboard	058021400	J106	4	Aux I/O PCA	067300000	J2	4
	ARX-	Motherboard	058021400	J106	5	Aux I/O PCA	067300000	J2	5
	LED0+	Motherboard	058021400	J106	6	Aux I/O PCA	067300000	J2	6
	LED1+	Motherboard	058021400	J106	8	Aux I/O PCA	067300000	J2	8

T703 Interconnect List

(Reference: 073600100A DCN5882)

Cable Part #	Signal	CONNECTION FROM				CONNECTION TO			
		Assembly	PN	J/P	Pin	Assembly	PN	J/P	Pin
06738	CBL, CPU COM to AUX I/O (USB Option)								
	RXD	CPU PCA	067240000	COM1	1	Aux I/O PCA	0673000 or -02	J3	1
	DCD	CPU PCA	067240000	COM1	2	Aux I/O PCA	0673000 or -02	J3	2
	DTR	CPU PCA	067240000	COM1	3	Aux I/O PCA	0673000 or -02	J3	3
	TXD	CPU PCA	067240000	COM1	4	Aux I/O PCA	0673000 or -02	J3	4
	DSR	CPU PCA	067240000	COM1	5	Aux I/O PCA	0673000 or -02	J3	5
	GND	CPU PCA	067240000	COM1	6	Aux I/O PCA	0673000 or -02	J3	6
	CTS	CPU PCA	067240000	COM1	7	Aux I/O PCA	0673000 or -02	J3	7
	RTS	CPU PCA	067240000	COM1	8	Aux I/O PCA	0673000 or -02	J3	8
	RI	CPU PCA	067240000	COM1	10	Aux I/O PCA	0673000 or -02	J3	10
06738	CBL, CPU COM to AUX I/O (Multidrop Option)								
	RXD	CPU PCA	067240000	COM1	1	Xmitter bd w/Multidrop	069500000	J3	1
	DCD	CPU PCA	067240000	COM1	2	Xmitter bd w/Multidrop	069500000	J3	2
	DTR	CPU PCA	067240000	COM1	3	Xmitter bd w/Multidrop	069500000	J3	3
	TXD	CPU PCA	067240000	COM1	4	Xmitter bd w/Multidrop	069500000	J3	4
	DSR	CPU PCA	067240000	COM1	5	Xmitter bd w/Multidrop	069500000	J3	5
	GND	CPU PCA	067240000	COM1	6	Xmitter bd w/Multidrop	069500000	J3	6
	CTS	CPU PCA	067240000	COM1	7	Xmitter bd w/Multidrop	069500000	J3	7
	RTS	CPU PCA	067240000	COM1	8	Xmitter bd w/Multidrop	069500000	J3	8
	RI	CPU PCA	067240000	COM1	10	Xmitter bd w/Multidrop	069500000	J3	10
06739	CBL, CPU Ethernet to AUX I/O								
	ATX-	CPU PCA	067240000	LAN	1	Aux I/O PCA	067300100	J2	1
	ATX+	CPU PCA	067240000	LAN	2	Aux I/O PCA	067300100	J2	2
	LED0	CPU PCA	067240000	LAN	3	Aux I/O PCA	067300100	J2	3
	ARX+	CPU PCA	067240000	LAN	4	Aux I/O PCA	067300100	J2	4
	ARX-	CPU PCA	067240000	LAN	5	Aux I/O PCA	067300100	J2	5
	LED0+	CPU PCA	067240000	LAN	6	Aux I/O PCA	067300100	J2	6
	LED1	CPU PCA	067240000	LAN	7	Aux I/O PCA	067300100	J2	7
	LED1+	CPU PCA	067240000	LAN	8	Aux I/O PCA	067300100	J2	8
06741	CBL, CPU USB to Front Panel								
	GND	CPU PCA	067240000	USB	8	LCD Interface PCA	066970000	JP9	
	LUSB3+	CPU PCA	067240000	USB	6	LCD Interface PCA	066970000	JP9	
	LUSB3-	CPU PCA	067240000	USB	4	LCD Interface PCA	066970000	JP9	
	VCC	CPU PCA	067240000	USB	2	LCD Interface PCA	066970000	JP9	
06746	CBL, MB TO 06154 CPU								
	GND	Motherboard	058021400	P12	2	Shield			
	RX0	Motherboard	058021400	P12	14	CPU PCA	067240000	COM1	1
	RTS0	Motherboard	058021400	P12	13	CPU PCA	067240000	COM1	8
	TX0	Motherboard	058021400	P12	12	CPU PCA	067240000	COM1	4
	CTS0	Motherboard	058021400	P12	11	CPU PCA	067240000	COM1	7
	RS-GND0	Motherboard	058021400	P12	10	CPU PCA	067240000	COM1	6
	RTS1	Motherboard	058021400	P12	8	CPU PCA	067240000	COM2	8
	CTS1/485-	Motherboard	058021400	P12	6	CPU PCA	067240000	COM2	7
	RX1	Motherboard	058021400	P12	9	CPU PCA	067240000	COM2	1
	TX1/485+	Motherboard	058021400	P12	7	CPU PCA	067240000	COM2	4
	RS-GND1	Motherboard	058021400	P12	5	CPU PCA	067240000	COM2	6
	RX1	Motherboard	058021400	P12	9	CPU PCA	067240000	485	1
	TX1/485+	Motherboard	058021400	P12	7	CPU PCA	067240000	485	2
	RS-GND1	Motherboard	058021400	P12	5	CPU PCA	067240000	485	3
WR256	CBL, Transmitter to Interface								
		LCD Interface PCA	066970000	J15		Transmitter PCA	068810000	J1	

This page intentionally left blank.

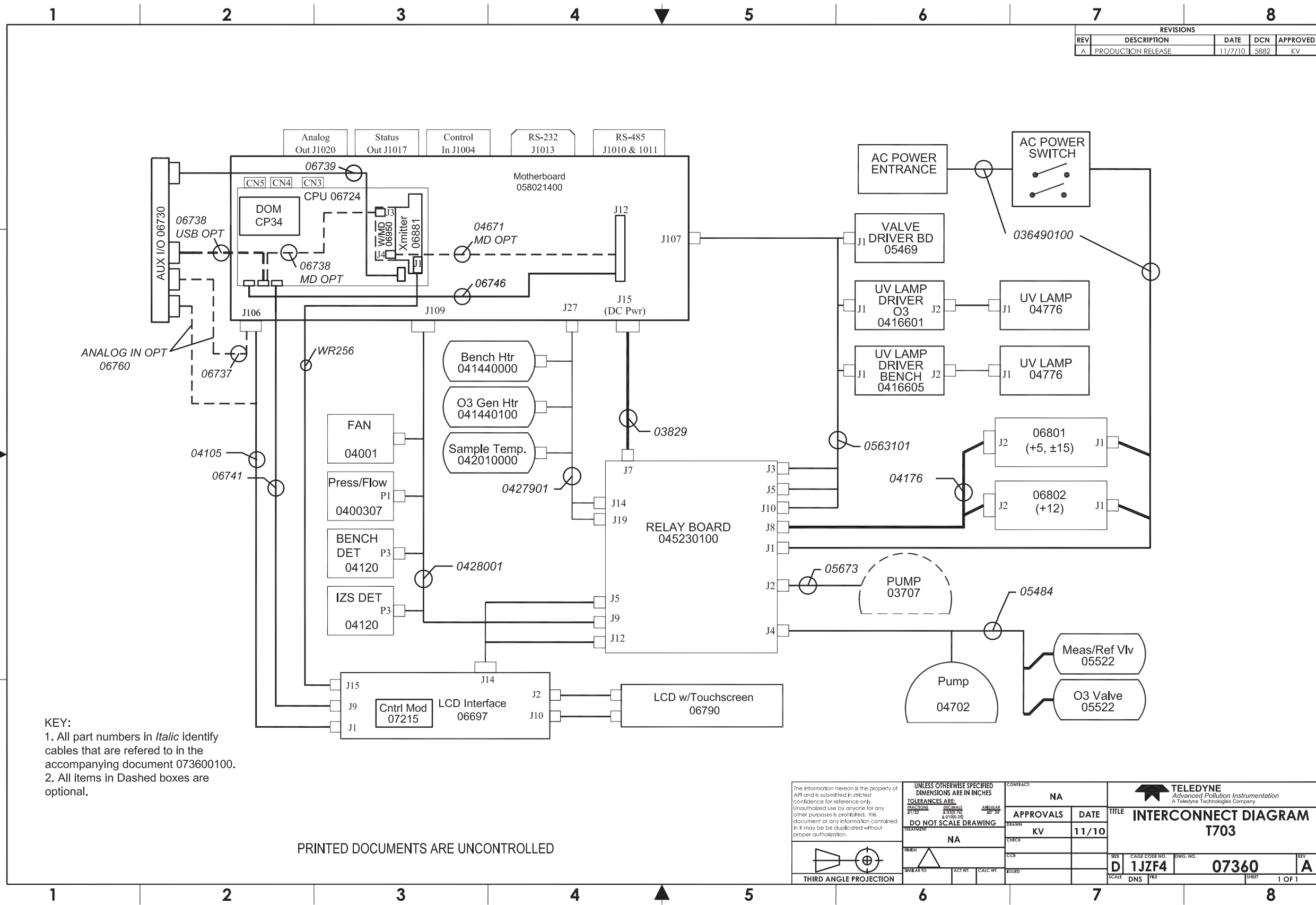

REVISIONS				
REV	DESCRIPTION	DATE	DCN	APPROVED
A	PRODUCTION RELEASE	11/7/10	5882	KV

KEY:
 1. All part numbers in *Italic* identify cables that are referred to in the accompanying document 073600100.
 2. All items in Dashed boxes are optional.

PRINTED DOCUMENTS ARE UNCONTROLLED

<small>The information herein is the property of API and is submitted in strictest confidence for reference only. Unauthorised use by anyone for any other purposes is prohibited. This document or any information contained in it may be duplicated without proper authorization.</small>	<small>UNLESS OTHERWISE SPECIFIED DIMENSIONS ARE IN INCHES</small>		<small>CONTRACT:</small> NA		 <small>Advanced Pollution Instrumentation A Teledyne Technologies Company</small>	
	<small>TOLERANCES ARE:</small> <small>FRACTIONS DECIMALS ANGULAR</small> <small>±0.005 ±0.010 ±0.015</small>		<small>APPROVALS</small> KV	<small>DATE</small> 11/10		<small>TITLE</small> INTERCONNECT DIAGRAM T703
	<small>DO NOT SCALE DRAWING</small>		<small>DRAWN</small> KV	<small>CHECK</small> 		<small>SCALE</small> D 1JZF4
	<small>TREATMENT</small> NA		<small>ISSUED</small> 	<small>CAGE CODE NO.</small> 07360		<small>DWG. NO.</small> 07360
<small>THIRD ANGLE PROJECTION</small>		<small>SCALE</small> DNS	<small>FILE</small> 	<small>SHEET</small> 1 OF 1	<small>REV</small> A	

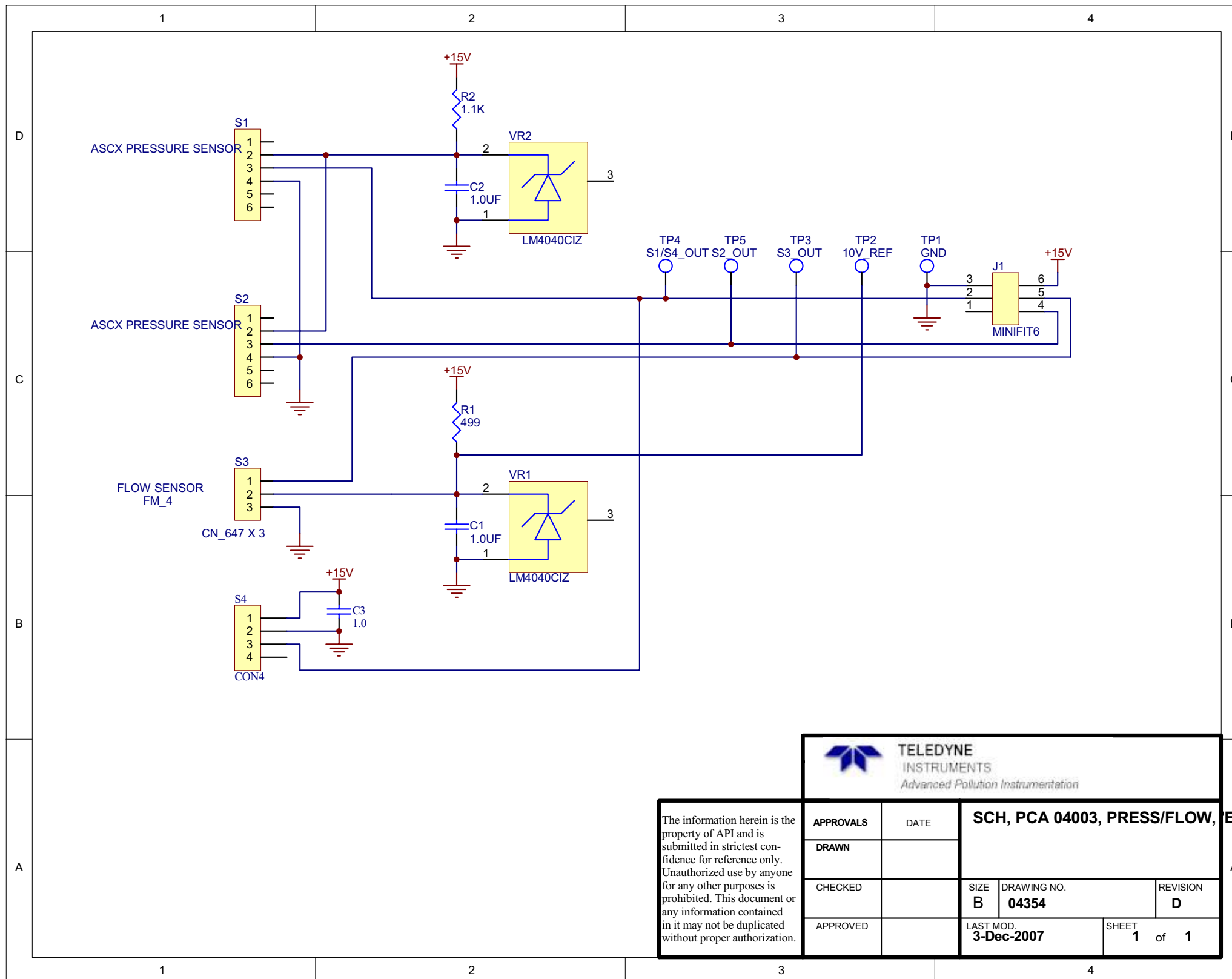

The information herein is the property of API and is submitted in strictest confidence for reference only. Unauthorized use by anyone for any other purposes is prohibited. This document or any information contained in it may not be duplicated without proper authorization.

APPROVALS	DATE	SCH, PCA 04003, PRESS/FLOW, E' SERIES		
DRAWN		SIZE	DRAWING NO.	REVISION
CHECKED		B	04354	D
APPROVED		LAST MOD.	SHEET 1 of 1	
		3-Dec-2007		

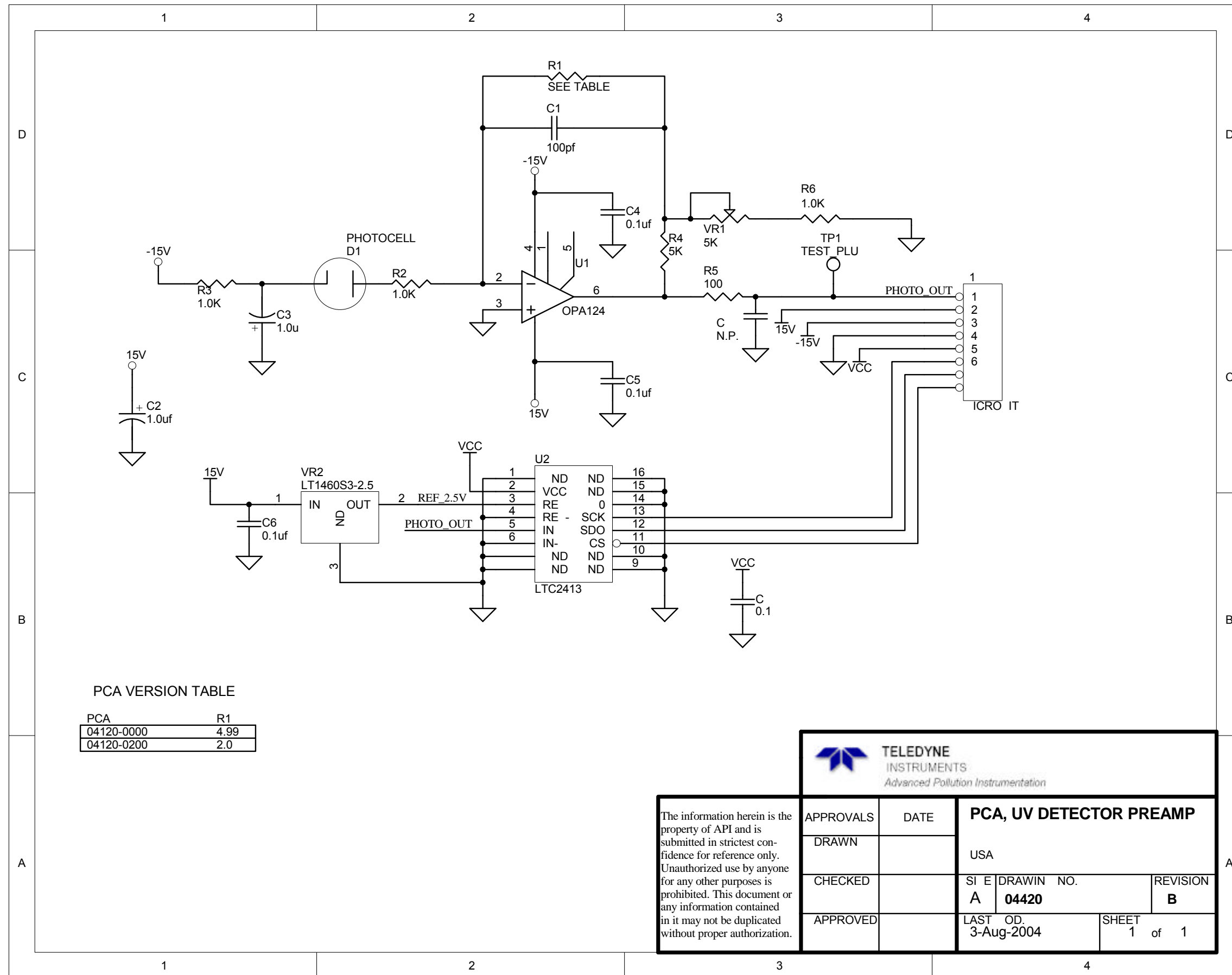

PCA VERSION TABLE

PCA	R1
04120-0000	4.99
04120-0200	2.0

The information herein is the property of API and is submitted in strictest confidence for reference only. Unauthorized use by anyone for any other purposes is prohibited. This document or any information contained in it may not be duplicated without proper authorization.

 TELEDYNE INSTRUMENTS <i>Advanced Pollution Instrumentation</i>			
APPROVALS	DATE	PCA, UV DETECTOR PREAMP	
DRAWN		USA	
CHECKED		SI E DRAWIN NO.	REVISION
APPROVED		A 04420	B
		LAST OD.	SHEET
		3-Aug-2004	1 of 1

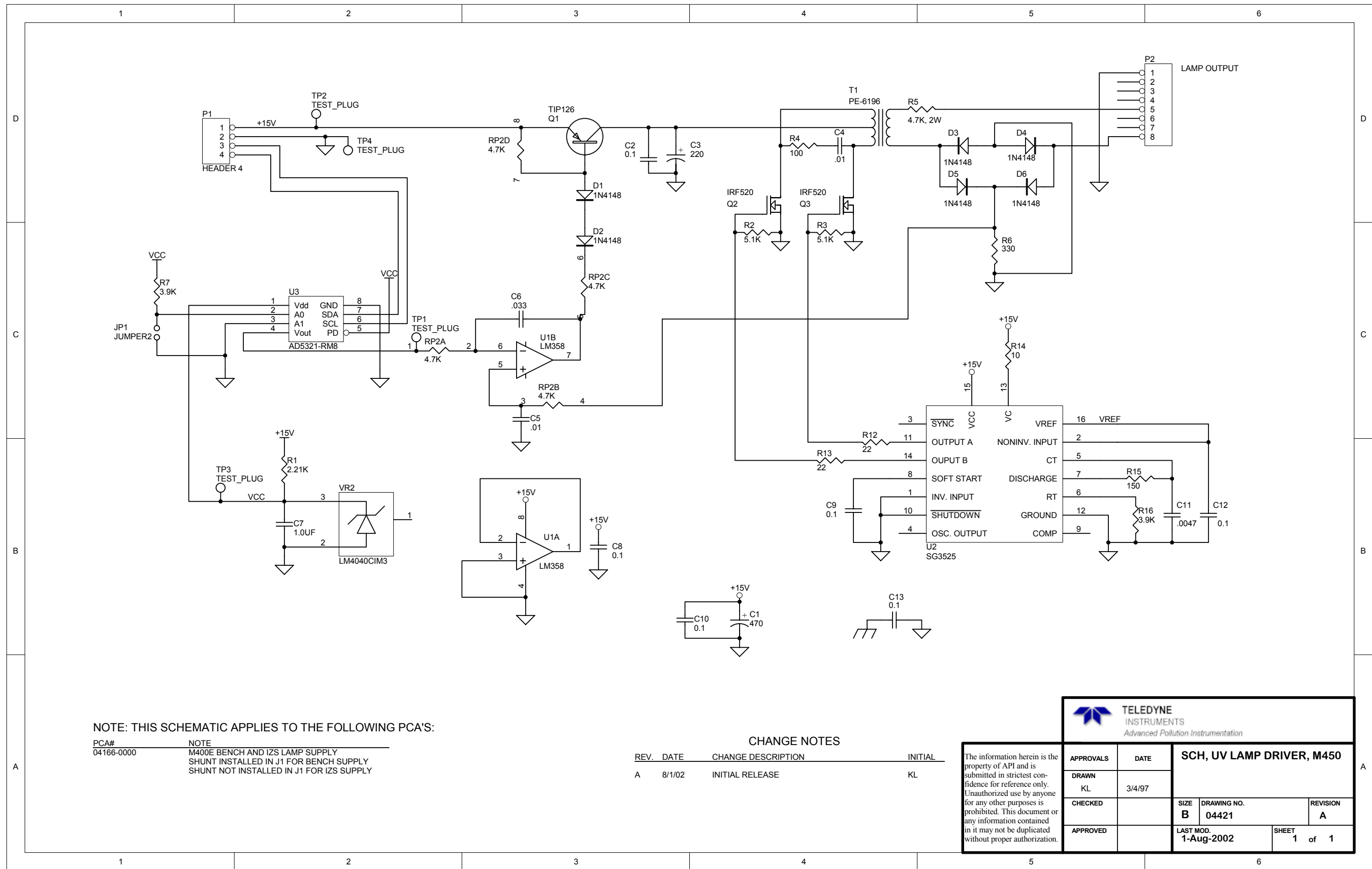

NOTE: THIS SCHEMATIC APPLIES TO THE FOLLOWING PCA'S:

PCA#	NOTE
04166-0000	M400E BENCH AND IZS LAMP SUPPLY SHUNT INSTALLED IN J1 FOR BENCH SUPPLY SHUNT NOT INSTALLED IN J1 FOR IZS SUPPLY

CHANGE NOTES

REV.	DATE	CHANGE DESCRIPTION	INITIAL
A	8/1/02	INITIAL RELEASE	KL

 TELEDYNE INSTRUMENTS <i>Advanced Pollution Instrumentation</i>			
SCH, UV LAMP DRIVER, M450			
APPROVALS	DATE	SIZE	DRAWING NO.
DRAWN	3/4/97	B	04421
CHECKED			REVISION A
APPROVED		LAST MOD.	SHEET
		1-Aug-2002	1 of 1

The information herein is the property of API and is submitted in strictest confidence for reference only. Unauthorized use by anyone for any other purposes is prohibited. This document or any information contained in it may not be duplicated without proper authorization.

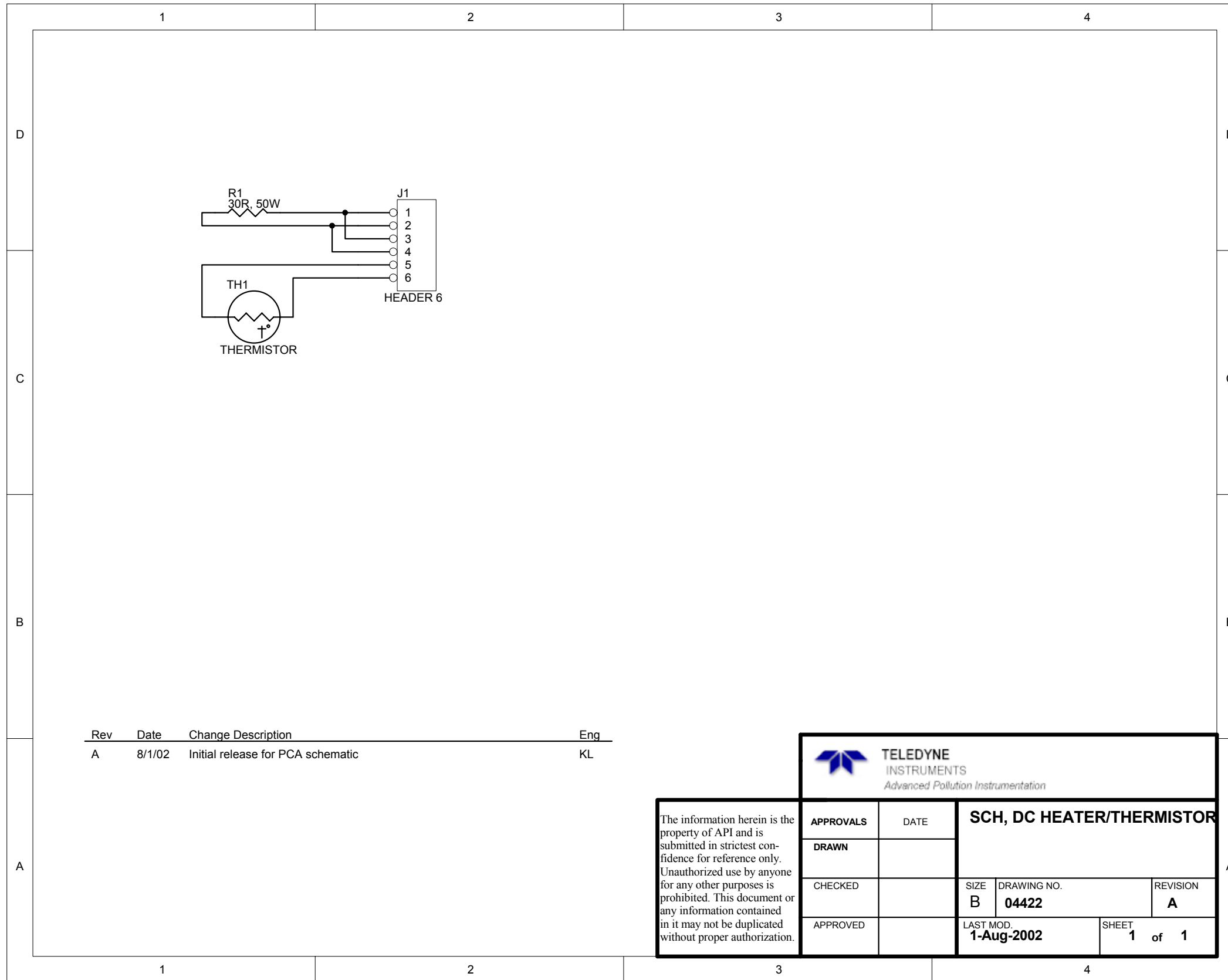

Rev	Date	Change Description	Eng
A	8/1/02	Initial release for PCA schematic	KL

 TELEDYNE INSTRUMENTS <i>Advanced Pollution Instrumentation</i>									
The information herein is the property of API and is submitted in strictest confidence for reference only. Unauthorized use by anyone for any other purposes is prohibited. This document or any information contained in it may not be duplicated without proper authorization.	APPROVALS	DATE	SCH, DC HEATER/THERMISTOR						
	DRAWN								
	CHECKED		<table border="1" style="width: 100%;"> <tr> <td style="font-size: small;">SIZE</td> <td style="font-size: small;">DRAWING NO.</td> <td style="font-size: small;">REVISION</td> </tr> <tr> <td style="text-align: center;">B</td> <td style="text-align: center;">04422</td> <td style="text-align: center;">A</td> </tr> </table>	SIZE	DRAWING NO.	REVISION	B	04422	A
	SIZE	DRAWING NO.	REVISION						
B	04422	A							
APPROVED		<table border="1" style="width: 100%;"> <tr> <td style="font-size: small;">LAST MOD.</td> <td style="font-size: small;">SHEET</td> </tr> <tr> <td style="text-align: center;">1-Aug-2002</td> <td style="text-align: center;">1 of 1</td> </tr> </table>	LAST MOD.	SHEET	1-Aug-2002	1 of 1			
LAST MOD.	SHEET								
1-Aug-2002	1 of 1								

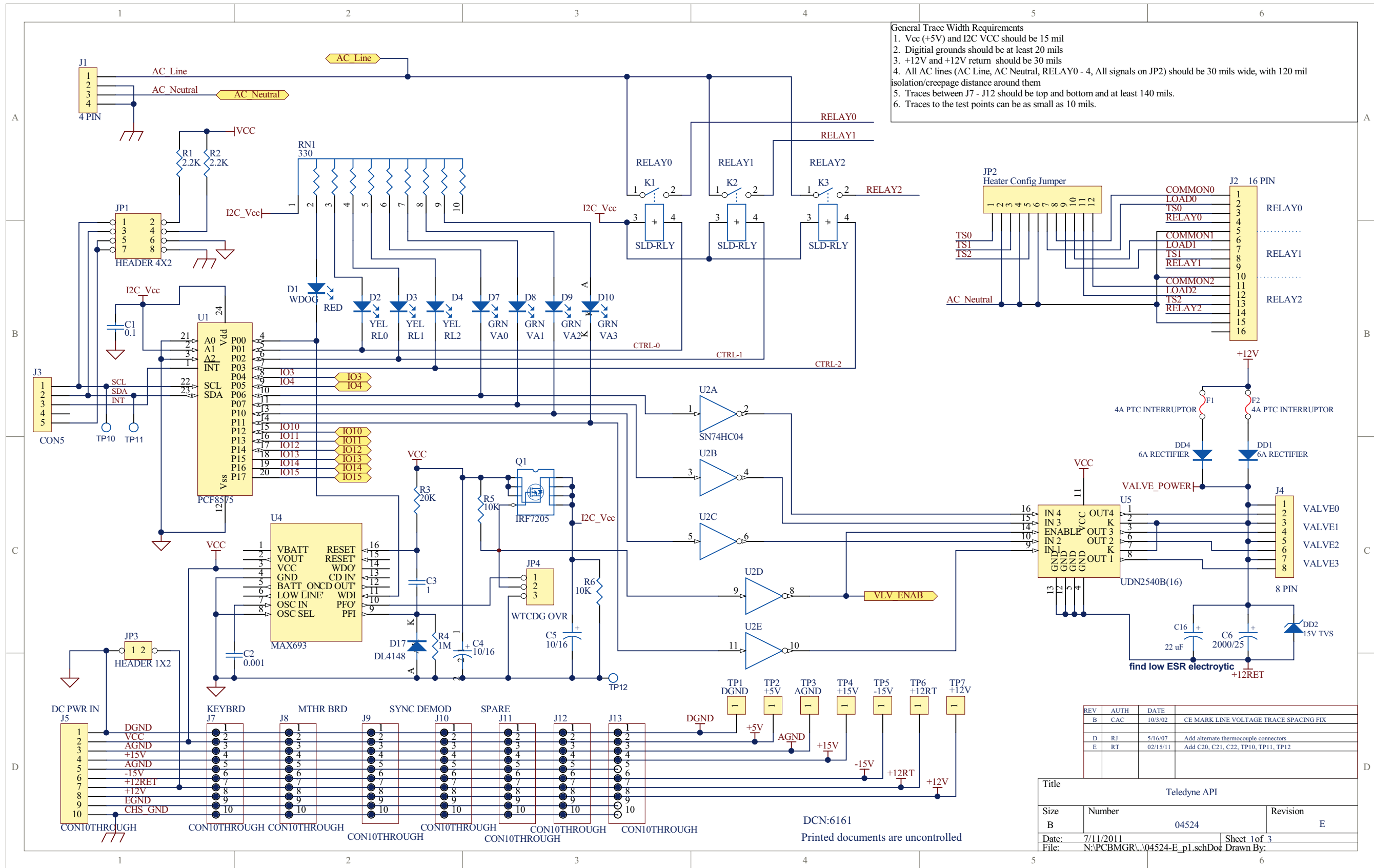

General Trace Width Requirements

1. Vcc (+5V) and I2C VCC should be 15 mil
2. Digital grounds should be at least 20 mils
3. +12V and +12V return should be 30 mils
4. All AC lines (AC Line, AC Neutral, RELAY0 - 4, All signals on JP2) should be 30 mils wide, with 120 mil isolation/creepage distance around them
5. Traces between J7 - J12 should be top and bottom and at least 140 mils.
6. Traces to the test points can be as small as 10 mils.

REV	AUTH	DATE	DESCRIPTION
B	CAC	10/3/02	CE MARK LINE VOLTAGE TRACE SPACING FIX
D	RJ	5/16/07	Add alternate thermocouple connectors
E	RT	02/15/11	Add C20, C21, C22, TP10, TP11, TP12

Title			Teledyne API		
Size	Number	Revision			
B	04524	E			
Date:	7/11/2011	Sheet 1 of 3			
File:	N:\PCBMGR\...04524-E_p1.sch	Doc		Drawn By:	

DCN:6161
Printed documents are uncontrolled

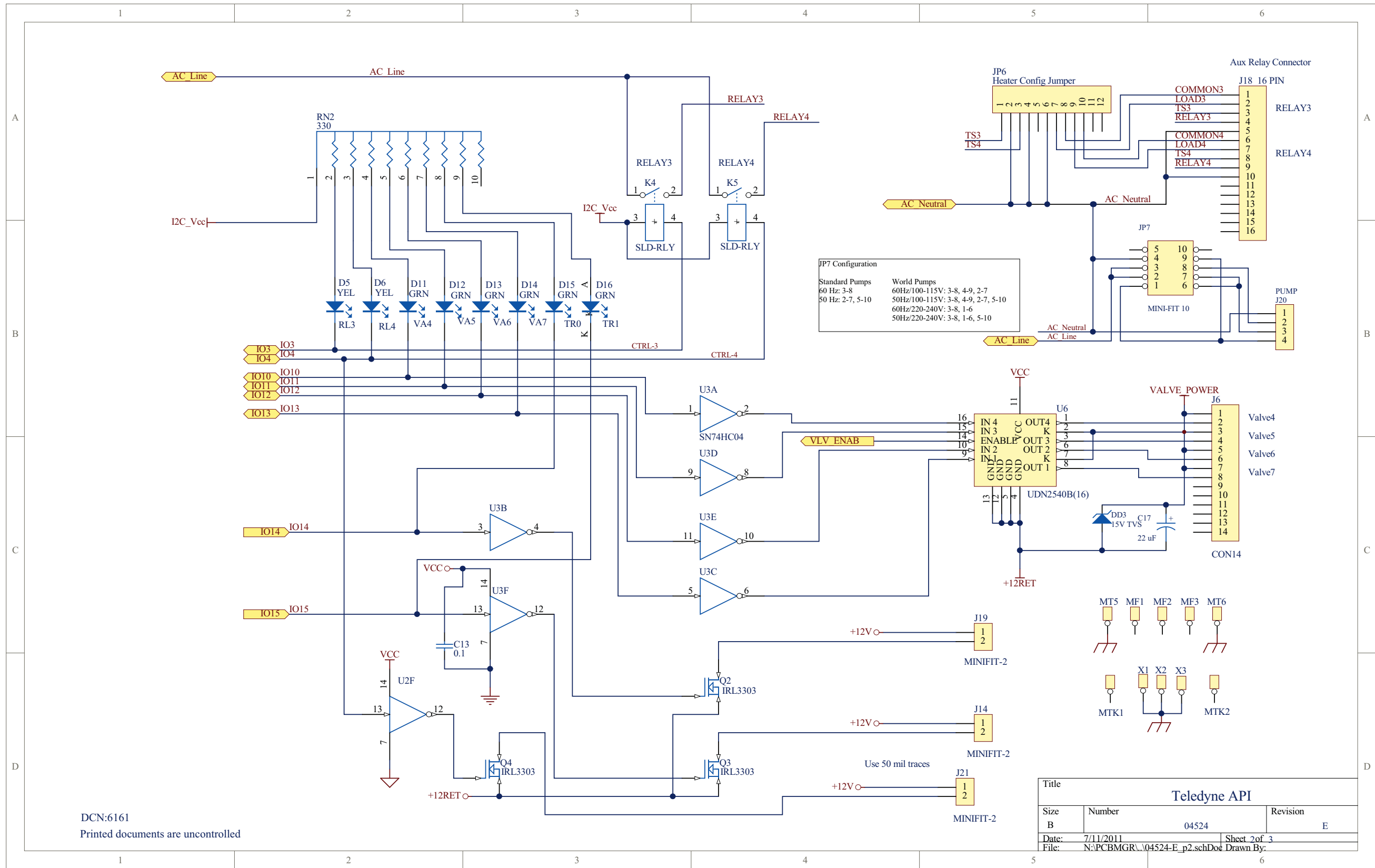

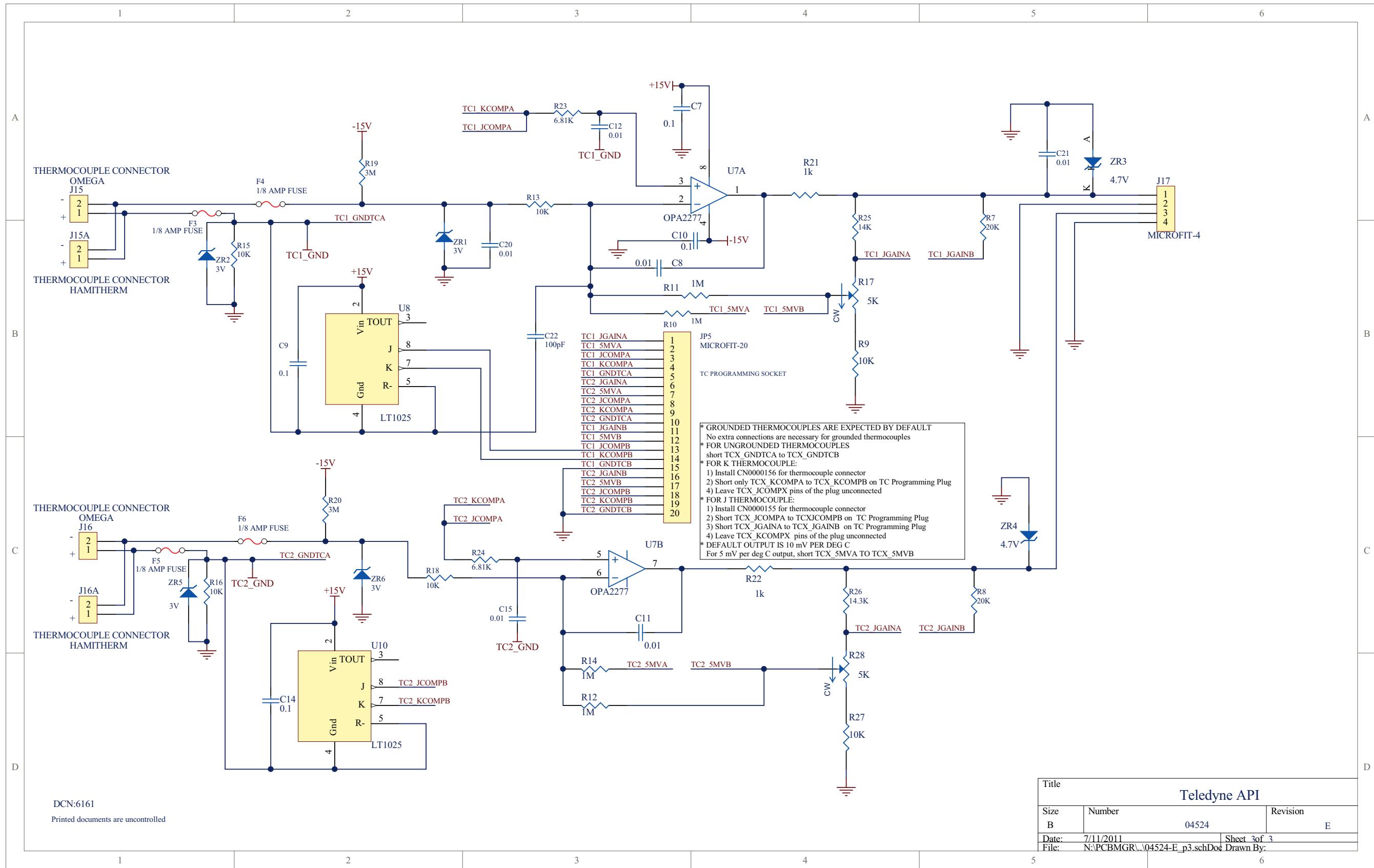

Title			Teledyne API		
Size	Number	Revision			
B	04524	E			
Date:	7/11/2011	Sheet 3 of 3			
File:	N:\PCBMGR\...04524-E_p3.sch	Drawn By:			

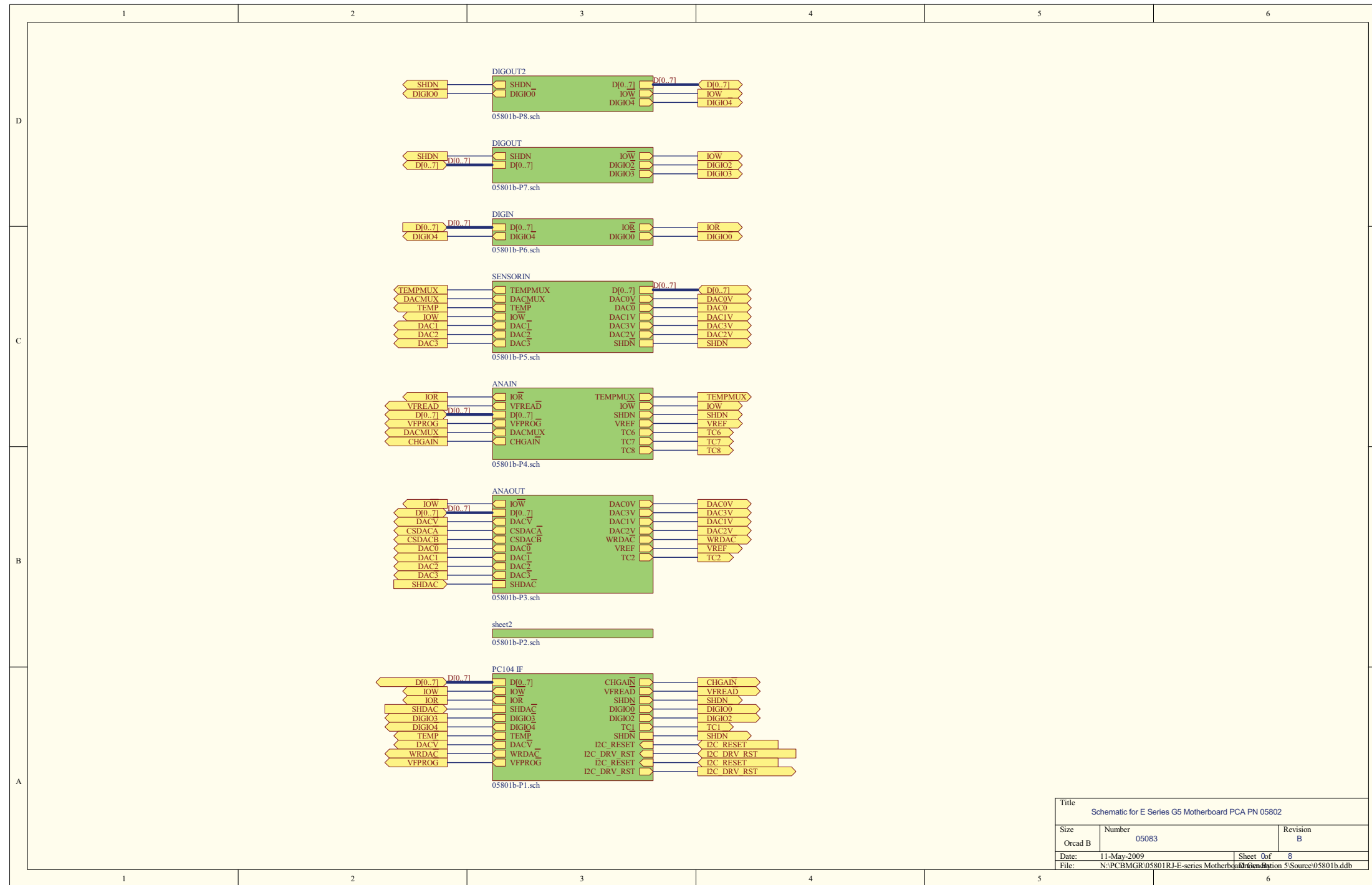

Title		
Schematic for E Series G5 Motherboard PCA PN 05802		
Size	Number	Revision
Orcaid B	05083	B
Date:	11-May-2009	Sheet Of 8
File:	N:\PCBMGR\05801RJ-E-series Motherboard\05801b.ddb	

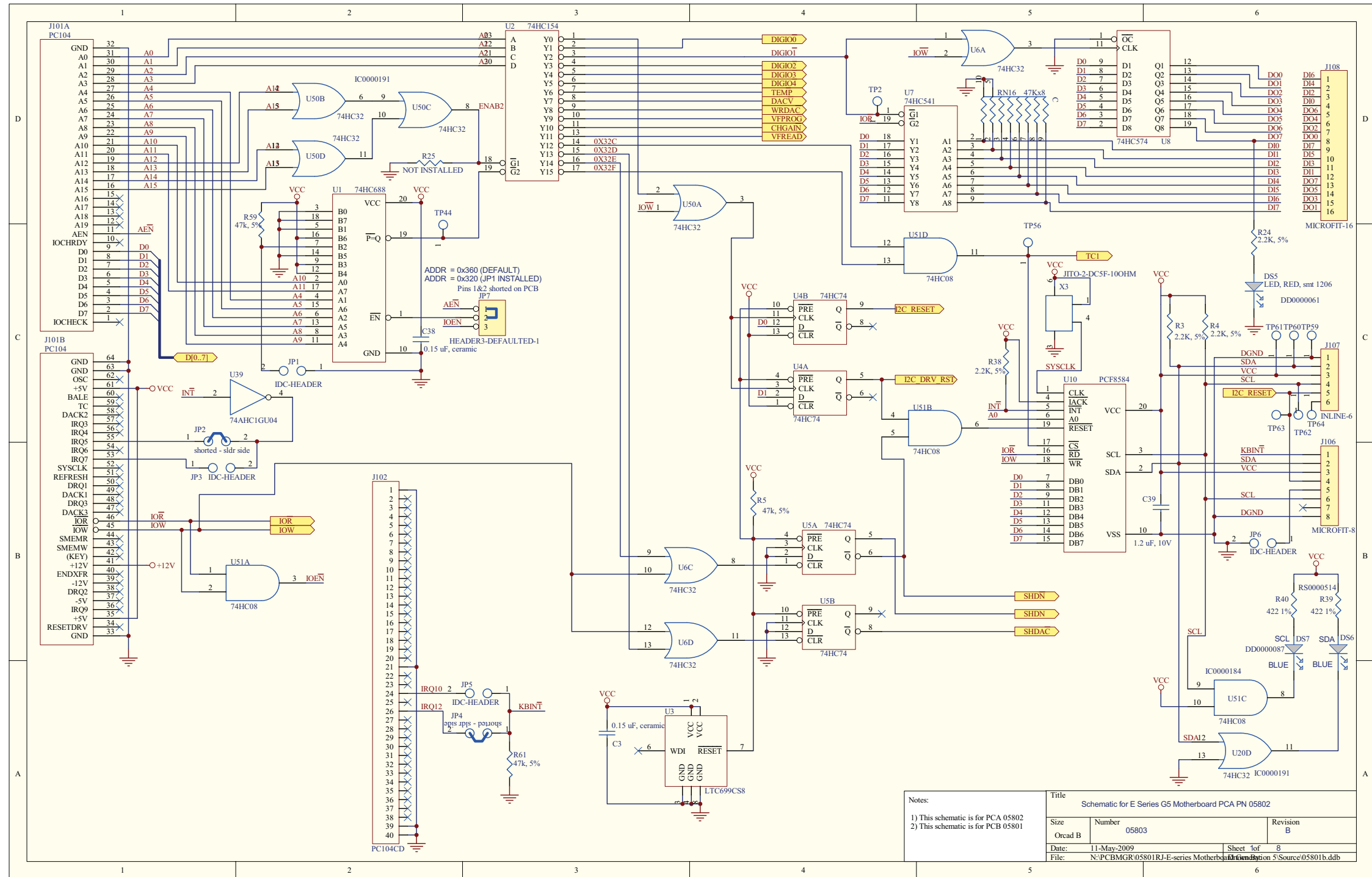

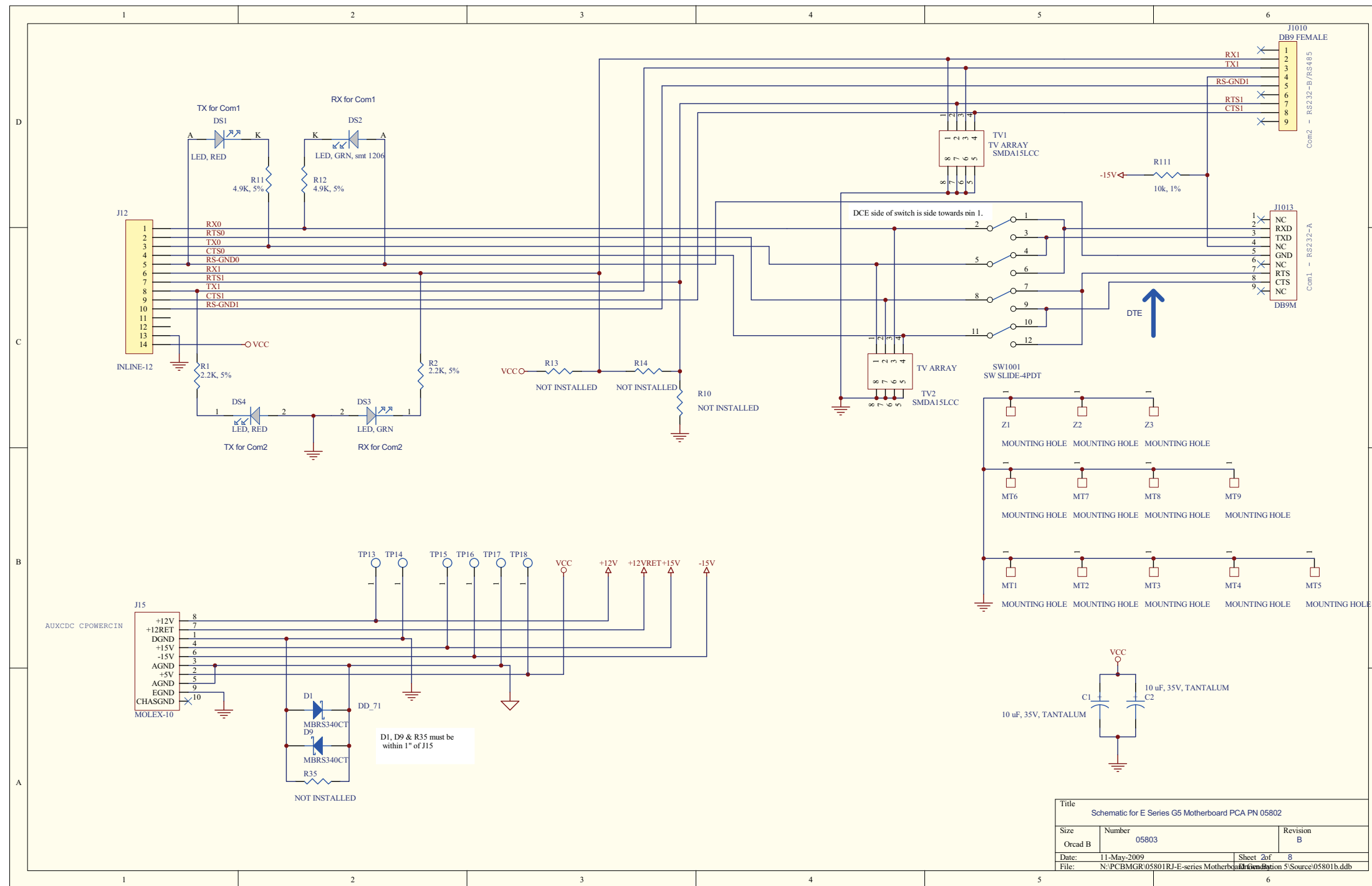

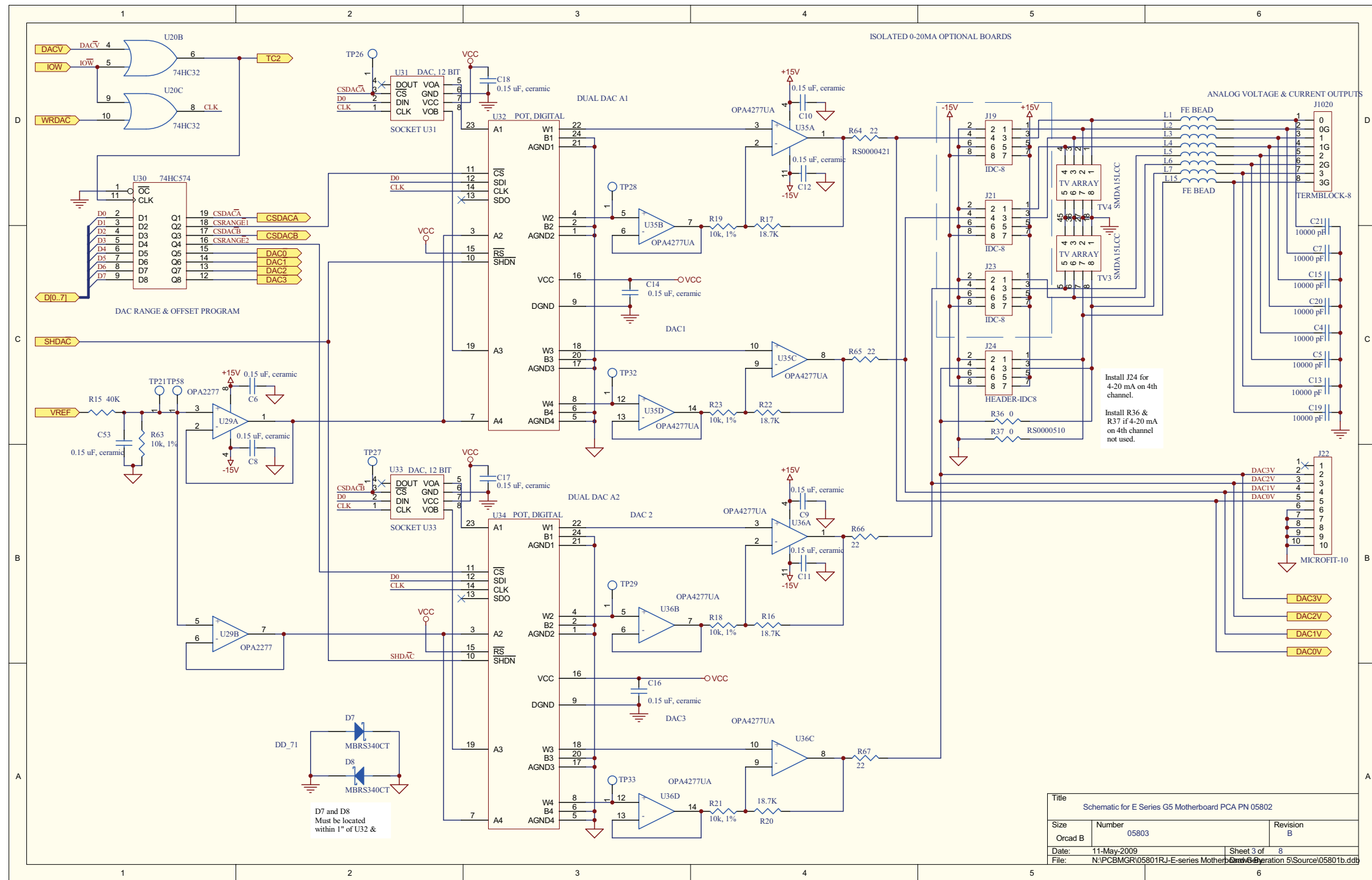

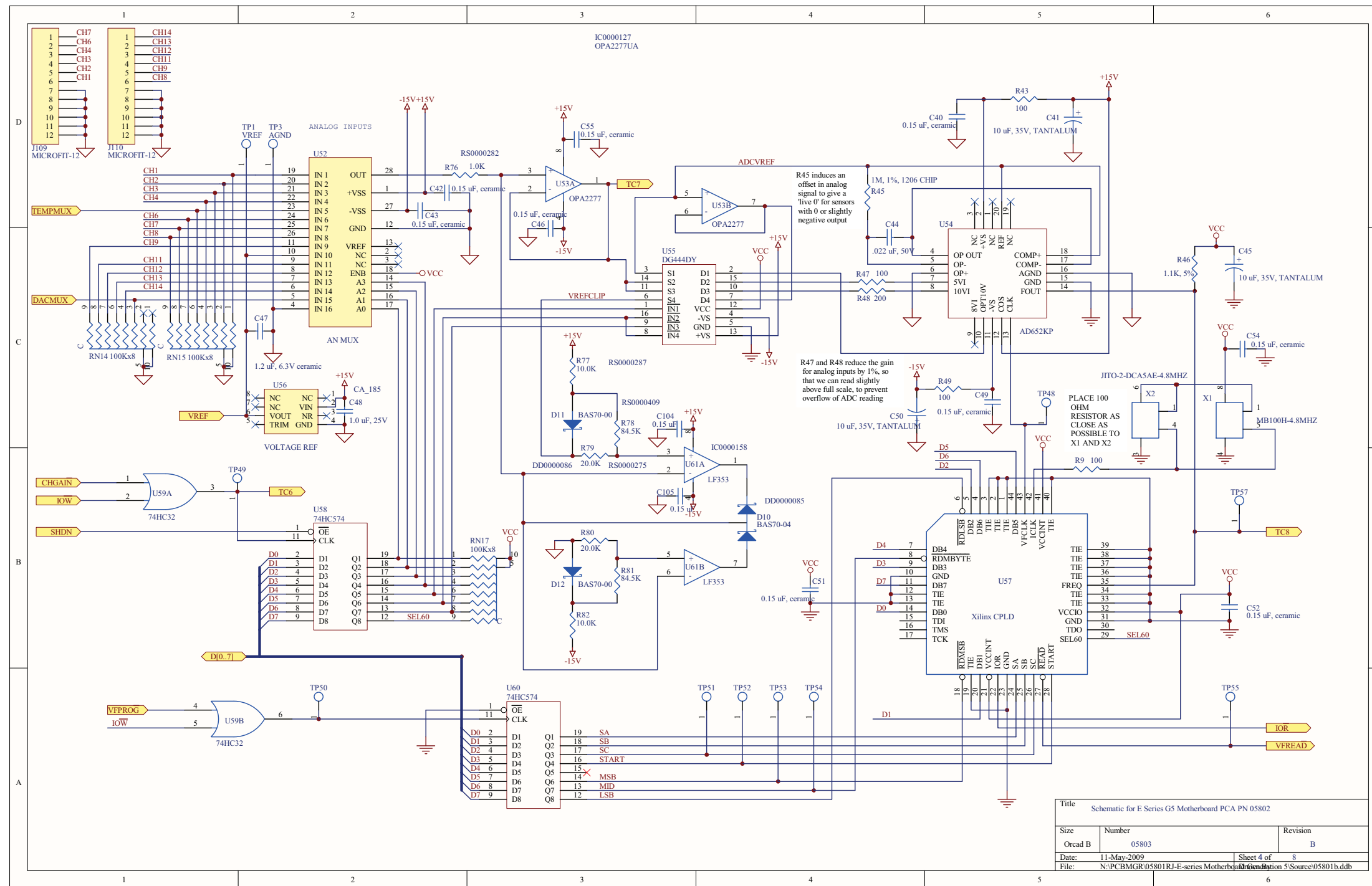

Title		
Schematic for E Series G5 Motherboard PCA PN 05802		
Size	Number	Revision
Orcad B	05803	B
Date:	11-May-2009	Sheet 4 of 8
File:	N:\PCBMGR\05801RJ-E-series Motherboard\05801b.ddb	

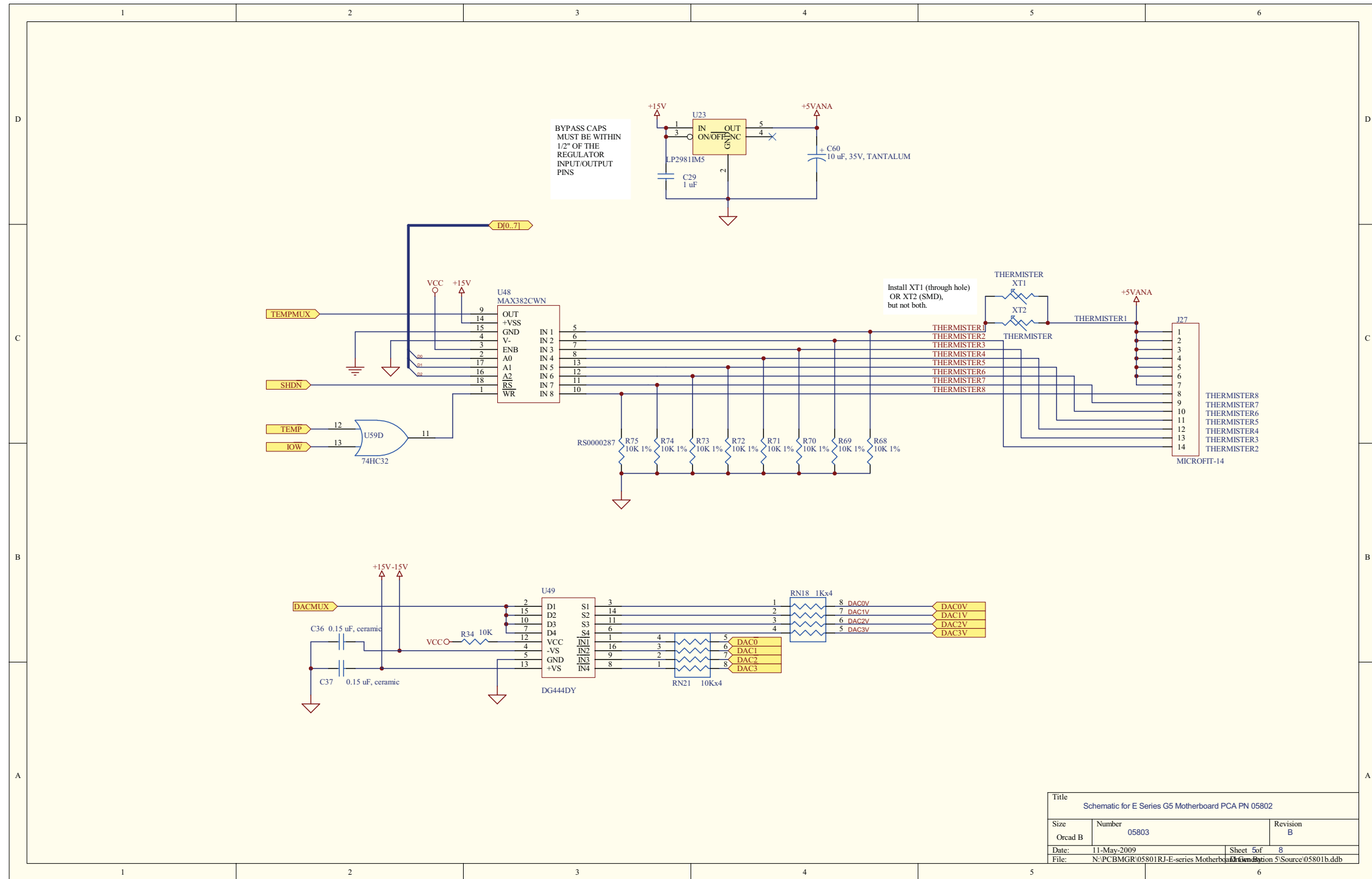

Title		
Schematic for E Series G5 Motherboard PCA PN 05802		
Size	Number	Revision
Orcad B	05803	B
Date:	11-May-2009	Sheet 5 of 8
File:	N:\PCBMGR\05801RJ-E-series Motherboard\05801b.ddb	

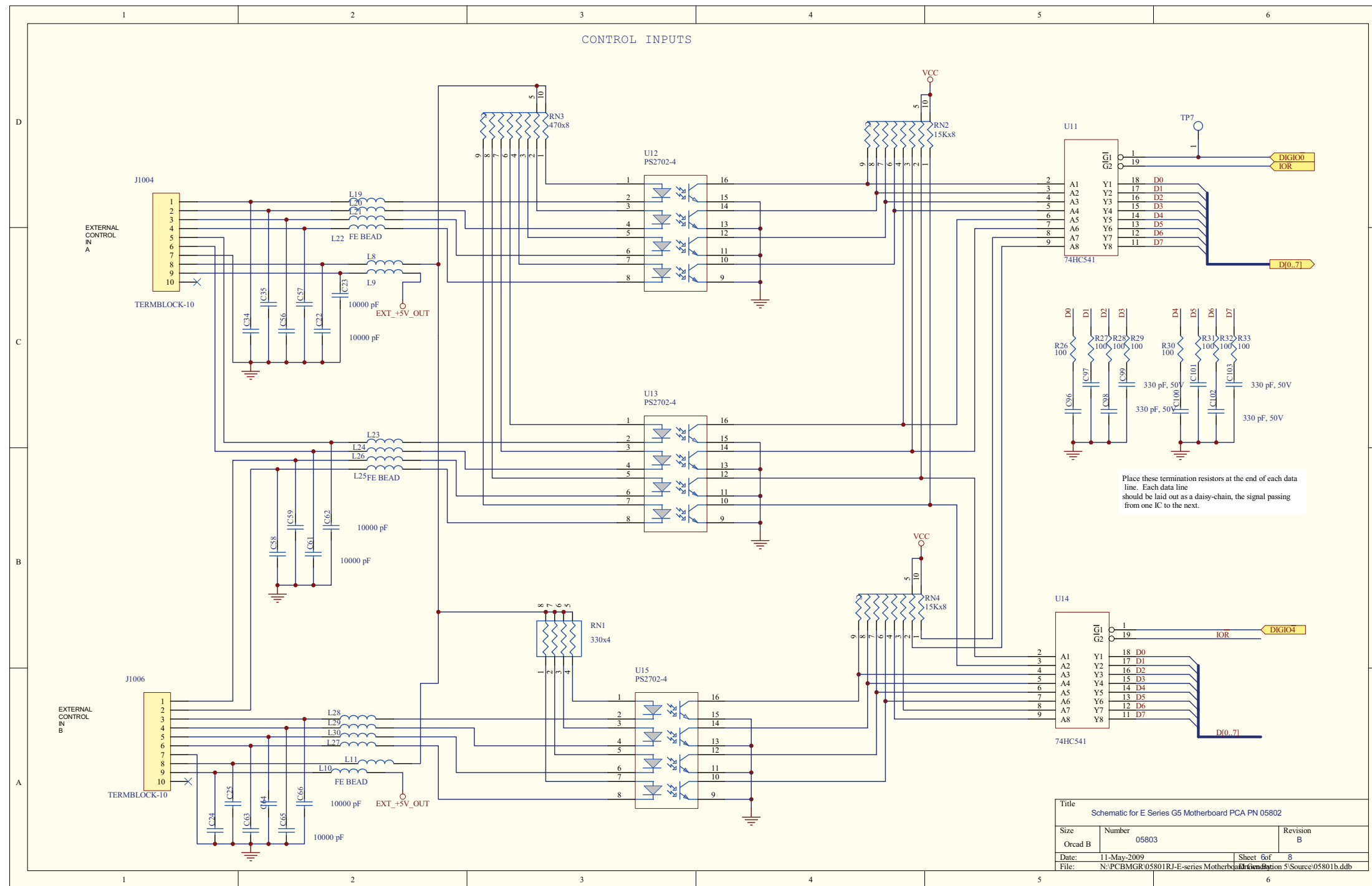

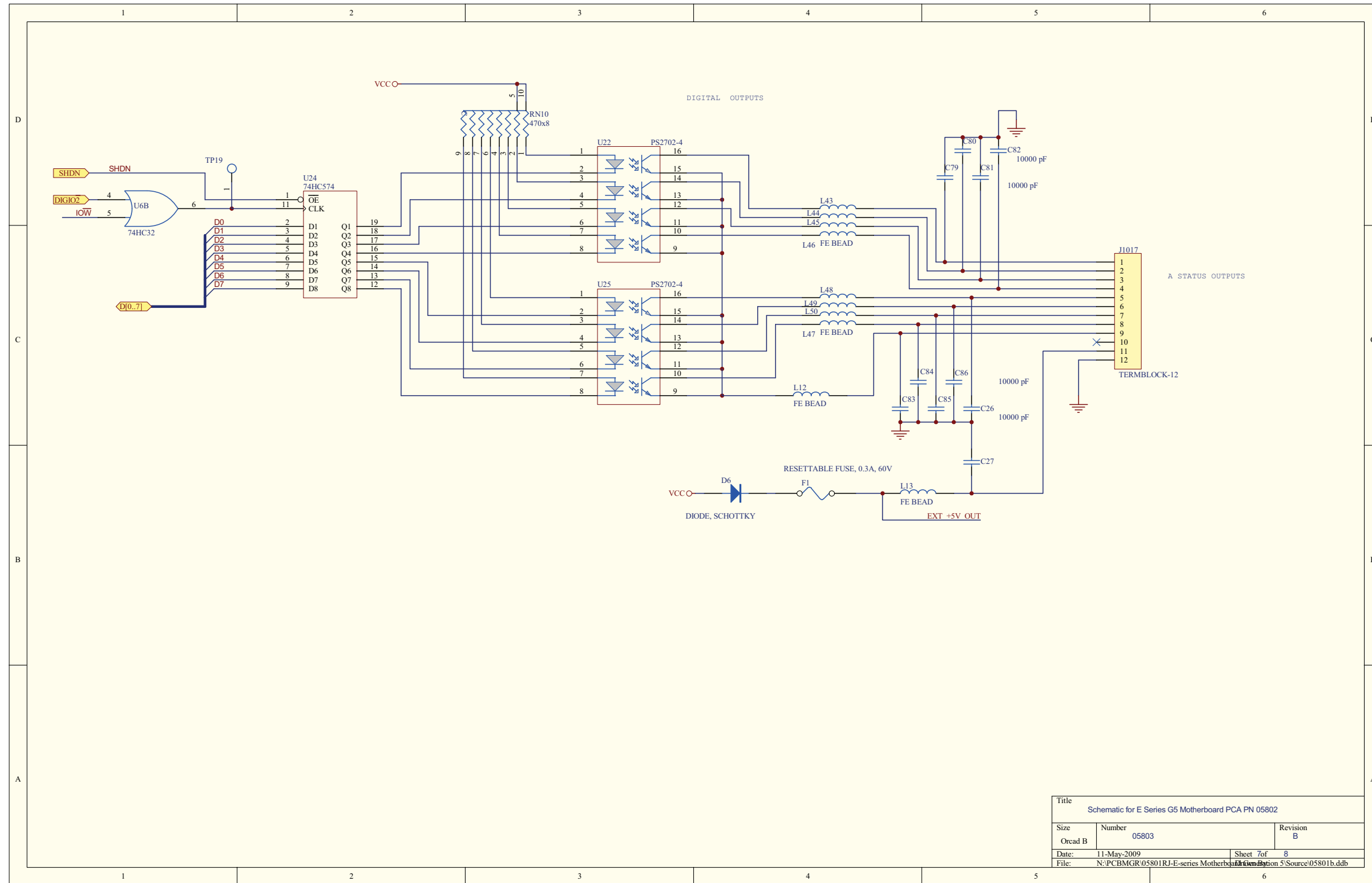

Title		
Schematic for E Series G5 Motherboard PCA PN 05802		
Size	Number	Revision
Orcad B	05803	B
Date:	11-May-2009	Sheet 7 of 8
File:	N:\PCBMGR\05801RJ-E-series Motherboards\05801b.ddb	

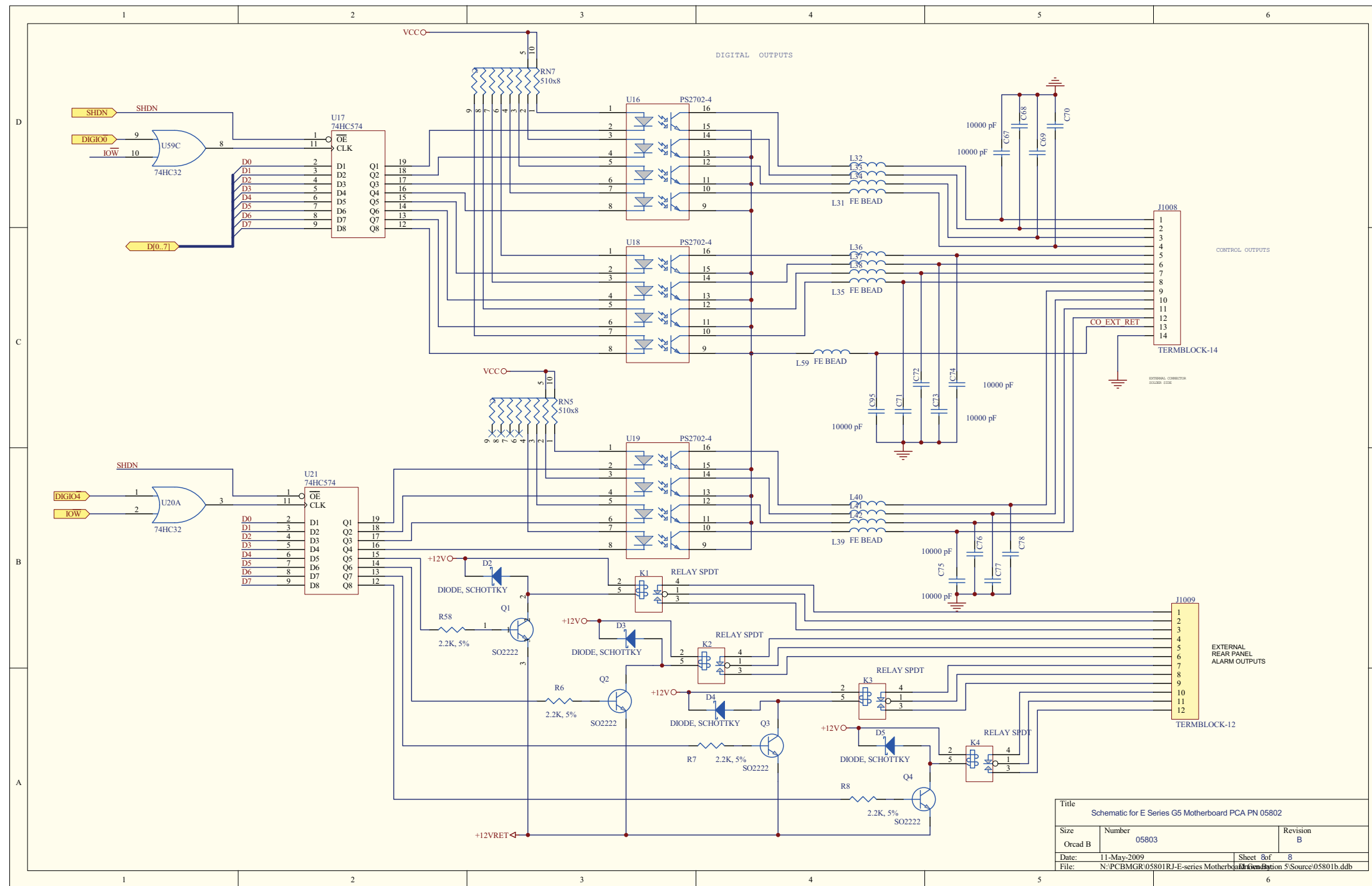

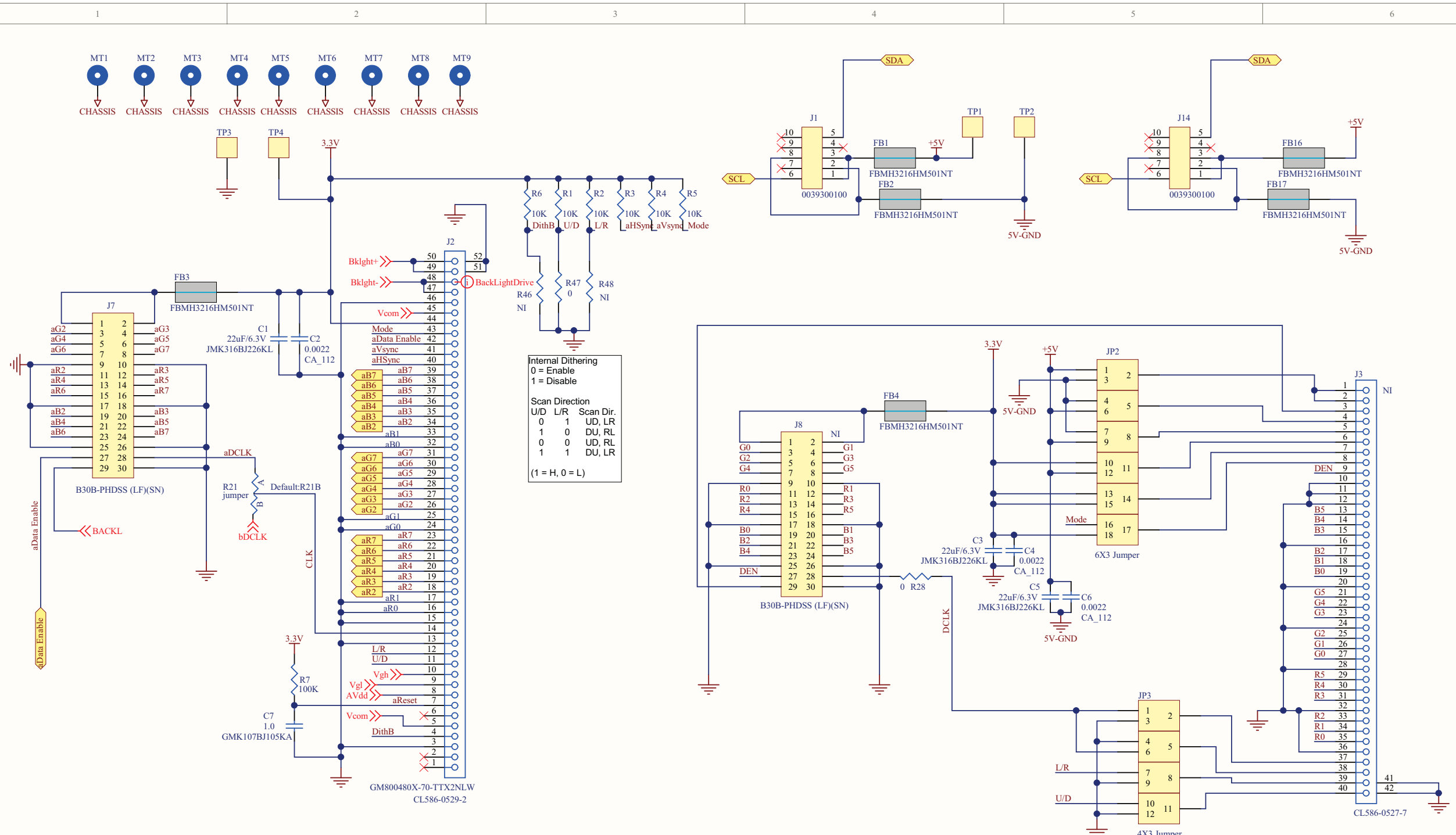

Internal Dithering
 0 = Enable
 1 = Disable

Scan Direction
 U/D L/R Scan Dir.
 0 1 UD, LR
 1 0 DU, RL
 0 0 UD, RL
 1 1 DU, LR
 (1 = H, 0 = L)

Make	Model	JP2	JP3
FEMA	GM800480W	1-2, 4-5, 7-8, 10-11, 13-14, 16-17	1-2, 4-5, 7-8, 10-11
Data Image	FG0700A0DSWBG01	3-2, 6-5, 9-8, 12-11, 15-14, 18-17	2-3, 5-6, 8-9, 11-12
United Radiant Tech.	UMSH-8173MD-1T	2-3, 4/5/6 NC, 7/8/9 NC, 10-11, 13-14, 16/17/18 NC	2-3, 5-6, 8-9, 11-12

Title			GUI Interface		
Size	Number	Revision			
B	06698	D			
Date:	6/24/2010	Sheet 1 of 4			
File:	N:\PCBMGRU\06696.P1.R3.schdoc	Drawn By: RT			

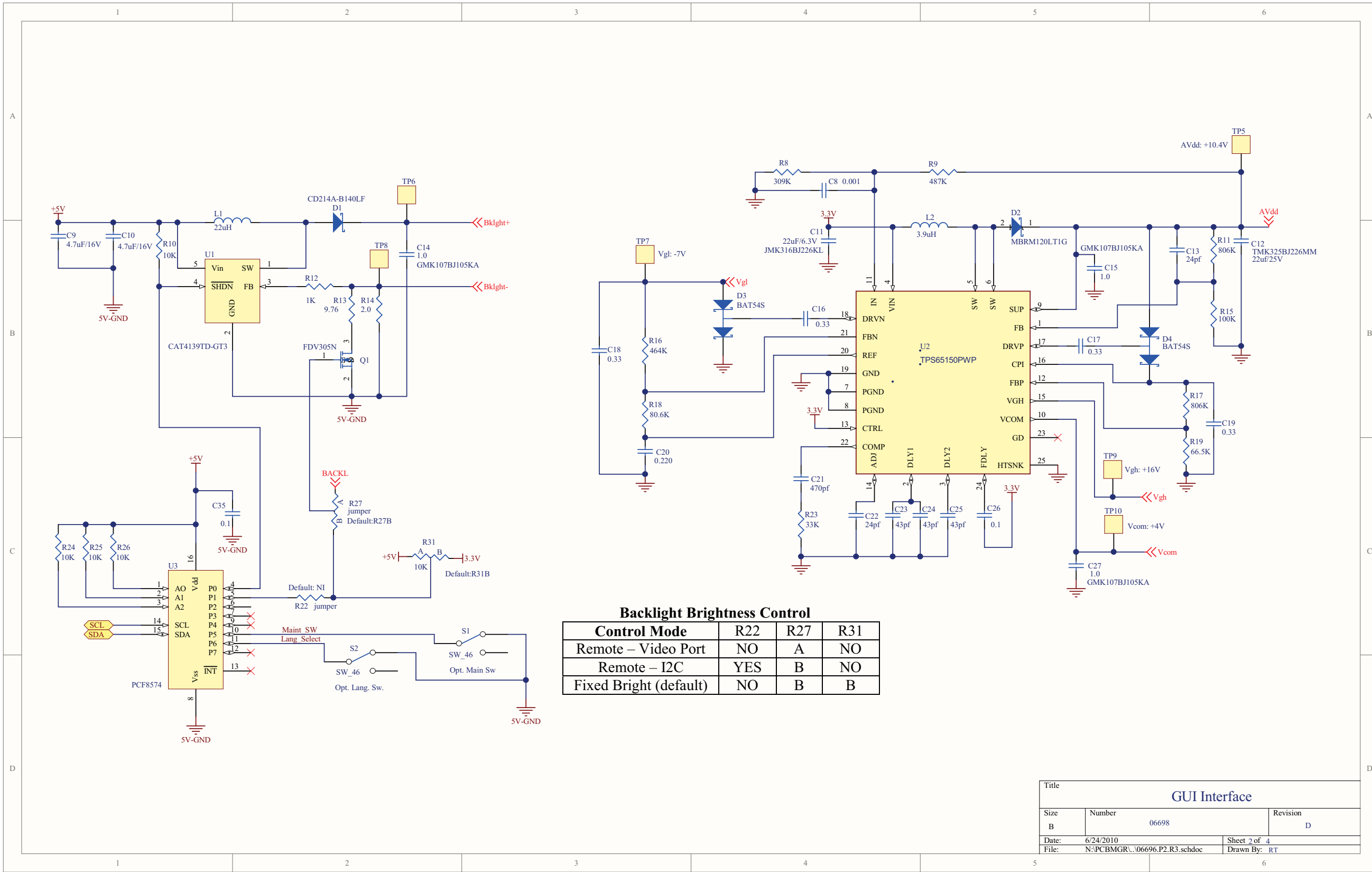

Backlight Brightness Control

Control Mode	R22	R27	R31
Remote – Video Port	NO	A	NO
Remote – I2C	YES	B	NO
Fixed Bright (default)	NO	B	B

Title			GUI Interface		
Size	Number	Revision			
B	06698	D			
Date:	6/24/2010	Sheet 2 of 4			
File:	N:\PCBMGR\...06696.P2.R3.schdoc	Drawn By:	RT		

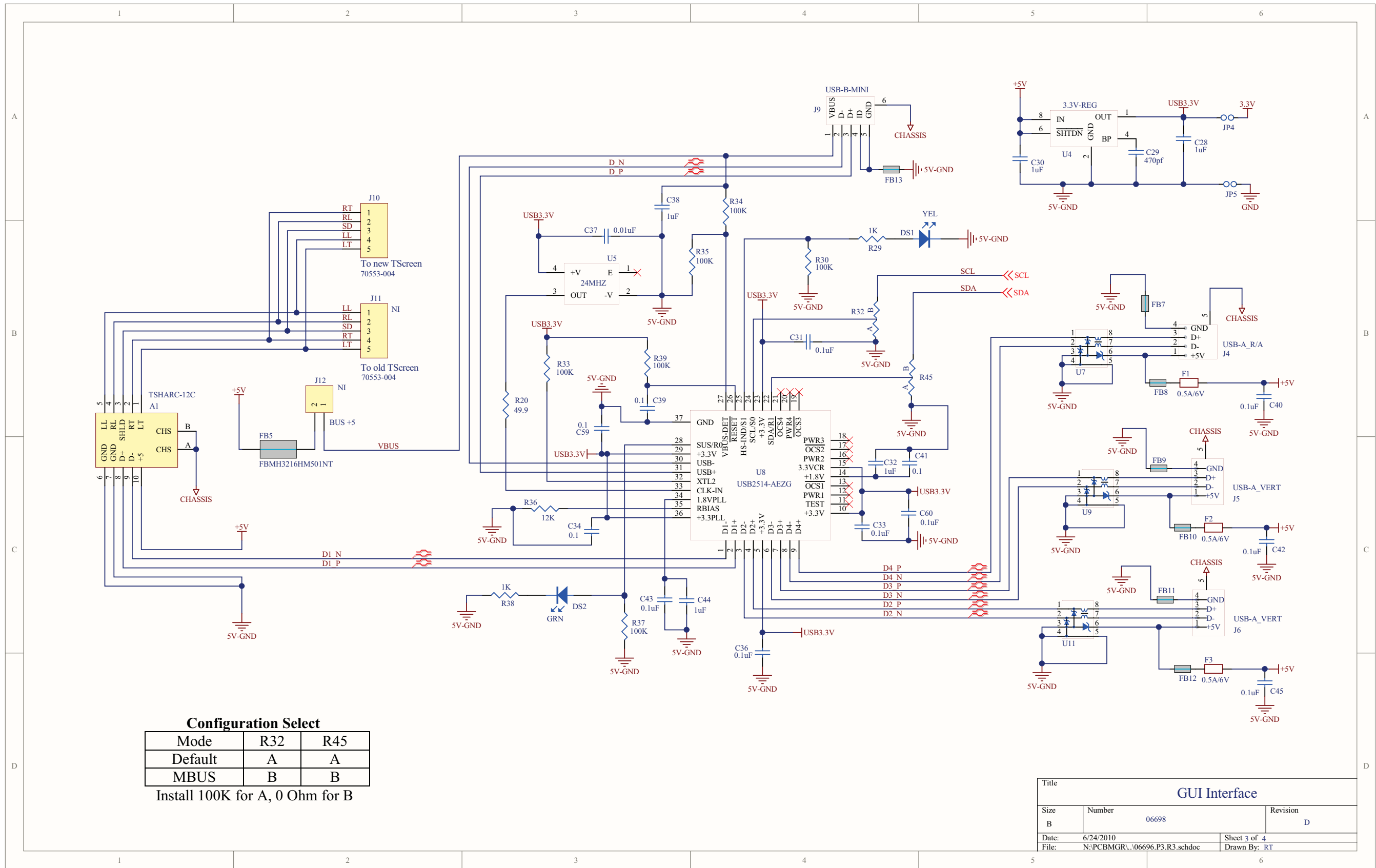

Configuration Select

Mode	R32	R45
Default	A	A
MBUS	B	B

Install 100K for A, 0 Ohm for B

Title			GUI Interface		
Size	Number	Revision			
B	06698	D			
Date:	6/24/2010	Sheet 3 of 4			
File:	N:\PCBMGRU\06696.P3.R3.schdoc	Drawn By: RT			

TOUCH SCREEN INTERFACE CIRCUITRY (TBD)

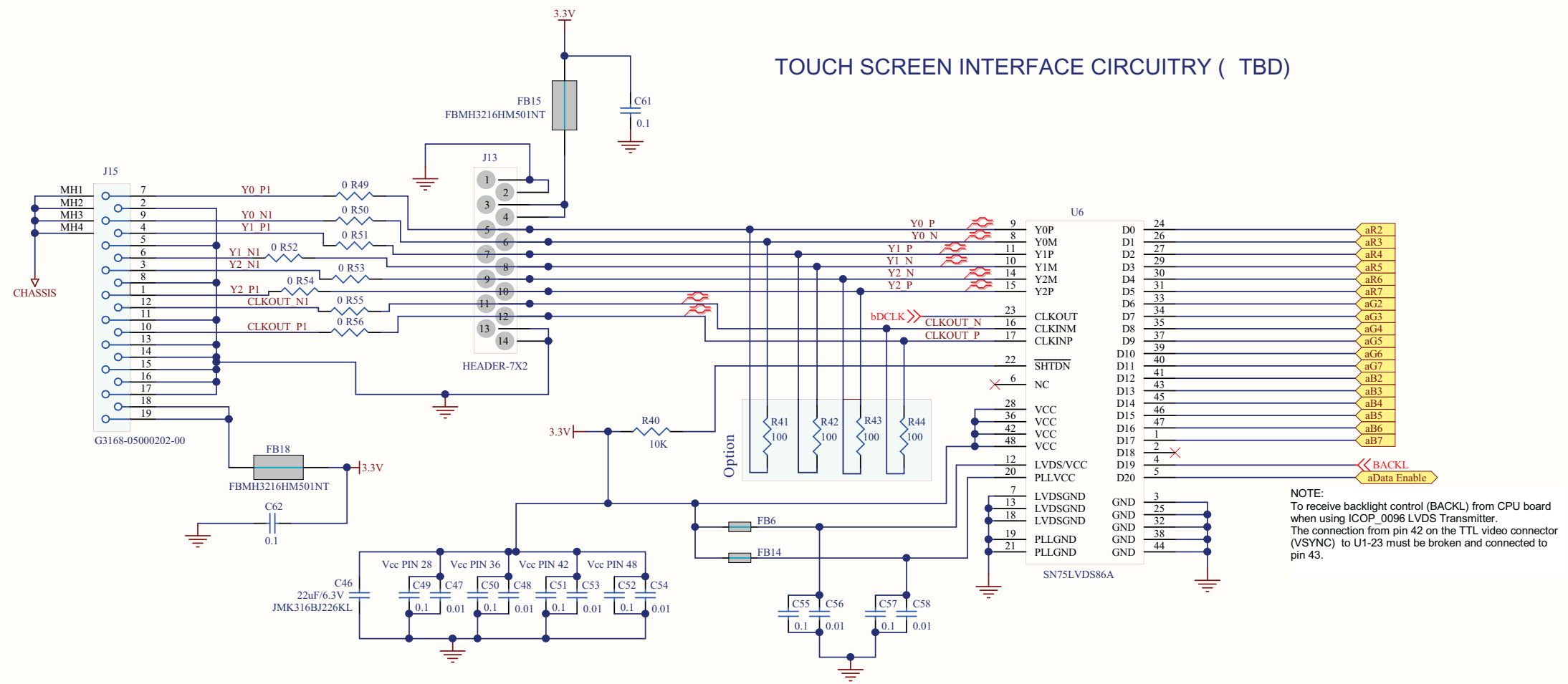

Title		
GUI Interface		
Size	Number	Revision
B	06698	D
Date:	6/24/2010	Sheet 4 of 4
File:	N:\PCBMGR\...06696.P4.R3.schdoc	Drawn By: RT

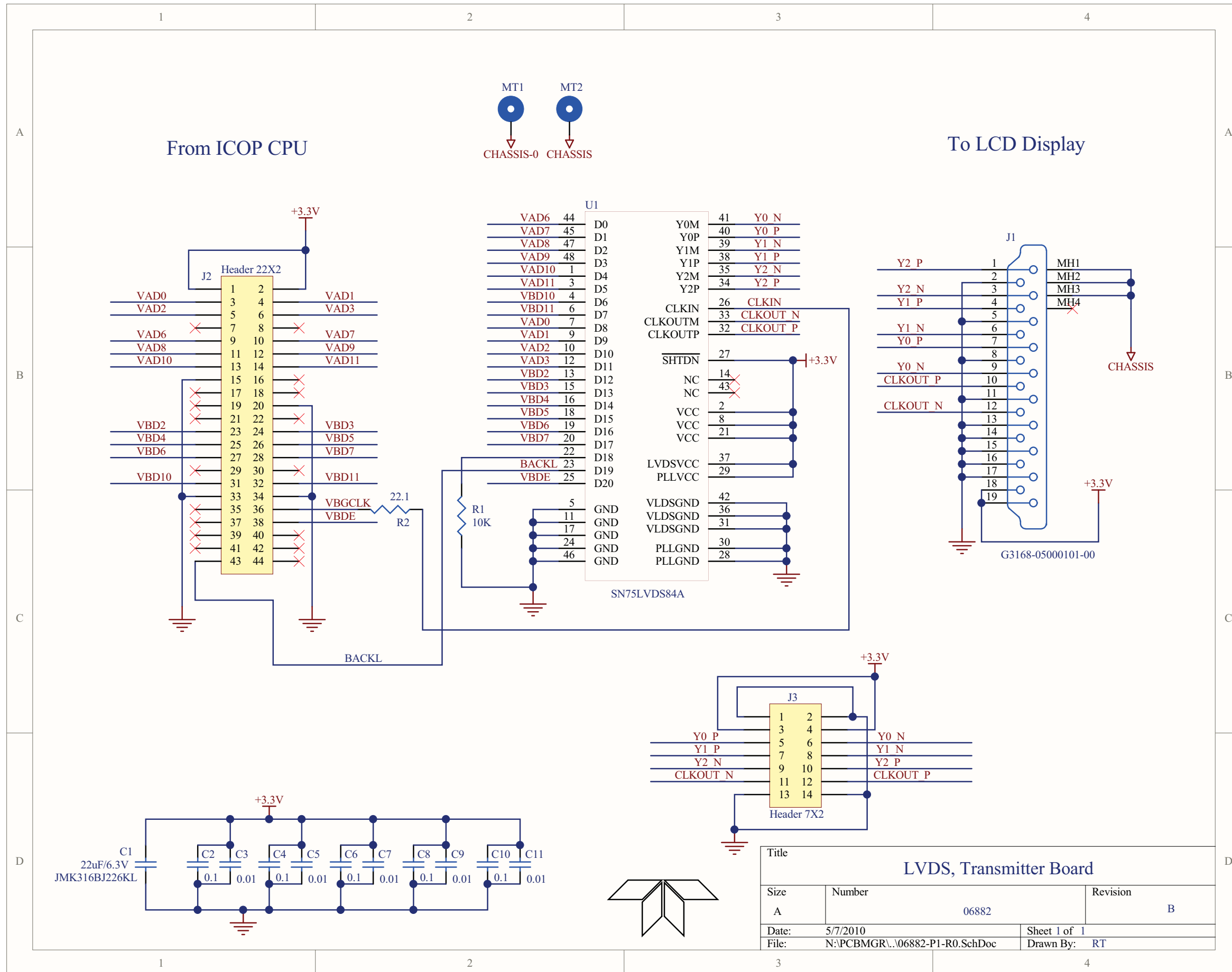

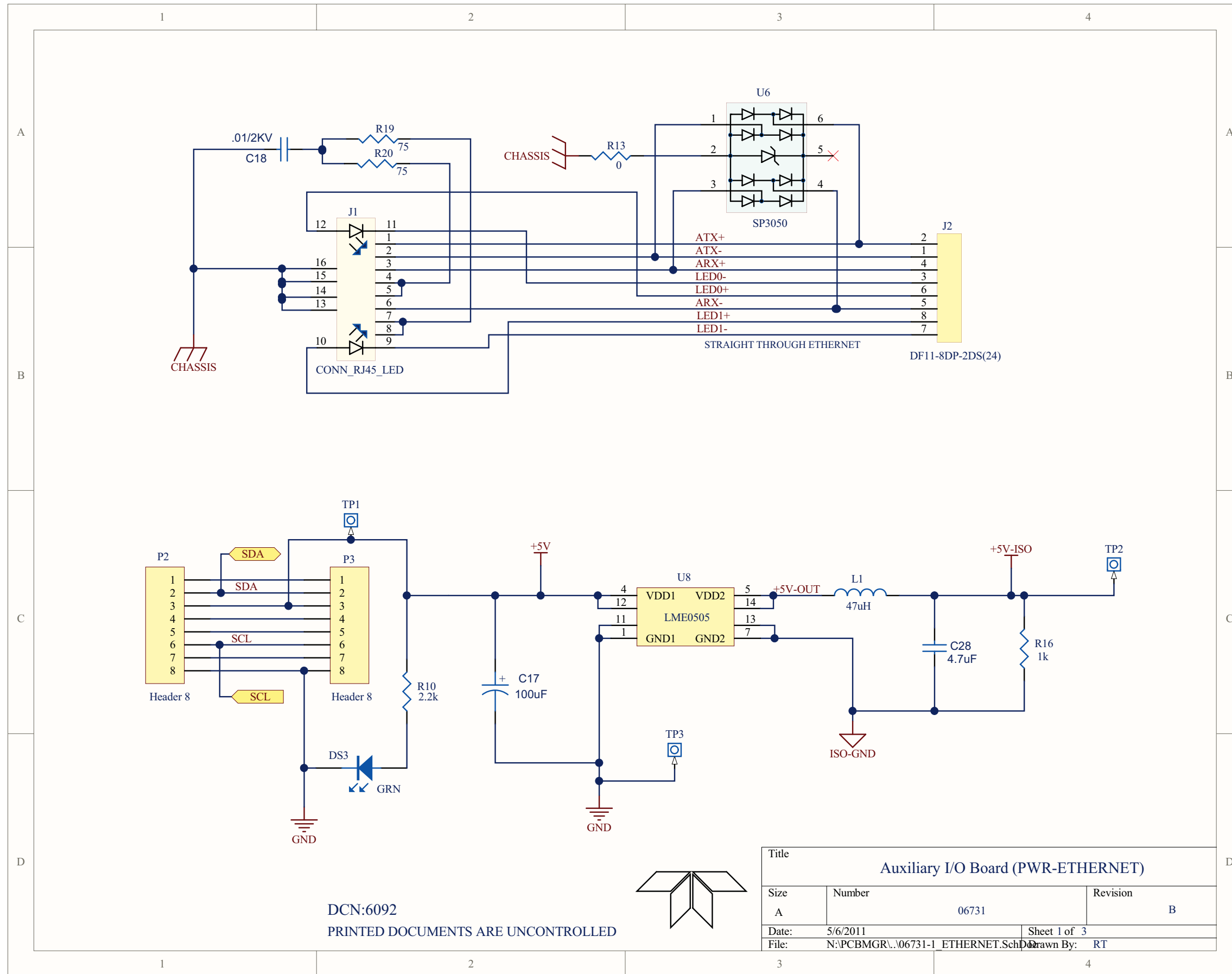

DCN:6092
 PRINTED DOCUMENTS ARE UNCONTROLLED

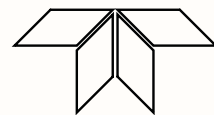

Title		
Auxiliary I/O Board (PWR-ETHERNET)		
Size	Number	Revision
A	06731	B
Date:	5/6/2011	Sheet 1 of 3
File:	N:\PCBMGR\...06731-1 ETHERNET.SchDoc	
Drawn By:	RT	

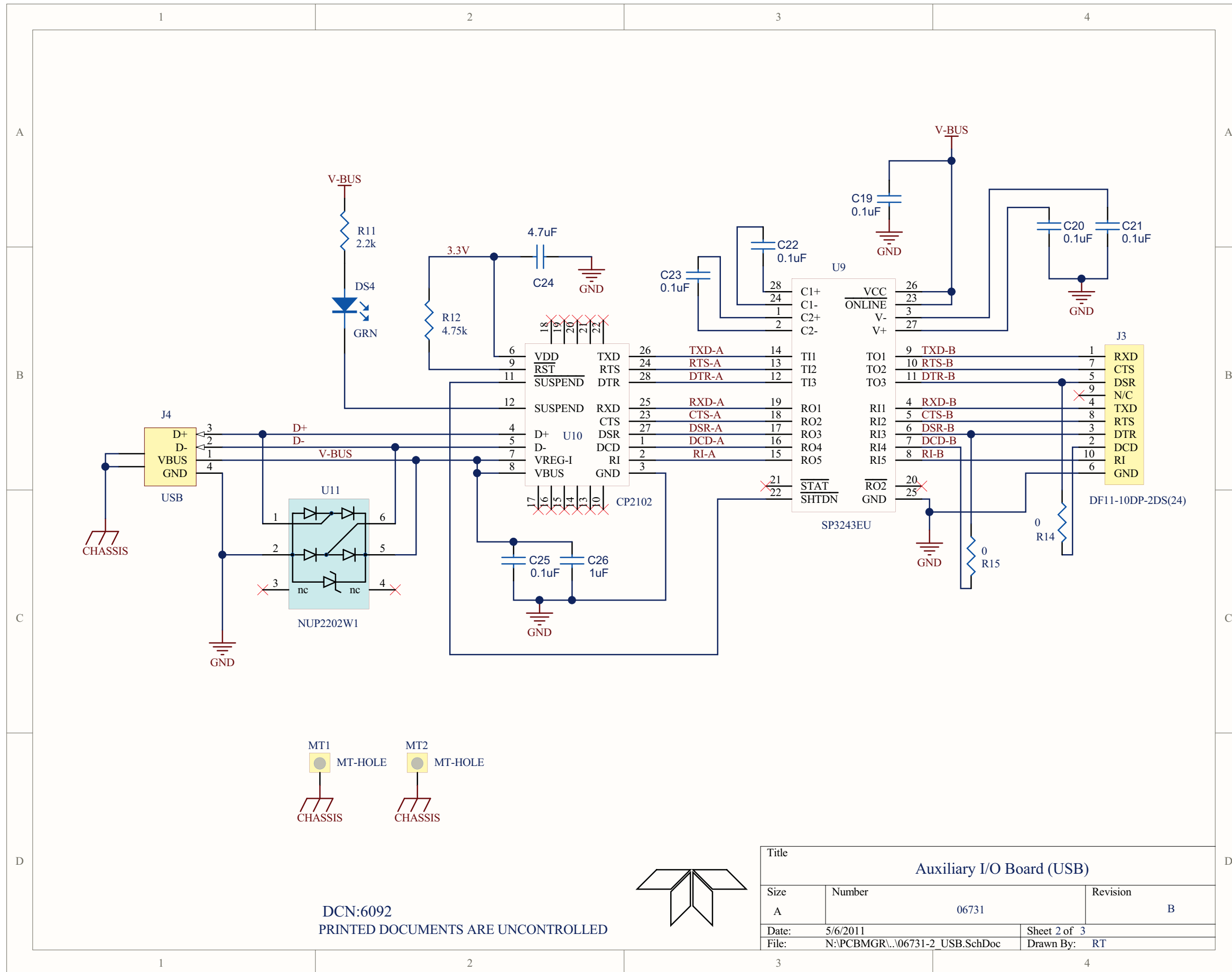

DCN:6092
 PRINTED DOCUMENTS ARE UNCONTROLLED

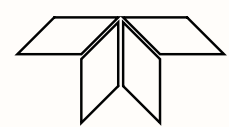

Title			Auxiliary I/O Board (USB)		
Size	Number	Revision			
A	06731	B			
Date:	5/6/2011	Sheet 2 of 3			
File:	N:\PCBMGR\...\06731-2 USB.SchDoc	Drawn By:		RT	

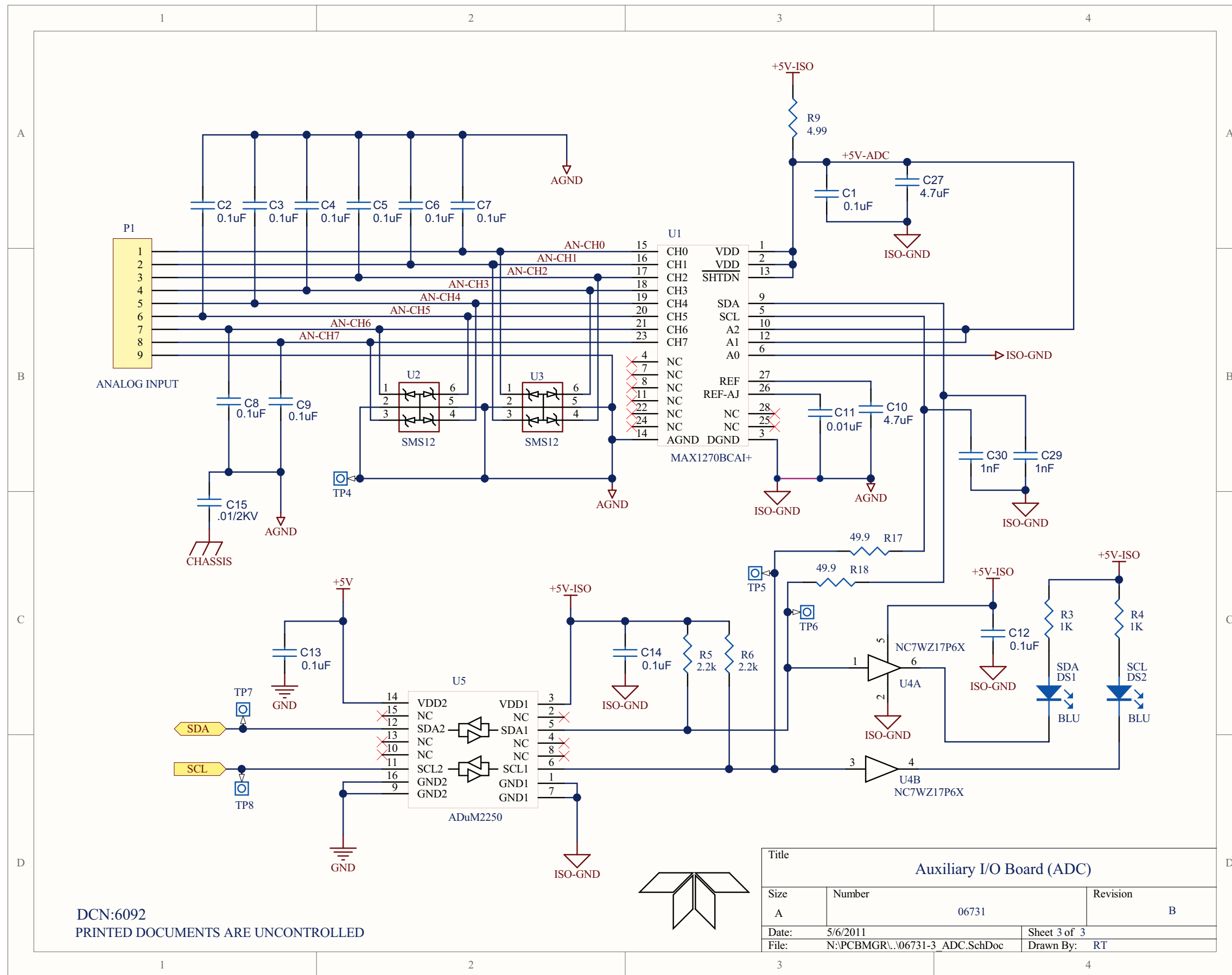

DCN:6092
PRINTED DOCUMENTS ARE UNCONTROLLED

Title		
Auxiliary I/O Board (ADC)		
Size	Number	Revision
A	06731	B
Date:	5/6/2011	Sheet 3 of 3
File:	N:\PCBMGR\...06731-3_ADC.SchDoc	Drawn By: RT