



TELEDYNE
ADVANCED POLLUTION INSTRUMENTATION
A Teledyne Technologies Company

ADDENDUM

MODEL T700U CALIBRATOR

(Addendum to the T700 Operation Manual, P/N 06873)

© TELEDYNE ADVANCED POLLUTION INSTRUMENTATION
(TELEDYNE-API)
9480 CARROLL PARK DRIVE
SAN DIEGO, CA 92121-5201

Toll-free Phone: 800-324-5190
Phone: 858-657-9800
Fax: 858-657-9816
Email: api-sales@teledyne.com
Website: <http://www.teledyne-api.com/>

SAFETY MESSAGES

Important safety messages are provided throughout this manual for the purpose of avoiding personal injury or instrument damage. Please read these messages carefully. Each safety message is associated with a safety alert symbol, and are placed throughout this manual and inside the instrument. The symbols with messages are defined as follows:



WARNING: Electrical Shock Hazard



HAZARD: Strong oxidizer



GENERAL WARNING/CAUTION: Read the accompanying message for specific information.



CAUTION: Hot Surface Warning



Do Not Touch: Touching some parts of the instrument without protection or proper tools could result in damage to the part(s) and/or the instrument.



Technician Symbol: All operations marked with this symbol are to be performed by qualified maintenance personnel only.



Electrical Ground: This symbol inside the instrument marks the central safety grounding point for the instrument.

CAUTION



This instrument should only be used for the purpose and in the manner described in this manual. If you use this instrument in a manner other than that for which it was intended, unpredictable behavior could ensue with possible hazardous consequences.

NEVER use any gas analyzer to sample combustible gas(es).

Note

Technical Assistance regarding the use and maintenance of this instrument or any other Teledyne API product can be obtained by contacting Teledyne API's Customer Service Department:

Telephone: 800-324-5190

Email: api-customerservice@teledyne.com

or by accessing various service options on our website at <http://www.teledyne-api.com/>

This page intentionally left blank.

ABOUT THIS MANUAL

This manual is intended for use in conjunction with the Model T700 Dynamic Dilution Calibrator Operation Manual, part number 06873.

REVISION HISTORY

Date	Rev	DCN	Change Summary
2012 May 08	B	6403	Specifications and AUTO mode
2010 October 06	A	5858	Initial Release

This page intentionally left blank.

CONTENTS

SAFETY MESSAGES	III
CONTENTS	V
LIST OF FIGURES	V
1. OVERVIEW	7
2. SPECIFICATIONS	7
3. OPERATIONAL MODES	9
3.1. GPTPS (GPT Pre-Set)	9
3.1.1. GPTPS Frequency	10
3.2. GPTZ (GPT Zero).....	11
3.2.1. GPTZ vs. AUTO Generation Modes	11
3.2.2. GPT	11
4. GPT SETUP	11
4.1. Flow Setup.....	12
4.2. Example GPT sequence.....	13
5. TYPICAL NO_x ANALYZER RESPONSE	14
6. PNEUMATIC DIAGRAMS	15
7. REFERENCES	16

LIST OF FIGURES

Figure 1. NO _x Analyzer Typical Resonse to GPT Test Sequence	14
Figure 2. T700U Pneumatic Diagram, Base Configuration.....	15
Figure 3. T700U Pneumatic Diagram, with Dual Output and Three MFC Options.....	16

APPENDIX A – Reference to Menu Trees

APPENDIX B – Spare Parts List and Warranty Repair Questionnaire

APPENDIX C – Warranty Repair Questionnaire

This page intentionally left blank.

1. OVERVIEW

This addendum supplements the T700 Operation Manual, PN 06873, with details specific to the operation of the T700U calibrator. The T700U is a modified version of the T700 calibrator, equipped with a special ozone generator capable of producing stable ozone concentrations for Gas Phase Titration (GPT) calibrations and Ozone generation at much lower levels than the standard T700.

2. T700U SPECIFICATIONS

Table 2-1: Dilution System

Parameter	Specification
Flow Measurement Accuracy	± 1.0% full Scale
Repeatability of Flow Control	± 0.2% full Scale
Linearity of Flow Measurement	± 0.5% full Scale
Flow Range of Diluent Air	0 to 10 SLPM
Flow Range of Cylinder Gases	0 to 200 cc/min
Zero Air Required	10 SLPM @ 30 psi Optional: 20 SLPM @ 30 psi
CAL Gas Input Ports	4 (configurable)
Diluent Gas Input Ports	1

Table 2-2: NO₂ Generation (GPT modes)

Parameter	Specification
Minimum Output	20 ppb LPM
Minimum Concentration:	3 ppb
Precision	± 2.0% (with GPTPS)

Table 2-3: Ozone Generator Module

Parameter	Specification
Maximum Output	6 ppm LPM
Minimum Output	20 ppb LPM
Minimum Ozone Concentration	3ppb
Response Time	180 seconds to 98%
Optical Feedback	Standard

Table 2-4: UV Photometer Option

Parameter	Specification
Range	100 ppb to 10 ppm (selectable)
Precision	1.0 ppb
Linearity	1.0% of reading
Rise/Fall Time	<20 seconds (photometer response)
Response Time	180 seconds to 95% (system response)
Zero Drift	<1.0 ppb / 24 hours

Table 2-5: Electrical and Physical Specifications

Parameter	Specification
AC Power	85V-264V, 47Hz-63Hz
Analog Outputs	1 user configurable output
Analog Output Ranges (Test Channel)	10V, 5V, 1V, 0.1V (selectable)
Analog Output Resolution	1 part in 4096 of selected full-scale voltage (12 bit)
Standard I/O	1 Ethernet: 10/100Base-T 2 RS-232 (300 – 115,200 baud) 2 USB device ports 8 digital control outputs 12 digital control inputs 8 digital status outputs
Optional I/O	1 USB com port 1 RS485 Multidrop RS232
Operating Temperature Range	5-40°C
Humidity Range	0 - 95% RH, non-condensing
Operating Altitude	10,000 ft Maximum
Dimensions (H x W x D)	7" x 17" x 24" (178 mm x 432 mm x 609 mm)
Weight	31 lbs (14.06 kg); 39.2 lbs (17.78 kg) with optional photometer, GPT, and O ₃ generator

3. OPERATIONAL MODES

The new T700U ozone generator is designed to operate in two modes: a high range mode, which gives similar performance as a standard T700 ozone generator, and a low range, or “fractional” mode for producing low levels of ozone during a GPT calibration.

The low range mode is supported in the following T700U Generation modes:

- AUTO (when generating ozone)
- GPTPS
- GPT
- GPTZ (accessed from the GEN menu, see the T700 operator’s manual for more details.)

The selection of low range generator operation is made automatically by the T700U software, based on the O₃ concentration and total flow specified. For O₃ output < 500 PPB • LPM, the low range operation is invoked.

3.1. AUTO

The AUTO mode can be used to generate ozone as a calibration gas for performing calibrations and calibration checks on ambient ozone analyzers.

When generating very low levels of ozone, care must be taken to ensure that the concentration-flow product is kept above the 20 ppb*LPM minimum value. This value is the target concentration (in ppb) multiplied by the total flow value.

Example: To determine the minimum flow rate required to generate 3 ppb:

$$3 \text{ ppb} * X \text{ LPM} > 20 \text{ ppb} * \text{LPM}$$

Or

$$X \text{ LPM} > (20 \text{ ppb} * \text{LPM}) / (3 \text{ ppb}) = 6.7 \text{ LPM}$$

Therefore the flow rate should be a minimum of 6.7 LPM to generate 3 ppb.

These equations can be used to determine the minimum flow rate for any desired concentration.

3.2. GPTPS (GPT PRE-SET)

The GPTPS mode is used to fine-tune the ozone generator calibration to improve the accuracy of the O₃ concentration during a subsequent GPT. This function is only available if the optional O₃ photometer is installed in the instrument.

During a GPTPS calibration, the internal photometer is used to measure the O₃ output and the O₃ GEN DRIVE value is adjusted to achieve the specified O₃ concentration. Once the concentration has stabilized (as indicated by the ACTIVE led switching from a blinking state to a constant on state), the instrument will store the updated O₃ GEN DRIVE value for later use when performing an actual GPT.

The following parameters must be entered for GPTPS:

Parameter	Definition	Notes
NO Concentration (ppb)	NO concentration that will be used in subsequent GPT	During the GPTPS, there is no NO gas generated. Instead, zero air is allowed to flow through the cal gas MFC at the same flow-rate that will be used during the GPT.
O ₃ Concentration	O ₃ concentration target	
Total Flow	Total output flow rate for subsequent GPT	The Total Flow parameter is used to calculate the Diluent flow required as follows: Diluent flow = Total Flow – O ₃ Gen Flow – NO Cal Gas Flow

The parameters entered for the GPTPS should be identical to the parameters that will be entered for the GPT. If a multi-point GPT is to run, then a separate GPTPS should be run for each O₃ concentration point.

3.2.1. GPTPS FREQUENCY

The GPTPS is an optional function used to increase the accuracy of the O₃ concentrations during a GPT. The GPTPS function is not required to be performed before each GPT; however, doing so will provide the best O₃ accuracy possible. If somewhat less precision can be tolerated from one GPT calibration to the next, then the GPTPS function can be run less frequently. The operator will need to determine the appropriate frequency based on their requirements.

3.3. GPTZ (GPT ZERO)

The GPTZ mode is used for obtaining the baseline NO and NO_x readings for calculating the NO_x converter efficiency. These readings are referred to as [NO]_{orig} and [NO_x]_{orig}, respectively in the EPA calibration guidelines.^{(1), (2)}

During GPTZ, NO gas is generated in the same manner as a GPT calibration, except that the O₃ generator lamp is un-energized, thus producing no O₃. This allows accurate measurement of the baseline NO and NO_x readings from the instrument under test.

3.3.1. GPTZ VS. AUTO GENERATION MODES

It may appear that the GPTZ and AUTO Generation modes are performing the same function: generating NO cal gas at a specified concentration and flow rate. However, there is an important difference in the flow configuration of these two modes.

In GPTZ mode, the total flow includes flow from the (un-energized) O₃ generator. This flow is not directly measured by the calibrator. The O₃ generator flow is measured at the factory and programmed into the T700U and assumed to be constant thereafter. Since pressure and temperature changes between the factory cal and the customer's ambient conditions cannot be accounted for, there may be small discrepancies between the actual O₃ generator flow and the assumed flow that is used in the dilution calculations that the T700U performs. Since these small flow discrepancies are present in both the GPTZ and GPT modes, they do not affect the accuracy of the converter efficiency calculations.

For the best overall dilution accuracy, for span calibrations for instance, the AUTO mode should still be used.

3.3.2. GPT

The GPT mode is used for performing the actual NO + O₃ titration used to produce the NO₂ test gas. This mode allows for the measurement of the [NO]_{rem} and [NO_x]_{rem} readings referred to in the EPA calibration guidelines^{(1), (2)}.

4. GPT SETUP

Careful consideration must be given to the various parameters involved in the setup of a GPT calibration, such as total flow, NO flow, NO concentration, O₃ concentration and NO gas bottle concentration.

These guidelines assume that the user has already established the target O₃ and NO concentrations based on other criteria.

4.1. FLOW SETUP

The following requirements should be used for determining total flow:

- Instrument's Flow Demand

The number and flow rate requirements of the instruments sampling from the output of the calibrator. The flow demand of all instruments connected to the test manifold, even those not directly involved in the testing, must be taken into account. The minimum output flow rate should be calculated as the sum of all instrument demand flows plus 10% minimum excess. ⁽¹⁾

- Target O₃ Concentration

The output flow must be chosen to keep the O₃ generator output above the minimum specification of 20 PPB□LPM. The minimum flow rate (FT) can then be calculated using the following equation:

$$F_T \geq \frac{20 \text{ ppb} \cdot \text{LPM}}{O_3 \text{ Conc}}$$

- NO Flow Requirements

To achieve a reasonable response time during the GPT and to satisfy the EPA requirement^{(1) (2)} that the residence time in the GPT reaction chamber be less than two minutes, the NO flow rate should be **greater than 45 cc/min**. Therefore, larger dilution flows may be required to achieve low concentrations of NO. An appropriate NO gas bottle concentration must be used in order to achieve this flow rate.

4.2. EXAMPLE GPT SEQUENCE

The following example shows the steps performed for a typical GPT calibration using the T700U. Note that this example assumes that a zero and span calibration has already been performed on the NO_x analyzer per EPA guidelines ⁽¹⁾.

Gas Bottle: 1.0 PPM NO

Step	Generation Mode		Notes	Values Obtained for Converter Efficiency Calculations ⁽¹⁾
1	GEN-GTPS		Optional step. Used to increase the accuracy of the O ₃ concentration during GPT generation mode.	N/A
	NO Conc	10 PPB		
	O ₃ Conc	8 PPB		
	Total Flow	8 SLPM		
	Target NO Flow (calculated by T700U)	80 SCCM		
2	GEN-AUTO-ZERO		Optional step. Used to verify zero calibration of NO _x analyzer.	N/A
	Total Flow	8 SLPM		
3	GEN-AUTO-GPT		Produces NO ₂ test gas using GPT with the ozone generator ON. The O ₃ lamp drive value is used from the previous GTPS.	[NO] _{rem} , [NO _x] _{rem}
	NO Conc	10 PPB		
	O ₃ Conc	8 PPB		
	Total Flow	8 SLPM		
	Target NO Flow (calculated by T700U)	80 SCCM		
4	GEN-AUTO-GPTZ		Delivers NO gas only for determining baseline (“orig”) NO and NO _x values. Ozone generator is OFF.	[NO] _{orig} , [NO _x] _{orig}
	NO Conc	10 PPB		
	O ₃ Conc	8 PPB		
	Total Flow	8 SLPM		
	Target NO Flow (calculated by T700U)	80 SCCM		

5. TYPICAL NO_x ANALYZER RESPONSE

The chart below shows the typical response of a low level NO_x analyzer, such as a T200U, when subjected to the GPT sequence described above.

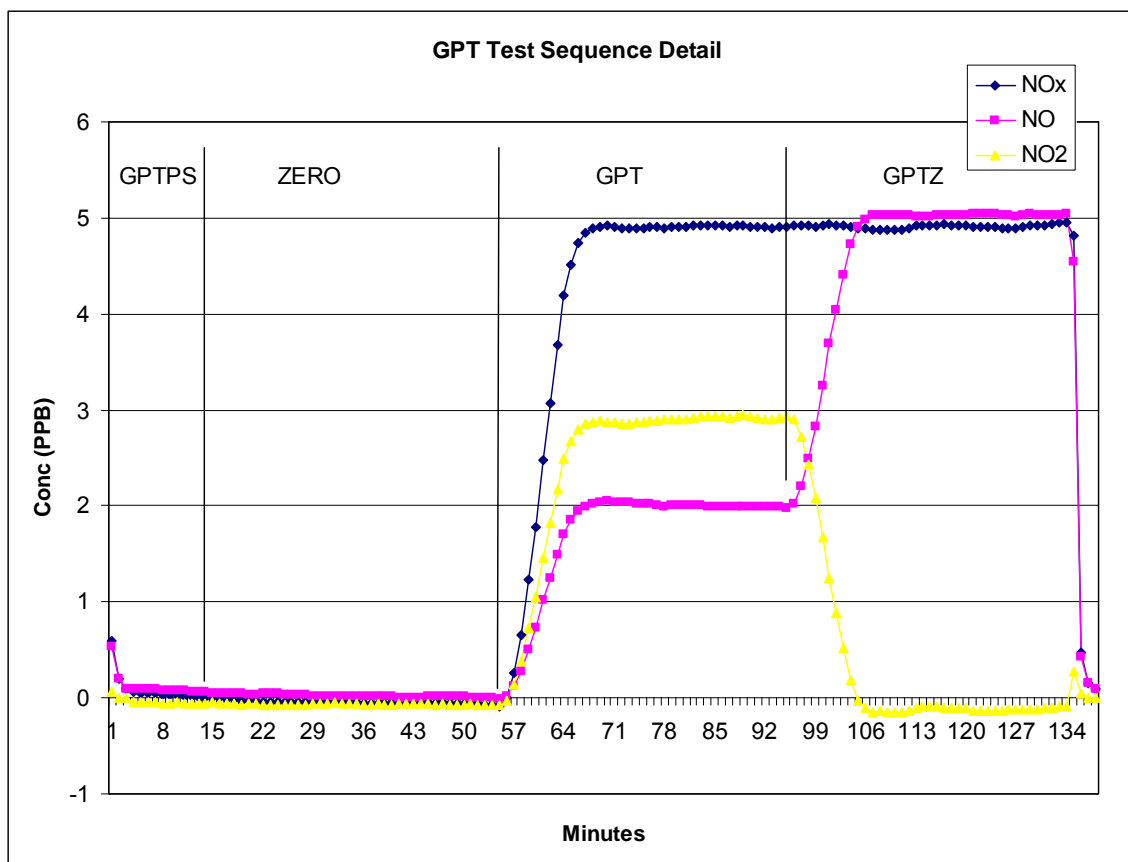

Figure 1. NO_x Analyzer Typical Response to GPT Test Sequence

6. PNEUMATIC DIAGRAMS

The pneumatic diagrams shown below can be used as an aid for troubleshooting.

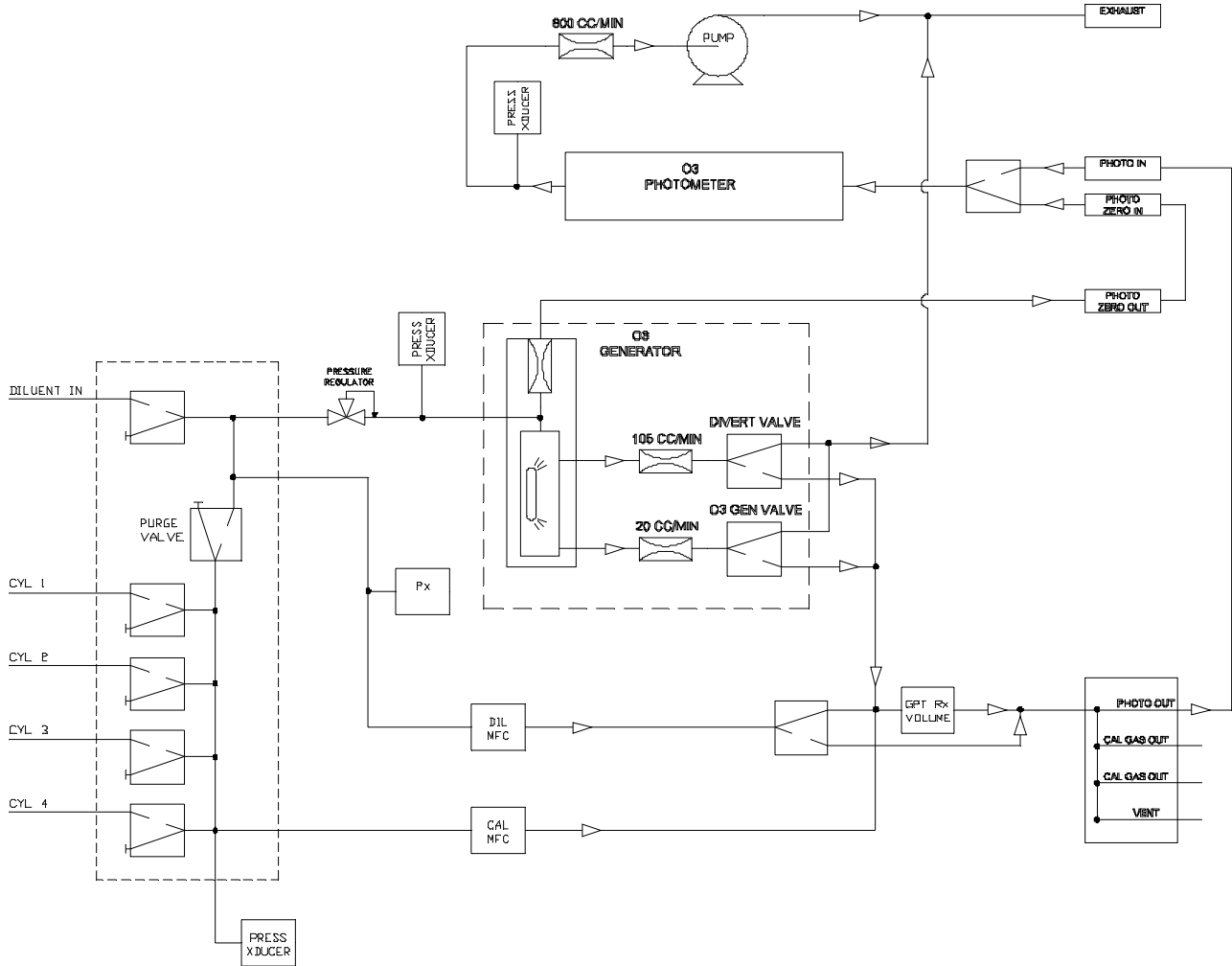

Figure 2. T700U Pneumatic Diagram, Base Configuration

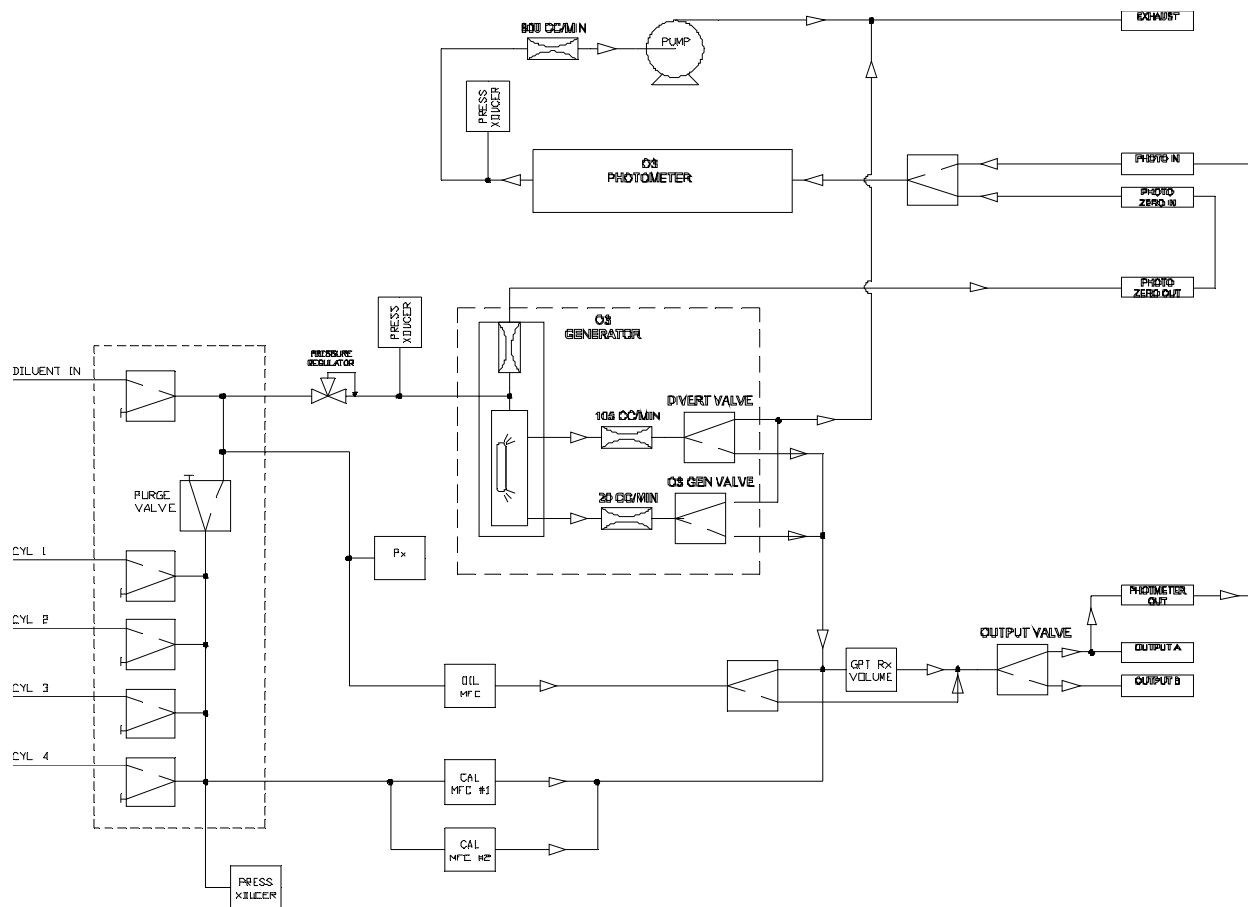

Figure 3. T700U Pneumatic Diagram, with Dual Output and Three MFC Options

7. REFERENCES

1. 40 CFR part 50 Appendix F, "Measurement Principle and Calibration Procedure for the Measurement of Nitrogen Dioxide in the Atmosphere (Gas Phase Chemiluminescence)"
2. E. C. Ellis, "Technical Assistance Document for the Chemiluminescence Measurement of Nitrogen Dioxide," EPA-E600/4-75-003, Environmental Monitoring and Support Laboratory, Research Triangle Park, NC 27711.

APPENDIX 5 - A Ybi 'HfYYg

D`YUgYfYZf'lc'5 ddYbXjl '5 'cZH YH+\$\$'a Ubi U"

This page intentionally left blank.

APPENDIX B - Spare Parts

Note Use of replacement parts other than those supplied by T-API may result in non compliance with European standard EN 61010-1.

Note Due to the dynamic nature of part numbers, please refer to the Website or call Customer Service for more recent updates to part numbers.

This page intentionally left blank.

T700U Spare Parts List
 PN06853B DCN6014 03/10/2011
 1 of 3 page(s)

Part Number	Description
000940100	ORIFICE, 3 MIL, O3 GEN
003290000	THERMISTOR, BASIC (VENDOR ASSY)(KB)
006120100	ASSY, UV LAMP, OZONE GENERATOR
014540300	CONTROLLER, MFC, HFC-212, 100SCCM *
014550300	CONTROLLER, MFC, HFC-212, 10 SLM *
014570100	ASSY, INLET MANIFOLD, (KB)
014900000	ASSY, GPT
016590100	ASSY, GPT VALVE
022710000	ABSORPTION TUBE, QUARTZ, (KB)
024710000	ASSY, TUBING, CLEAR FEP 1/8" (TU1), 6FT
024720000	ASSY, TUBING, (B/F) TU0000002, 6FT
024730000	ASSY, TUBING, TU0000005, 6FT
024750000	ASSY, TYGON TUBING (B/F) TU0000009, 6FT
040010000	ASSY, FAN REAR PANEL
040030500	PCA, PRESS SENSORS (2X)
040030600	PCA, PRESS SENSORS (1X), OZONE OPT
041200000	PCA, DET PREAMP w/OP20
041200200	PCA, DET PREAMP w/OP20
041240001	MANIFOLD, DETECTOR, (KB)
041270000	LAMP BLOCK, (KB)
041280000	LAMP SPACER, (KB)
041300000	EXHAUST MANIFOLD, (KB)
041440000	PCA, DC HEATER/TEMP SENSOR, OPTICAL BENCH
041660100	PCA, UV LAMP P/S, O3 GEN, *
042010000	ASSY, SAMPLE THERMISTOR
045230100	PCA, RELAY CARD
046740000	ASSY, PUMP, 12VDC (OP63)
048190300	ASSY, RELAY/PS, CAL
049290000	CLIP, THERMISTOR HOLDER
050490000	ASSY, O3 GENERATOR W/BRKT & REG
050500000	ASSY, O3 GENERATOR, 5LPM
052400000	ASSY, BENCH UV LAMP, (BIR), CR *
052910200	ASSY, OPTICAL BENCH, CAL
054690000	PCA, VALVE DRIVER, M700E
055020000	ASSY, INLET MANIFOLD W/PCA
055210000	OPTION, PHOTOMETER
055220000	ASSY, VALVE, PHOTOMETER
055240000	OPTION, OZONE, CAL (KB)
055270000	ASSY, EXHAUST MANIFOLD, (KB)
055560000	ASSY, VALVE, VA59 W/DIODE, 5" LEADS
056440000	ASSY, VALVE (VA23)
056450000	ASSY, VALVE (VA32)
056970000	PCA, EXT O/P ADPTR, LDS, (OPT)
057230000	PCA, SINGLE VALVE DRIVER (OPTION)

T700U Spare Parts List
 PN06853B DCN6014 03/10/2011
 2 of 3 page(s)

Part Number	Description
057360000	ASSY, 3/8" VENT ADAPTER
057400001	FRONT FERRULE,SS,1/4",SILCOSTEEL
057520001	FRONT FERRULE,SS, 1/8",SILCOSTEEL
057630000	ASSY, DUAL OUTPUT VALVE
058021400	PCA, E-SERIES MTHRBRD, M700E, GEN 5-I (ACCEPTS ACROSSER OR ICOP CPU)
058430001	FT 40 FITTING BODY, SILCOSTEEL COATED
058440001	FT 36 FITTING BODY, SILCOSTEEL COATED
060340001	FT 85 FITTING BODY, SILCOSTEEL COATED
061630000	ASSY, FILTER, DFU, DESORBER (SOAKED)
063110000	PCA, DC HEATER/THERM, 100W
064130000	ASSY, DC HEATER/THERM PCA, O3 GEN
066970000	PCA, INTRF. LCD TOUCH SCRIN, F/P
067240000	CPU, PC-104, VSX-6154E, ICOP *(KB)
067300000	PCA, AUX-I/O BD, ETHERNET, ANALOG & USB
067300100	PCA, AUX-I/O BOARD, ETHERNET
067300200	PCA, AUX-I/O BOARD, ETHERNET & USB
067900000	LCD MODULE, W/TOUCHSCREEN(KB)
068300100	DOM, w/SOFTWARE, STD, T700U *
068810000	PCA, LVDS TRANSMITTER BOARD
069500000	PCA, SERIAL & VIDEO INTERFACE BOARD
072150000	ASSY. TOUCHSCREEN CONTROL MODULE
072860000	KIT, T700U MANUAL
CN0000073	POWER ENTRY, 120/60 (KB)
CN0000458	CONNECTOR, REAR PANEL, 12 PIN
CN0000520	CONNECTOR, REAR PANEL, 10 PIN
CN0000640	CONNECTOR, REAR PANEL, 14 PIN
FM0000004	FLOWMETER (KB)
FM0000007	REGULATOR, PRESSURE, 0-30PSI(KB)
FT0000013	CONNECTOR-M, T, 1/8" (KB)
FT0000036	TEE-TTT, SS, 1/4" (HK)
FT0000040	UNION, BULKHEAD, SS, 1/4" (HK)
FT0000056	TEE-TTT, SS, 1/8" (HK)
FT0000085	PORT CONNECTOR, SS, 1/4" (HK)
FT0000134	BLKHD, UNION, REDUCING, SS, 1/4-1/8 (HK)
FT0000151	UNION, CROSS, TFE, 2-1/4", 2-1/8" KB
FT0000192	ELBOW, B, 1/8 X 1/4 TUBING
FT0000278	FEMALE COUPLING, 10-32, BRASS
FT0000279	HEX EXTENSION, B, 10-32 M-F
FT0000321	PORT CONNECTOR, SS, 1/8" (HK)
FT0000332	FITTING, 9 MIL, ZERO AIR FLOW
FT0000364	.003 ORIFICE, 10-32 X 10-32 W/ORING, BRA
FT0000429	ORIFICE, BARB, SS, 0.012"
HW0000005	FOOT
HW0000120	SHOCKMOUNT, GROMMET ISOLATOR
HW0000149	SEALING WASHER, #10
HW0000327	HEATSINK CLIP, TO-220

T700U Spare Parts List
 PN06853B DCN6014 03/10/2011
 3 of 3 page(s)

Part Number	Description
HW0000328	INSULATING THERMAL PAD, TO-220
HW0000356	PAD, THERMAL, TO-220, W/ ADHV
HW0000453	SUPPORT, CIRCUIT BD, 3/16" ICOP
KIT000253	ASSY & TEST, SPARE PS37
KIT000289	AKIT, UV LAMP P/S PCA, 041660100
KIT000290	AKIT, UV LAMP P/S PCA, 041660500
OP0000014	LAMP WINDOW, OPTICAL BENCH
OP0000031	WINDOW, OPTICAL BENCH & OZONE GEN FEEDBACK
OR0000001	ORING, SAMPLE FLOW & OZONE GENERATOR
OR0000013	ORING, 2-112V
OR0000026	ORING, ABSORPTION TUBE
OR0000039	ORING, OPTICAL BENCH & OZONE GEN FEEDBACK
OR0000046	ORING, 2-019V
OR0000048	ORING, OZONE GEN UV LAMP
OR0000077	ORING, 2-018V
OR0000089	ORING, OPTICAL BENCH
PS0000039	PS, SWITCHING, 12V/7.5A (KB)
PS0000040	PS,EXT,AC/DC (90-264V/47-63HZ),12V/3.75A
SW0000025	SWITCH, POWER, CIRC BREAK, VDE/CE *(KB)
WR0000008	POWER CORD, 10A(KB)

This page intentionally left blank.

Appendix C
Warranty/Repair Questionnaire
T700U, M700EU
(06878A, DCN6104)



CUSTOMER: _____ PHONE: _____

CONTACT NAME: _____ FAX NO. _____

SITE ADDRESS: _____

MODEL TYPE: _____ SERIAL NO.: _____ FIRMWARE REVISION: _____

Are there any failure messages? _____

PLEASE COMPLETE THE FOLLOWING TABLE (Depending on options installed, not all test parameters shown will be available in your calibrator):

PARAMETER	RECORDED VALUE	ACCEPTABLE VALUE
A-CAL	LPM*	TARG CAL \pm 1%
T-CAL	LPM*	0.001 – 0.100 SLPM
A-DIL	LPM*	TARG DIL \pm 1%
T-DIL	LPM*	0.01 – 10 SLPM
O3GEN FRAC		REFERENCE ONLY
O3GENREF ¹	mV	0 – 5000mV
O3FLOW ¹	LPM*	0.100 \pm 0.025 SLPM
O3GENDRV ¹	mV	0 – 5000mV
O3LAMPTMP ¹	$^{\circ}$ C	48 \pm 1 $^{\circ}$ C
CAL PRES	PSI	25 – 35PSI
DIL PRES	PSI	25 – 35PSI
REG PRES ¹	PSI	8 \pm 1PSI
(n/a)		TARG \pm 1%
A-GAS		T-GAS \pm 1%
T-GAS		
A-O3 ¹		T-O3 \pm 1%
T-O3 ¹		
(n/a)		
T-FLW	LPM*	
BOX TMP	$^{\circ}$ C	AMBIENT \pm 5 $^{\circ}$ C
PERM1 TMP ³	$^{\circ}$ C	50 \pm 1 $^{\circ}$ C
PERM FLW ³	LPM*	0.100 \pm 0.025 SLPM
PH MEAS ²	mV	2500 – 4800mV
PH REF ²	mV	2500 – 4800mV
PH FLW ²	LPM	0.720 – 0.880LPM
PH LTEMP ²	$^{\circ}$ C	58 \pm 1 $^{\circ}$ C
PH PRES ²	IN-HG	AMBIENT \pm 1 IN-HG
PH STEMP ²	$^{\circ}$ C	AMBIENT \pm 3 $^{\circ}$ C
PH SLOPE ²		0.85-1.15
PH OFFST ²	PPB	0 \pm 10 PPB

¹ If ozone generator option installed. ² If photometer option installed. ³ If permeation tube installed. *Standard flow

TELEDYNE API CUSTOMER SERVICE

Email: api-customerservice@teledyne.com

PHONE: (858) 657-9800 TOLL FREE: (800) 324-5190 FAX: (858) 657-9816

Appendix C
Warranty/Repair Questionnaire
T700U, M700EU
(06878A, DCN6104)



TELEDYNE
ADVANCED POLLUTION INSTRUMENTATION
A Teledyne Technologies Company

What is measured photometer flow rate _____ cc/min

What is measured O₃ generator flow rate? _____ cc/min

What is the pressure change during the **AUTO LEAK CHECK** procedure? _____ psi

What are the failure symptoms? _____

What tests have you done trying to solve the problem? _____

Thank you for providing this information. Your assistance enables Teledyne Instruments to respond faster to the problem that you are encountering.

OTHER NOTES: _____

TELEDYNE API CUSTOMER SERVICE
Email: api-customerservice@teledyne.com
PHONE: (858) 657-9800 TOLL FREE: (800) 324-5190 FAX: (858) 657-9816